



**Gabbioneta Pumps™**  
Heavy Duty Process Pumps  
**DSA Range**

## General information

The DSA range heavy duty process pumps are horizontal, between bearings with radial split casing and double suction impeller designed for full compliance with latest edition of API 610 Standard.

A wide range of sizes and material combination complete the variety of the offered products.

## Main design features:

- Geometry of pump components optimised through hydraulic, structural, thermal and dynamic F.E.M. analysis to guarantee high product reliability.
- Ample balancing line from 2nd. stage to suction maintain stuffing box pressures within limits easily acceptable by any type of balanced mechanical seals.
- Centreline casing mounting for high temperature stability
- Rotor operates far from its critical speeds
- Deep stuffing boxes integrally cast with pump casing, in accordance to API 682 Std., suitable to accept any type of mechanical or packing seals
- Labyrinths and deflectors at both bearing housing covers to maximise protection against dirt
- Suction and discharge nozzles, integrally cast with the casing, are arranged in in-line position
- Three bearings arrangements available:
  - Ball Radial / Ball Thrust
  - Sleeve Radial / Ball Thrust
  - Sleeve Radial / Tilting Pads Thrust (Kingsbury Type).

## Options

The following pump designs can be provided:

- For extremely low NPSH duties, a number of DSA pumps can be equipped with inducers
- Steam jacketed casing for special applications
- Replaceable stuffing box cooling or heating jackets
- Double shaft extension
- Cylindrical fit at coupling shaft end
- Special bearing isolators at either bearing housing ends
- 'CARB' or hydrodynamic line bearing for high temperature application
- Oil mist lubrication system (pure or purge)
- Forced feed lubrication system
- Temperature and/or vibration detection and monitoring equipment
- Baseplate available with three point gimbals mounting (FP50 services)

## Main pumps applications refer to heavy duties on

- Oil & Gas
- Fluid transportation
- Refineries
- Petrochemical plants
- "Hot" charge

## Operating data

### Capacity

up to 7500 m<sup>3</sup>/h (33000 USgpm)

### Head

up to 380 m (1200 feet)

### Temperature

from - 30°C (-20°F) to 455°C (850°F)

### Design working pressure

up to 100 barg (1400 psig)

### Rotational speed

up to 3800 rpm

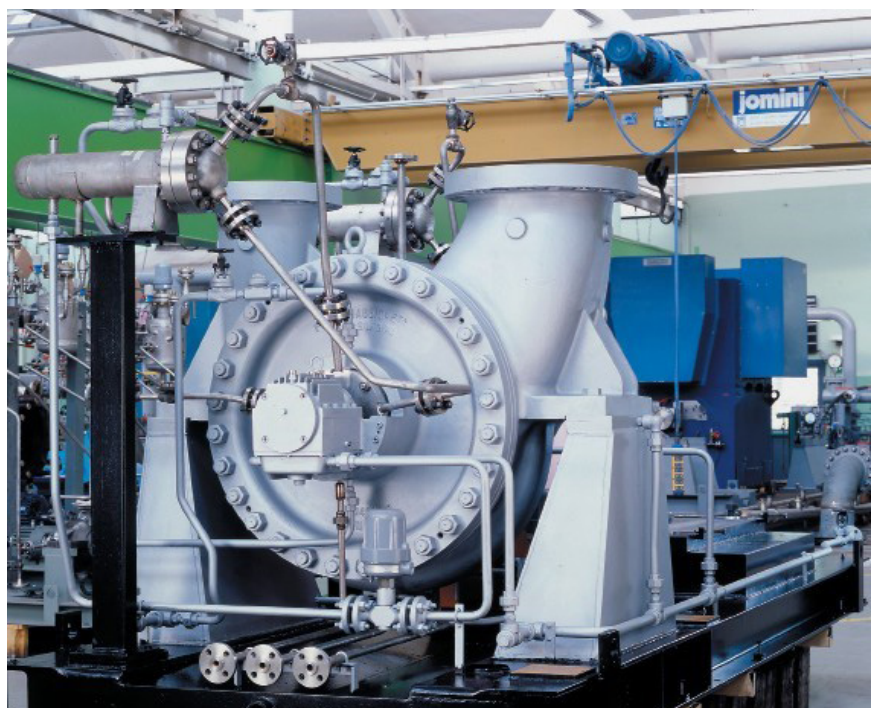

# Coverage Chart

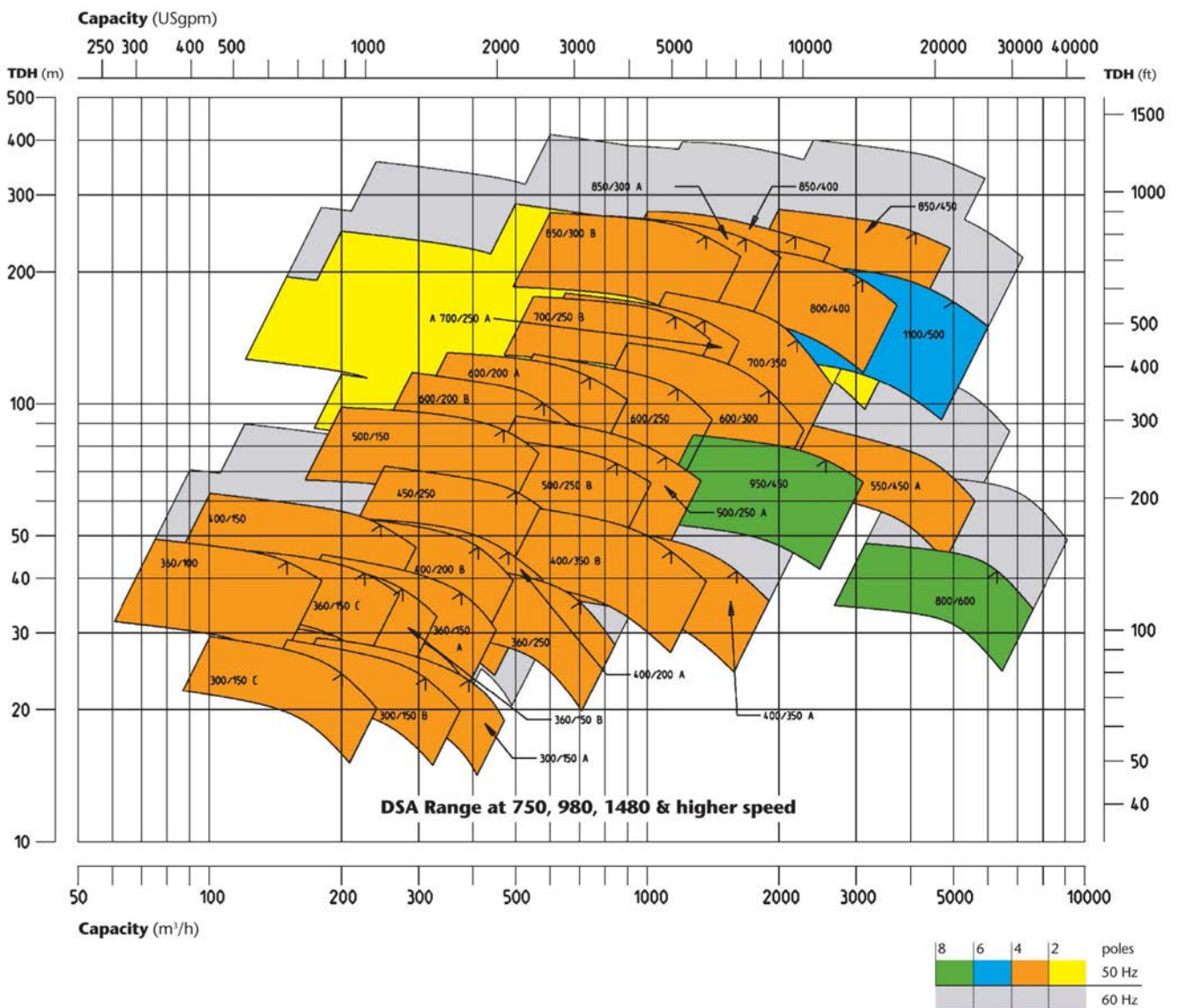

### Pump identification

Pump type DSA 450 / 250

Nominal impeller diameter (mm) |

Nominal discharge nozzle diameter (mm) |

A

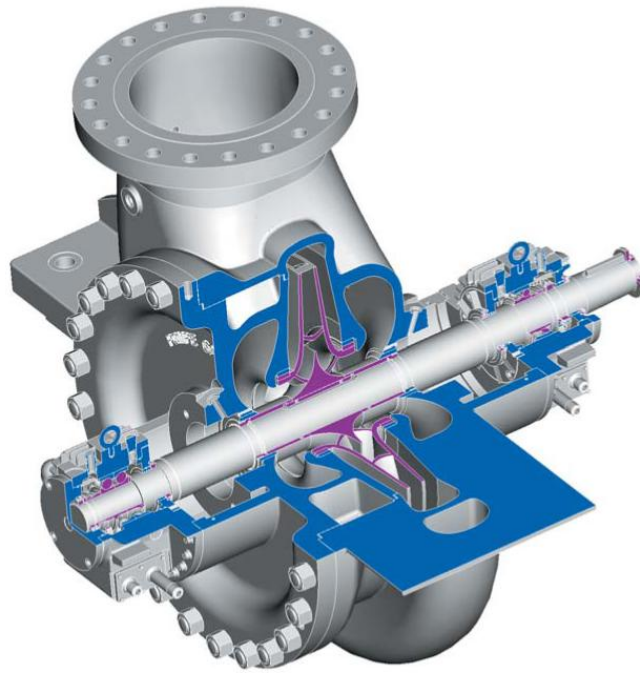

B

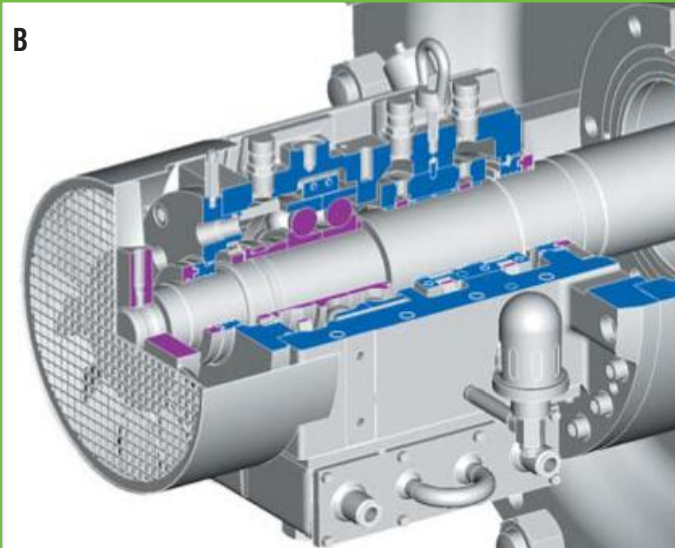

C

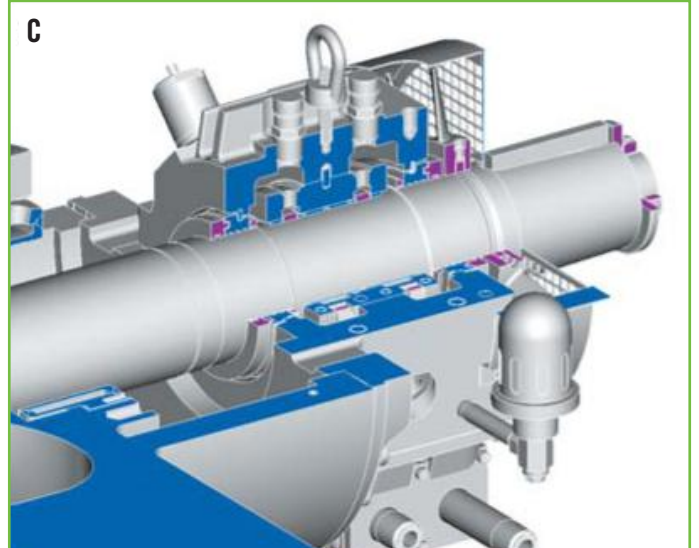

D

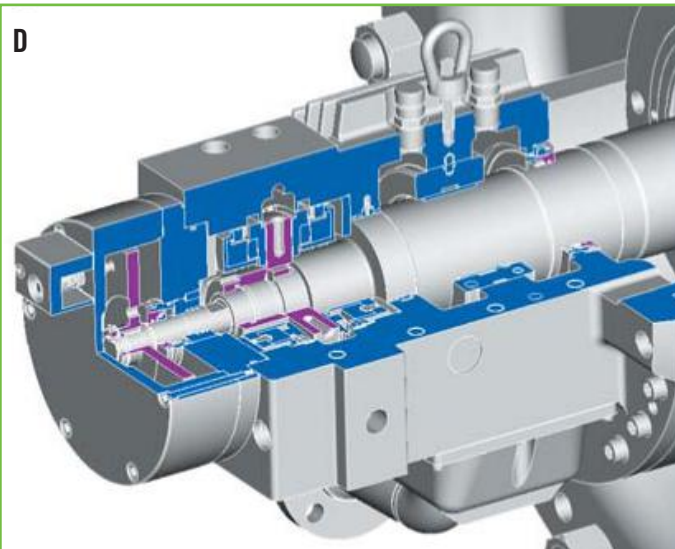

E

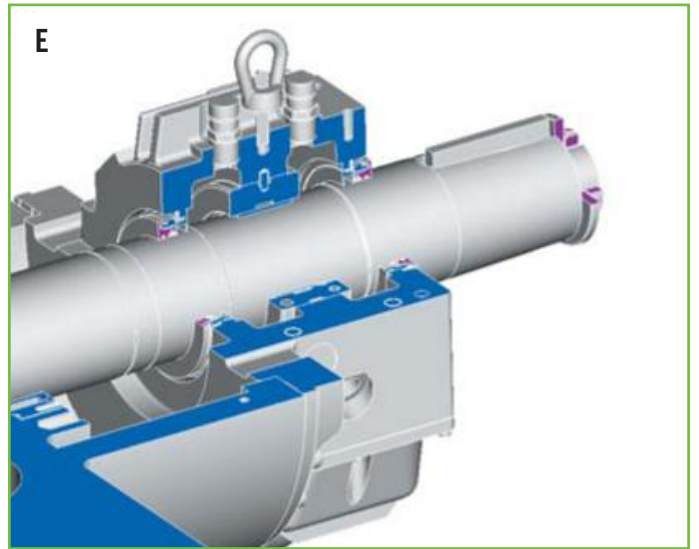

- A. Ball-Ball
- B. Sleeve-Ball NDE
- C. Sleeve-Ball DE
- D. Sleeve-Kingsbury NDE
- E. Sleeve-Kingsbury DE

## Overall dimensions

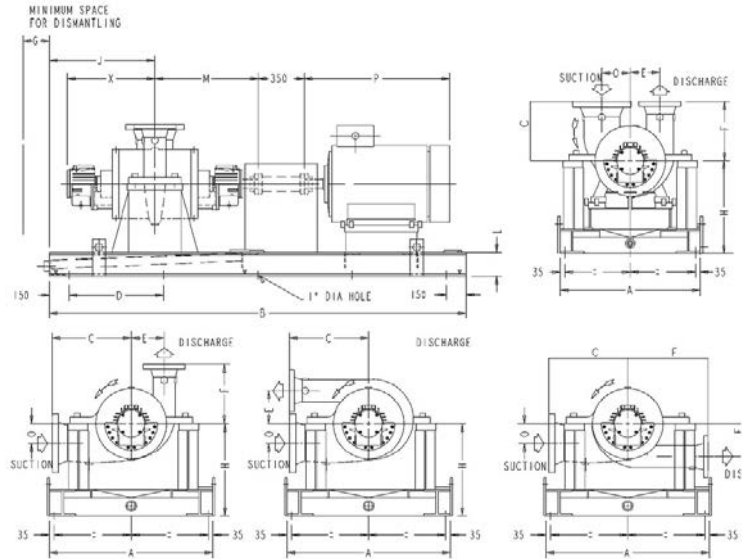

### General notes

1. All dimensions are in mm. Do not use for construction unless certified.
2. TT, ST, SS respectively means top-top, side-top, side-side
3. Dimensions B and P vary with driver selection.
4. Dimension X relative to Sleeve-Kingsbury configuration does not include the coaxial lube oil pump.

PUMP TYPE	NOZZLE SIZE		A	C	D	E	F	G	H	X			O	M	J	L
	Suct.	Disch.								B/B	S/B	S/K				
300/150TT	10"	6"	1240	450	715	225	450	1100	700	664	882	861	215	825	800	200
300/200TT	12"	8"	1390	450	715	250	450	1100	700	644	862	841	300	805	800	200
360/100 ST	8"	4"	1240	550	715	240	400	1100	700	598	816	795	150	745	1000	200
360/100 TT	8"	4"	1240	400	715	240	400	1100	700	598	816	795	225	745	800	200
360/150 ST	10"	6"	1240	600	715	250	450	1100	700	704	922	901	150	865	850	200
360/150 TT	10"	6"	1240	450	715	250	540	1100	700	704	922	901	220	865	800	200
360/250 TT	14"	10"	1545	520	715	300	520	1100	800	718	936	915	300	885	850	200
400/150 TT	10"	6"	1240	500	715	255	500	1100	700	647	865	844	220	810	800	200
400/200 SS	12"	8"	1390	650	715	270	-	1100	800	604	822	801	300	785	850	200
400/200 TT	12"	8"	1390	500	715	270	500	1100	800	604	822	801	300	785	850	200
400/200 ST	12"	8"	1390	650	715	270	500	1100	800	604	822	801	150	785	850	200
400/350 TT	18"	14"	1700	700	715	400	700	1400	800	720	937	916	400	900	1000	200
450/250 ST	14"	10"	1545	730	715	300	550	1100	800	679	897	876	0	860	850	200
450/250 TT	14"	10"	1545	550	715	300	550	1100	800	679	897	876	400	860	800	200
500/150 TT	10"	6"	1390	550	715	330	550	1100	800	644	862	841	280	790	850	200
500/150 SS	10"	6"	1390	750	715	330	-	1100	800	644	862	841	280	790	850	200
500/250 TT	14"	10"	1700	600	715	370	600	1100	900	671	889	868	320	835	800	200
550/450 TT	24"	18"	2400	950	715	550	950	1600	1100	853	1071	1050	500	1015	1100	240
600/200 TT	12"	8"	1700	600	715	400	600	1100	900	644	862	841	320	810	800	200
600/200 ST	12"	8"	1900	850	715	400	600	1100	900	644	862	841	320	810	800	200
600/250 TT	14"	10"	1700	650	715	400	650	1100	900	671	889	868	300	835	800	200
600/250 SS	14"	10"	1700	850	715	400	-	1100	900	671	889	868	300	835	800	200
600/300 ST	14"	12"	1900	850	715	400	750	1100	900	758	976	955	300	925	1000	200
600/300 TT	14"	12"	1900	750	715	400	750	1100	900	758	976	955	400	925	1000	200
700/250 ST	14"	10"	1900	900	715	455	650	1100	900	633	851	830	0	800	850	200
700/250 TT	14"	10"	1900	650	715	455	650	1100	900	633	851	830	300	800	850	200
700/350 TT	18"	14"	2000	700	715	455	700	1400	1100	754	996	952	455	930	1300	240
700/350 IL	18"	14"	2000	850	715	475	850	1400	1200	754	96	982	420	930	1300	240
800/400 TT*	20"	16"	2000	800	715	520	800	1300	1100	858	1100	1086	520	1085	1050	240
800/600 TT*	32"	24"	2800	1000	715	700	1000	2000	1400	1063	1305	1291	725	1290	1500	300
850/300 TT*	16"	12"	1900	600	715	500	800	1300	1100	808	1050	1036	500	1035	1000	240
850/400 TT*	20"	16"	2000	800	715	520	800	1300	1100	858	1100	1086	520	1085	1050	240
850/450 IL*	24"	18"	2000	950	715	520	850	1500	1200	888	1030	1016	420	1115	1100	260
850/450 TT*	24"	18"	2400	800	715	570	800	1500	1100	888	1030	1016	500	1115	1300	260
950/450 TT*	24"	18"	3000	900	715	650	900	1500	1400	888	1030	1016	600	1115	1300	300
1100/500 TT*	26"	20"	3000	1000	715	750	1000	1800	1400	973	1215	1201	700	1200	1500	300

\* C.C.W rotation from coupling side

## A century of experience

Since the foundation of the company in 1897, Gabbioneta pumps™ has been engaged in design and manufacture of high quality centrifugal pumps.

The products and the markets served progressively changed from water to chemical industry and finally, in the last thirty years, to API 610 heavy duty pumps for refinery and petrochemical industries.

Product development is based on a thorough interchange of marketing and operating experience within the company and in close cooperation with project and plant engineers.

Manufacturing is carried out in a factory equipped with several modern CNC machines and machine tools. Special note has to be given to the machining centers where pump casings can be machined completely with only two settings.

In-house facilities are designed to meet the performance and NPSH testing requirements of all pumps manufactured in the company in full compliance with API 610 Standards.

A quality assurance system certified in accordance with ISO 9001 ensures Gabbioneta pumps™ are of the highest quality.





**Trillium Pumps Italy S.r.l.**  
**Società Unipersonale**

Gaetana Agnesi 1, 20834 Nova Milanese (MB), Italy  
T: +39 0362 17331; Fax: +39 0362 1733209; E: [gabbioneta.sales@trilliumflow.com](mailto:gabbioneta.sales@trilliumflow.com)

[www.trilliumflow.com](http://www.trilliumflow.com) Certified: ISO 9001:2015, ISO 14001:2015, OHSAS 18001:2007