

NOTE: WHEN USING OPTIONAL REMOVABLE COUPLING ADD 3" TO HEIGHT OF MIXERS. (DIMENSIONS "A" OR "B".)

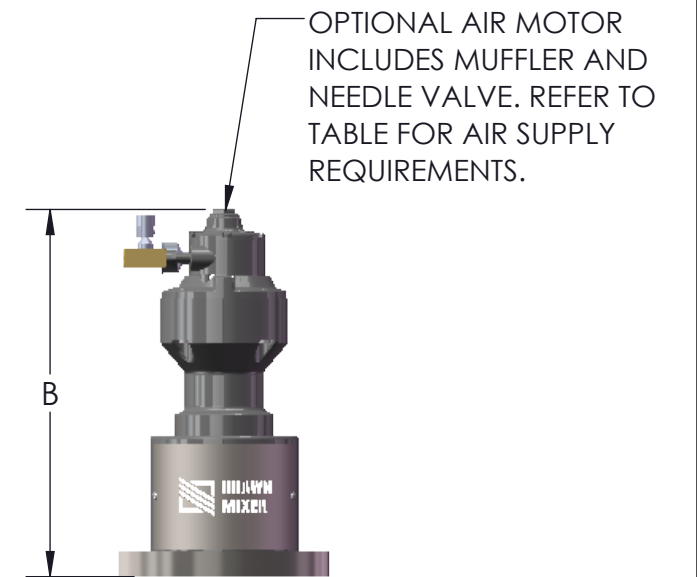
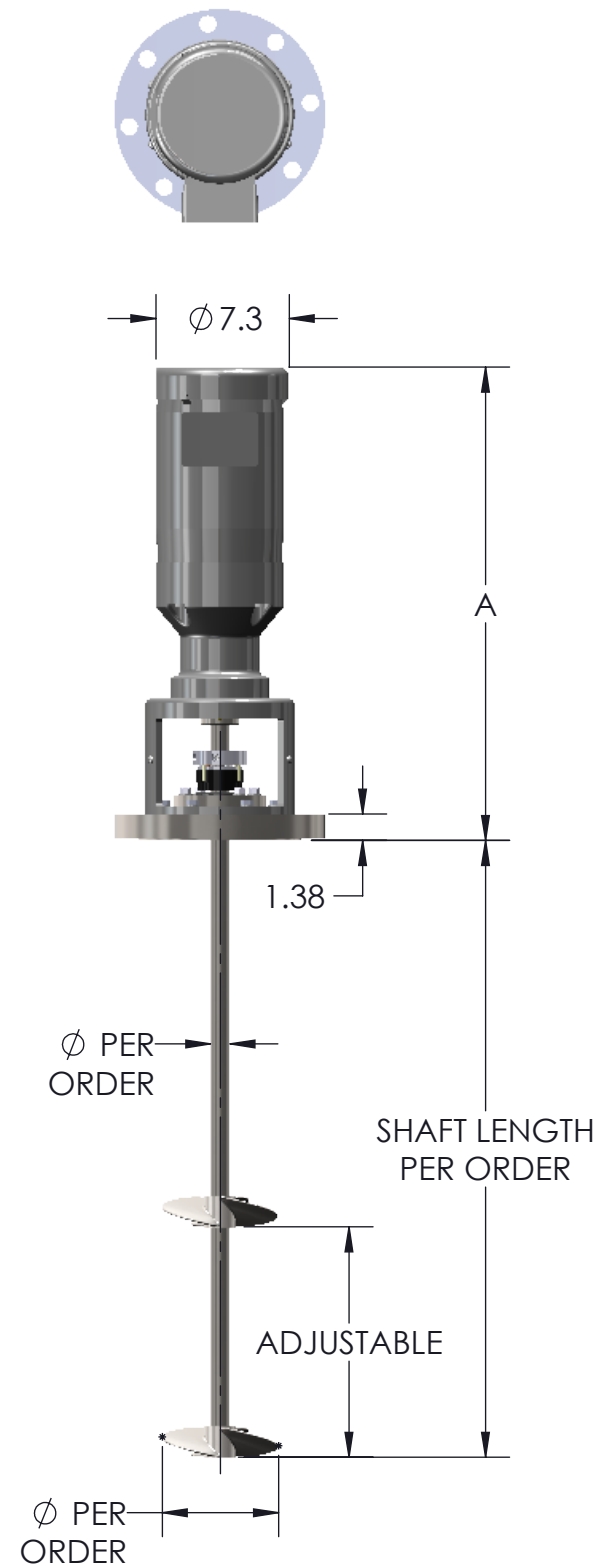

ALL DIMENSIONS ARE IN INCHES.

MIXER MODEL	DIMENSION		
	A	B	*WGT
BDF33	24.8	18.9	71
BDF50	24.8	18.9	73
BDF75	24.8	19.5	76
BDF100	25.7	19.5	81
BDF150	25.7	19.5	85
BDF200	36.7	20.9	92
BDF300	27.6	20.9	100
BDF500	29.9	24.0	126

AIR MOTOR HORSEPOWER AND AIR CONSUMPTION				
HORSEPOWER	1/2	1	2	3
CFM AIR CONSUMPTION	23	40	70	100
AT PSI	40	80	70	70
INLET SIZE (NPT)	3/8	3/8	1/2	1/2

\*WEIGHT IS IN POUNDS WITH ELECTRIC MOTOR. DOES NOT INCLUDE SHAFT OR IMPELLER(S) OR AIR MOTOR.

\*FOR REFERENCE ONLY\*

\* ALL DIMENSIONS AND WEIGHTS ARE FOR REFERENCE ONLY UNLESS THE DRAWING IS CERTIFIED.

\* ALL EQUIPMENT DESIGN AND APPLICATION DATA SHOWN HEREIN IS CONFIDENTIAL AND THE PROPERTY OF BRAUN MIXER. NO USE OR DISCLOSURE THEREOF MAY BE MADE WITHOUT OUR WRITTEN PERMISSION.

DRAWN BY:BSB DATE:9/5/2018 © 2018

APPROVED BY: DATE:



12838 STAINLESS DR HOLLAND, MI 49424

PH: 616-399-5600 FAX: 616-399-3084

MIXER MODEL BDF33 THRU 500 WITH MECHANICAL SEAL DIMENSION AND ASSEMBLY DRAWING

DWG. NO. B- TK0011 REV.