

DME Variant B (60-940 l/h)

Installation and operating instructions

US F E



LIMITED WARRANTY

Products manufactured by GRUNDFOS PUMPS CORPORATION (Grundfos) are warranted to the original user only to be free of defects in material and workmanship for a period of 24 months from date of installation, but not more than 30 months from date of manufacture. Grundfos' liability under this warranty shall be limited to repairing or replacing at Grundfos' option, without charge, F.O.B. Grundfos' factory or authorized service station, any product of Grundfos' manufacture. Grundfos will not be liable for any costs of removal, installation, transportation, or any other charges which may arise in connection with a warranty claim. Products which are sold but not manufactured by Grundfos are subject to the warranty provided by the manufacturer of said products and not by Grundfos' warranty. Grundfos will not be liable for damage or wear to products caused by abnormal operating conditions, accident, abuse, misuse, unauthorized alteration or repair, or if the product was not installed in accordance with Grundfos' printed installation and operating instructions.

To obtain service under this warranty, the defective product must be returned to the distributor or dealer of Grundfos' products from which it was purchased together with proof of purchase and installation date, failure date, and supporting installation data. Unless otherwise provided, the distributor or dealer will contact Grundfos or an authorized service station for instructions. Any defective product to be returned to Grundfos or a service station must be sent freight prepaid; documentation supporting the warranty claim and/or a Return Material Authorization must be included if so instructed.

GRUNDFOS WILL NOT BE LIABLE FOR ANY INCIDENTAL OR CONSEQUENTIAL DAMAGES, LOSSES, OR EXPENSES ARISING FROM INSTALLATION, USE, OR ANY OTHER CAUSES. THERE ARE NO EXPRESS OR IMPLIED WARRANTIES, INCLUDING MERCHANTABILITY OR FITNESS FOR A PARTICULAR PURPOSE, WHICH EXTEND BEYOND THOSE WARRANTIES DESCRIBED OR REFERRED TO ABOVE.

Some jurisdictions do not allow the exclusion or limitation of incidental or consequential damages and some jurisdictions do not allow limit actions on how long implied warranties may last. Therefore, the above limitations or exclusions may not apply to you. This warranty gives you specific legal rights and you may also have other rights which vary from jurisdiction to jurisdiction.

DME Variant B (60-940 l/h)

Installation and operating instructions

4 **US**

Notice d'installation et d'entretien

23 **F**

Instrucciones de instalación y funcionamiento

43 **E**

CONTENTS

1. General description	4
1.1 Applications	4
1.2 Type key	5
2. Technical data	6
2.1 Mechanical data	6
2.2 Electrical data	6
2.3 Dimensions	6
3. Installation	7
3.1 Safety instructions	7
3.2 Installation environment	7
3.3 Installation of pump	7
3.4 Installation example	8
3.5 Electrical connection	8
4. Functions	9
4.1 Control panel	9
4.2 Start/stop of pump	10
4.3 Priming/venting of pump	10
4.4 Indicator lights	10
4.5 Menu	11
4.6 Manual	12
4.7 Anti-cavitation	12
4.8 Capacity limitation	13
4.9 Counters	13
4.10 Resetting	14
4.11 Return	14
4.12 Language	15
4.13 Alarm	15
4.14 Measuring units	16
4.15 Control panel lock	17
5. Start-up	18
6. Calibration	19
6.1 Direct calibration	20
6.2 Check calibration	21
7. Maintenance	21
8. Service	21
9. Fault finding chart	22
10. Disposal	22

1. General description

The Grundfos DME dosing pump is a self-priming diaphragm pump.

The pump consists of:

- a **cabinet** incorporating the drive unit and electronics,
- a **dosing head** with back plate, diaphragm, valves, connections and vent valve,
- a **control panel** incorporating display and buttons. The control panel is fitted either to the end or to the side of the cabinet.

The motor is controlled in such a way that the dosing gets as even and constant as possible, irrespective of the capacity range in which the pump is operating.

This is carried out as follows:

The speed of the suction stroke is kept constant and the stroke relatively short, irrespective of the capacity. Contrary to conventional pumps, which generate the dosing stroke as a short pulse, the duration of the dosing stroke will be as long as possible. Thus, an even dosing without peak values is ensured. As the pump is always dosing at full stroke length, it ensures the same high accuracy and suction capability, irrespective of the capacity, which is infinitely variable in the ratio of 1:800.

The pump features an LCD display and a user-friendly control panel which gives access to the pump functions.

1.1 Applications

The DME dosing pump is designed for handling chemicals within the following ranges of applications, among others:

- Drinking water treatment
- Wastewater treatment
- Cooling water treatment
- Washing systems
- Process water treatment
- Chemical industry.

WARNING!



Prior to installation, read these installation and operating instructions. Installation and operation must comply with local regulations and accepted codes of good practice.

This pump has been tested using water and following chemical types:

- hydrochloric acid (HCL) 30-40%
- sodium hydroxide (NaOH) 5-50%
- nitric acid (HNO₃) 5-65%
- hydrogen peroxide (H₂O₂) 5-30%
- sodium hypochlorite (NaClO) 20%
- sulphuric acid (H₂SO₄) 96%
- aluminium sulfate (Al₂SO₄)₃ in aqueous solutions,
- laundry detergent and
- ferric chloride (FeCl₃) in aqueous solutions.

CAUTION: The suitability of this pump for use with liquids other than water or the above chemicals is the responsibility of the end user.

1.2 Type key

(Cannot be used for pump configuration.)

Code	Example	DME	60	-	10	B	-	PP/	E/	C-	F-	2	1	A3	A3	B	
	Grundfos dosing pump																
	Maximum capacity [gph (l/h)]																
	15.9 (60)																
	39.6 (150)																
	99.1 (375)																
	248.3 (940)																
	Maximum pressure [psi (bar)]																
	145 (10)																
	58 (4)																
	145 (10)																
	58 (4)																
	Control variant																
B	Basic																
	Dosing head material																
PP	Polypropylene																
PV	PVDF																
SS	316 stainless steel																
	Gasket material																
E	EPDM																
V	FKM																
	Valve ball material																
C	Ceramics																
G	Glass																
SS	316 stainless steel																
Y	Hastelloy® C - 22																
	Control panel																
F	Front-fitted																
S	Side-fitted																
	Voltage																
2	120 V, 60 Hz																
	Valves																
1	Standard valve																
2	Spring-loaded valve																
	Connection, suction																
A3	3/4" FNPT																
A4	1 1/4" FNPT																
	Connection, discharge																
A3	3/4" FNPT																
A4	1 1/4" FNPT																
	Mains plug																
B	US																

US

2. Technical data

2.1 Mechanical data

	DME 60	DME 150	DME 375	DME 940
Maximum capacity* ¹ [gph (l/h)]	15.9 (60)	39.6 (150)	99.1 (376)	248.3 (940)
Maximum capacity with anti-cavitation 75%* ¹ [gph (l/h)]	11.9 (45)	29.6 (112)	74.2 (281)	186.2 (705)
Maximum capacity with anti-cavitation 50%* ¹ [gph (l/h)]	7.9 (30)	19.8 (75)	49.7 (188)	124.2 (470)
Maximum capacity with anti-cavitation 25%* ¹ [gph (l/h)]	4.0 (15)	10.0 (38)	24.8 (94)	62.1 (235)
Maximum pressure [psi (bar)]	145 (10)	58 (4)	145 (10)	58 (4)
Maximum stroke rate per minute [strokes/min.]	160			
Maximum suction lift during operation [ft (m)]	13.1 (4)			
Maximum suction lift when priming with wet valves [ft (m)]	4.9 (1.5)			
Maximum viscosity with spring-loaded valves* ² [mPas]	3000 mPas at 50% capacity			
Maximum viscosity without spring-loaded valves* ² [mPas]	200			
Diaphragm diameter [mm]	79	106	124	173
Liquid temperature [°F (°C)]	122 (50)			
Ambient temperature [°F(°C)]	113 (45)			
Accuracy of repeatability	±1%			
Sound pressure level [dB(A)]	<70			

*¹ Irrespective of back pressure within the pump's specified range

*² Maximum suction lift 1 meter

2.2 Electrical data

	DME 60	DME 150	DME 375	DME 940
Supply voltage [VAC]	1 x 100-240			
Maximum current consumption [A]	at 100 V	1.2	2.4	
	at 230 V	0.6	1.0	
Maximum power consumption P ₁ [W]	61.33		240	
Frequency [Hz]	50-60			
Enclosure class	IP 65			
Insulation class	B			
Supply cable	1.5 m H05RN-F with plug			

2.3 Dimensions



See dimensions at the end of these instructions.

3. Installation

3.1 Safety instructions



WARNING!

- Liquid is under pressure and may be hazardous.
- When working with chemicals, local safety rules and regulations must be observed (e.g. wear protective clothes).
- Before starting work on the dosing pump and system, disconnect the electricity supply to the pump, ensuring that it cannot be accidentally switched on. Before reconnecting the electricity supply, make sure that the dosing hose is positioned in such a way that any chemical left in the dosing head is not ejected, thereby exposing persons to danger.
- If the vent valve in the dosing head is used, it must be connected to a hose which is led back to the tank.
- When changing a chemical, make sure that the materials of the dosing pump and system are resistant to the new chemical. If there is any risk of chemical reaction between the two types of chemicals, clean the pump and system thoroughly before adding the new chemical.
Proceed as follows:
Place the suction tube in water and press the  button until residual chemical has been removed.
NOTE: When the buttons  and  are pressed simultaneously, the pump can be set to run for a specific number of seconds at maximum capacity. The remaining number of seconds will appear in the display. The maximum value is 300 seconds.

3.2 Installation environment

- Exposure to direct sunlight should be avoided. This applies especially to pumps with plastic dosing heads, as this material can be damaged by sunlight.
- If the pump is installed outside, an enclosure or similar protection is required to protect the pump against rain and moisture.

3.3 Installation of pump

- See also the installation example in section 3.4.
- **CAUTION:** The dosing head may contain water from the factory test. If a liquid which must not come into contact with water is to be dosed, it is recommended to let the pump run with another liquid to remove the water from the dosing head before installation.
- Always install the pump on the supporting foot with vertical suction and discharge ports.
- Always use suitable tools for the mounting of plastic parts. Never apply unnecessary force.
- Make sure that the dosing pump and system are designed in such a way that neither system equipment nor buildings are damaged in case of leakage from the pump or rupture of hoses/pipes. The installation of leakage hoses and collecting tanks is recommended.
- Make sure that the drain hole in the dosing head points downwards, see fig. 1.
- Secure the pump to the surface.
- Make sure that there is free access to the plug during installation and operation.
CAUTION: It is important that the drain pipe/hole is not inserted direct into the tank contents, as gasses may penetrate into the pump.
- **NOTE:** Tighten the pump head after 2 to 5 operating hours (torque 4.05 ft-lb, 5.5 Nm).

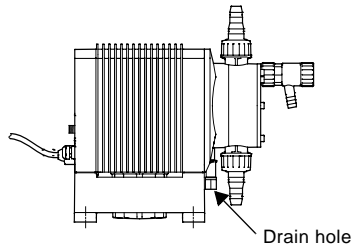

Fig. 1 Position of drain hole

3.4 Installation example

The DME pump can be installed in many different ways. The sketch below shows an example with side-fitted control panel. The tank is a Grundfos chemical tank.

US

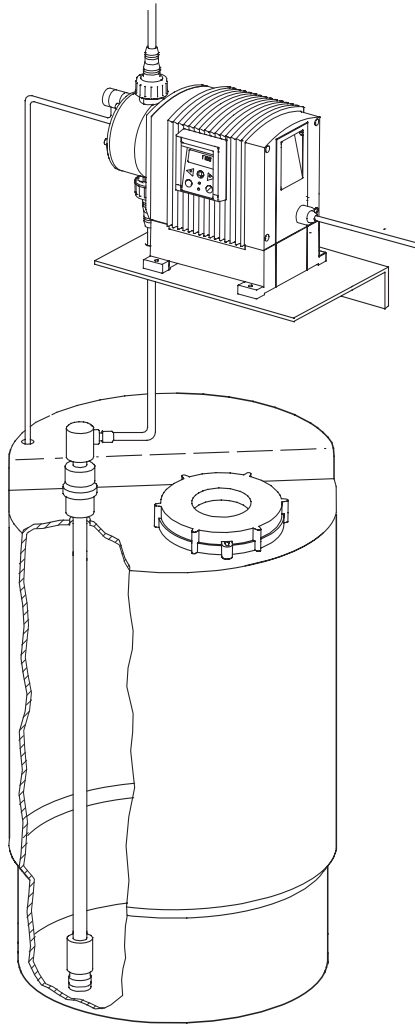

Fig. 2 Installation example

3.5 Electrical connection

- The electrical connection of the pump should be carried out by qualified persons in accordance with local regulations.
- For electrical data of the pump, see section 2.2.

TM03 0507 0105

4. Functions

4.1 Control panel

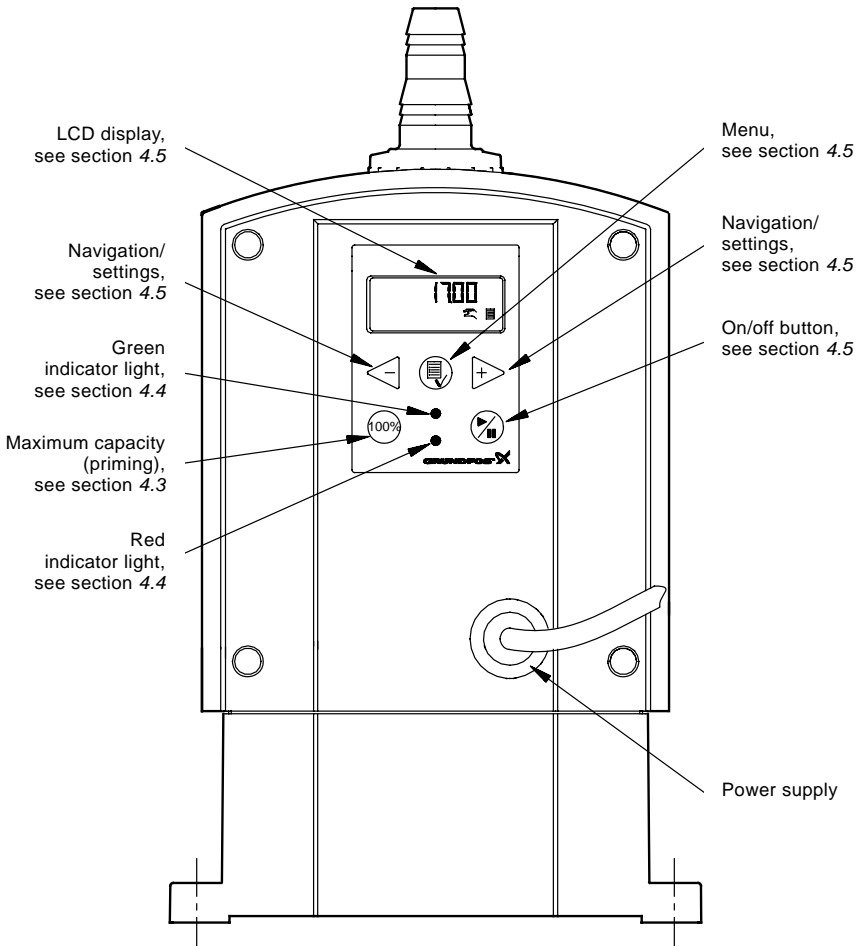



Fig. 3 Control panel functions

4.2 Start/stop of pump



The pump can be started/stopped locally on the pump control panel.

US

4.3 Priming/venting of pump

The pump control panel incorporates a  button. Press this button if the maximum pump capacity is required over a short period, e.g. during start-up. When the button is released, the pump automatically returns to the previous operating mode.

During priming/venting, it is recommended to let the pump run without a counter pressure or to open the vent valve.

NOTE: When the buttons  and  are pressed simultaneously, the pump can be set to run for a specific number of seconds at maximum capacity. The remaining number of seconds will appear in the display. The maximum value is 300 seconds.

4.4 Indicator lights

The green and red indicator lights on the pump are used for operating and fault indication.

The functions of the indicator lights appear from the table below:

Condition	Green LED	Red LED	Display
Pump running	On	Off	Normal indication
Set to stop	Flashing	Off	Normal indication
Pump fault* ¹	Off	On	EEPROM
Supply failure	Off	Off	OFF
Overheating	Off	On	MAX. TEMP.
Internal communication fault* ¹	Off	On	INT. COM.
Internal Hall fault* ¹	Off	On	HALL
Maximum pressure exceeded* ²	Off* ³	On	OVERLOAD
No motor rotation detected* ¹	Off	On	ORIGO

*¹ Please contact a Grundfos service center.

*² Alarms can be reset  when the faults have been corrected.

*³ The pump will make 10 attempts to restart before going into permanent OFF mode.

4.5 Menu

The pump features a user-friendly menu which is activated by pressing the  button. During start-up, all texts will appear in English language. To select language, see section 4.12.

All menu items are described in the following sections. When ✓ appears at a menu item, it means that this item is activated. By selecting "RETURN" anywhere in the menu structure, you will return to the operating display without changes.

US

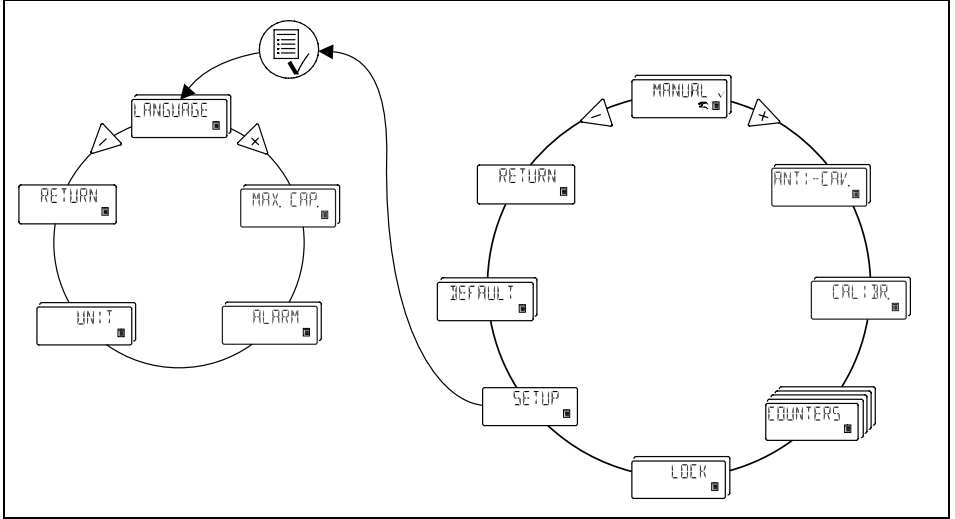
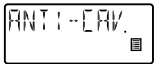

Fig. 4 Menu overview



See section 4.6



See section 4.7

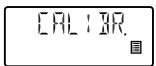

See section 6.



See section 4.9

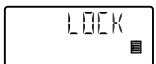

See section 4.15



See section 4.10



See section 4.11



See section 4.12

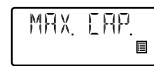

See section 4.8



See section 4.13



See section 4.14

4.6 Manual

The pump is dosing as constantly and evenly as possible, without any external signals.

Set the quantity to be dosed in l/h or gph. The pump automatically changes between the measuring units.

Setting range:

DME 60	0.0198 to 15.8 gph	75 ml/h to 60 l/h
DME 150	0.0528 to 39.2 gph	200 ml/h to 150 l/h
DME 375	0.132 to 99 gph	500 ml/h to 376 l/h
DME 940	0.317 to 248.3 gph	1200 ml/h to 940 l/h

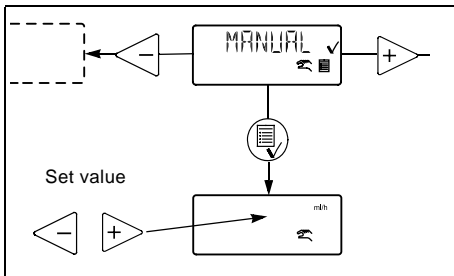

Fig. 5 Manual mode

4.7 Anti-cavitation

The pump features an anti-cavitation function. When this function is selected, the pump extends its suction stroke, resulting in optimized priming.

The anti-cavitation function is used:

- when pumping liquids of high viscosity,
- in the case of a long suction tube and
- in the case of a high suction lift.

Depending on the circumstances, the motor speed during the suction stroke can be reduced by 75%, 50% or 25% compared to the normal motor speed during the suction stroke.

The maximum pump capacity is reduced when the anti-cavitation function is selected. See section 2.1 Mechanical data.

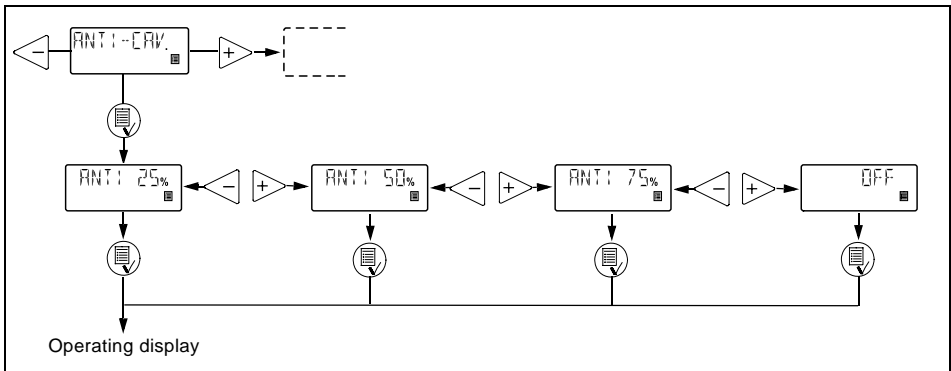



Fig. 6 Anti-cavitation function

4.8 Capacity limitation

This function offers the possibility of reducing the maximum pump capacity (MAX. CAP.). It influences the functions in which the pump is normally operating at maximum capacity.

Under normal operating conditions, the pump cannot operate at a capacity which is higher than the one stated in the display. This does not apply to the maximum capacity button , see section 4.3.

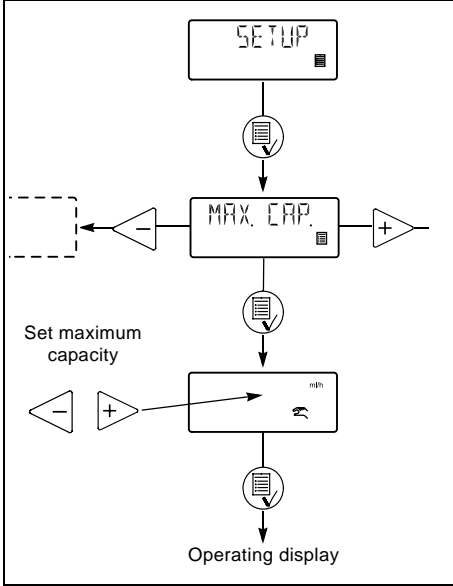

Fig. 7 Capacity limitation

4.9 Counters

The pump can display "non-resettable" counters for:

- **"QUANTITY"**
Accumulated value of dosed quantity in liters or US gallons.
- **"STROKES"**
Accumulated number of dosing strokes.
- **"HOURS"**
Accumulated number of operating hours.
- **"POWER ON"**
Accumulated number of times the electricity supply has been switched on.

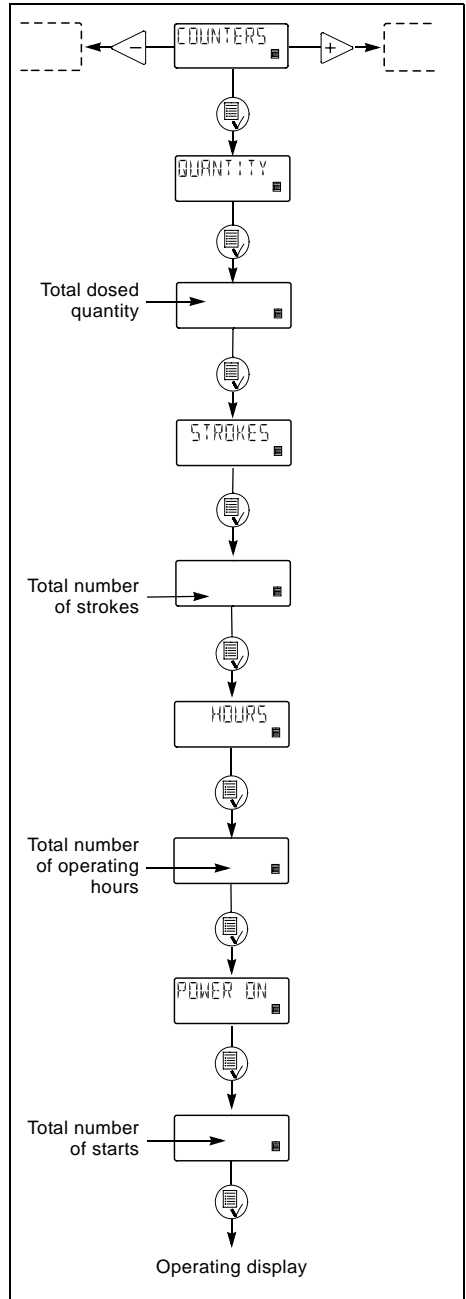

Fig. 8 Counters

4.10 Resetting

When "DEFAULT" is activated, the pump will return to the factory settings.

NOTE: The calibration is also set back to the default setting. This means that a new calibration is required when the "DEFAULT" function has been used.

Default settings are the factory settings of standard pumps. Select "DEFAULT" in the "MAIN" menu.

Default settings

Operating mode:	Manual
Capacity:	Maximum capacity
Control panel lock:	Unlocked
Default lock code:	2583
Anti-cavitation:	Not active
Capacity limitation:	Maximum capacity
Alarm reset required to restart the pump	
Language:	English
Units:	Metric

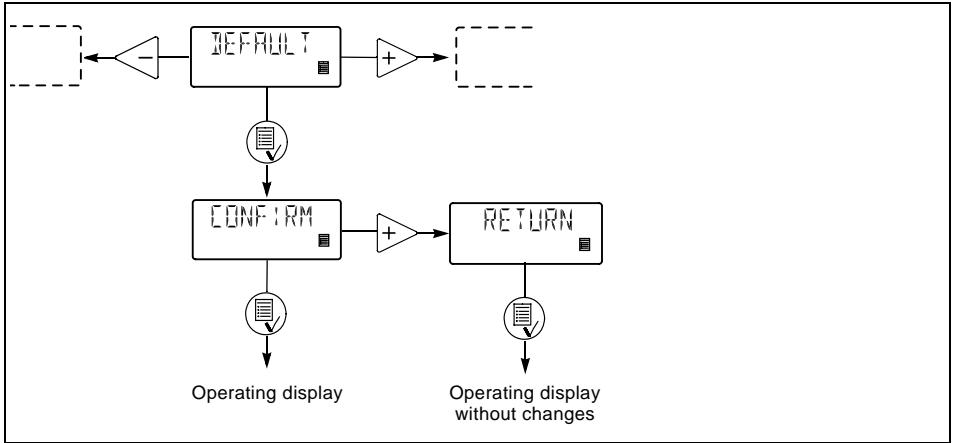

Fig. 9 Resetting

4.11 Return



Fig. 10 Return function

The "RETURN" function makes it possible to return from any level in the menu to the operating display without changes after the menu functions have been used.

4.12 Language

The display text can be displayed in one of the following languages:

- English
- German
- French
- Italian
- Spanish
- Portuguese
- Dutch
- Swedish
- Finnish
- Danish
- Czech
- Slovak
- Polish
- Russian

US

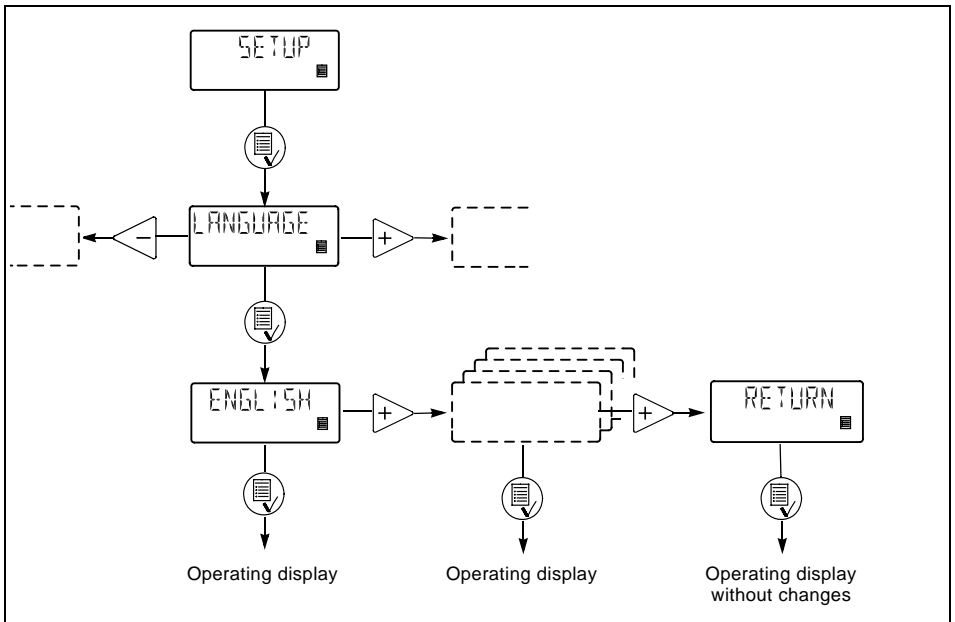

Fig. 11 Selection of language

4.13 Alarm

The alarm function can be set to "AUT. RES." or "MAN. RES."

4.14 Measuring units

It is possible to select metric units (liters/milliliters) or US units (gallons/milliliters).

Metric measuring units:

- Set the quantity to be dosed in liters per hour (l/h) or milliliters per hour (ml/h).
- **For calibration**, set the quantity to be dosed in ml per 100 strokes.
- Under the "QUANTITY" menu item in the "COUNTERS" menu, the dosed quantity is indicated in liters.

US measuring units:

- Set the quantity to be dosed in gallons per hour (gph).
- **For calibration**, set the quantity to be dosed in ml per 100 strokes.
- Under the "QUANTITY" menu item in the "COUNTERS" menu, the dosed quantity is indicated in US gallons (gal).

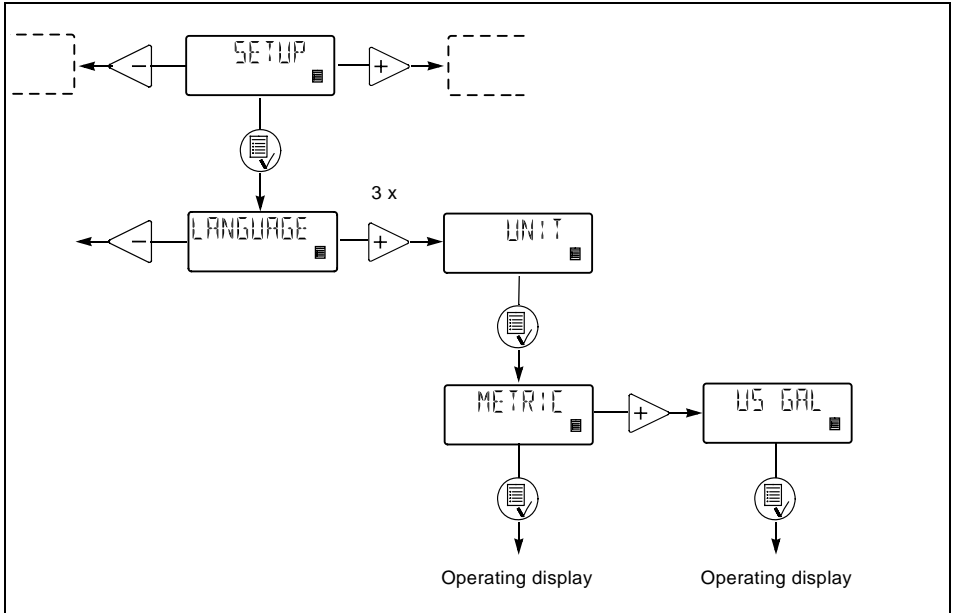

Fig. 12 Selection of measuring units

4.15 Control panel lock

It is possible to lock the buttons on the control panel to prevent maloperation of the pump. The locking function can be set to "ON" or "OFF". The default setting is "OFF".

A PIN code must be entered to change from "OFF" to "ON". When "ON" is selected for the first time, "_____" will appear in the display. If a code has already been entered, it will appear when an attempt to change to "ON" is made. This code can either be re-entered or changed.

If a code has already been entered, active digits are flashing.

If attempts are made to operate the pump in locked condition, "LOCKED" will appear in the display for 2 seconds, followed by "_____" . A code must be entered. If the entering of a code has not been started within 10 seconds, the operating display without changes will appear.

If a wrong code is entered, "LOCKED" will appear in the display for 2 seconds, followed by "_____" . A new code must be entered. If the entering of a code has not been started within 10 seconds, the operating display without changes will appear. This display will also appear if the entering of the correct code exceeds 2 minutes.

If the locking function has been activated but the control panel is unlocked, the control panel will be locked automatically if it is not operated for 2 minutes.

The locking function can also be reactivated by selecting "ON" in the "LOCK" menu. The previously entered code will then appear and must be re-entered by pressing the  button four times. The code can also be changed.

The control panel can be unlocked either by means of the selected code or the factory code 2583.

The following buttons and inputs are still active when the panel is locked:

- Priming (-button).
- On/off button.

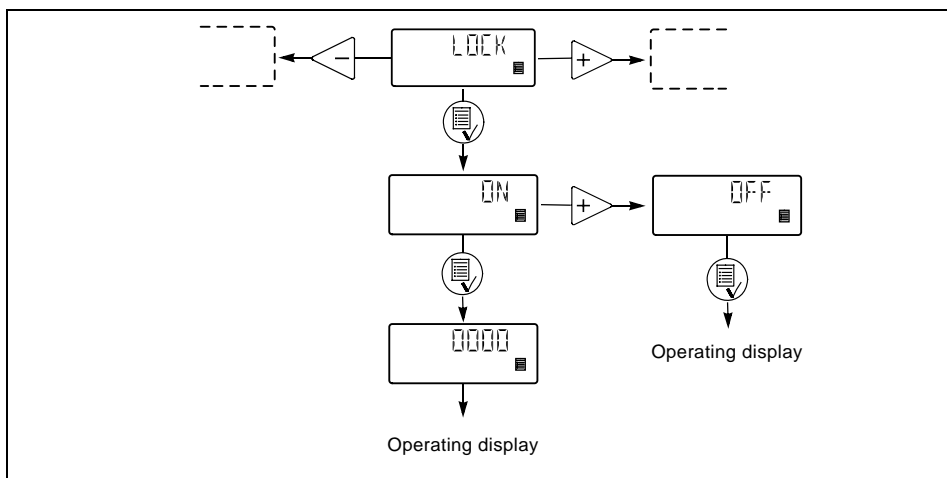











Fig. 13 Control panel lock

Activating the locking function and locking the control panel:

1. Select "LOCK" in the menu.
2. Select "ON" by means of the buttons  and  and confirm with .
3. Enter or re-enter a code by means of the buttons ,  and .



The locking function has now been activated and the control panel is locked.

Unlocking the control panel (without deactivating the locking function):

1. Press  once. "LOCKED" appears in the display for 2 seconds, followed by "_____" .
2. Enter the code by means of the buttons ,  and .

The control panel has now been unlocked and will automatically be locked again if the control panel is not operated for 2 minutes.

Deactivating the locking function:

1. Unlock the control panel as described above.
2. Select "LOCK" in the menu.
3. Select "OFF" by means of the buttons  and  and confirm with .

The locking function has now been deactivated and the control panel is unlocked.

* The panel can always be unlocked with code 2583.

5. Start-up

Step	Action
------	--------

US

1

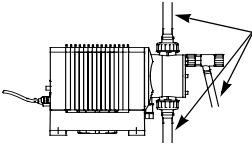

Connect the hoses/pipes:

- Connect the suction and dosing tubes/pipes to the pump.
- Connect a tube to the vent valve, if required, and lead the hose to the tank.

2

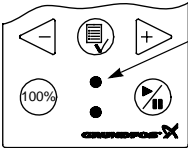

Switch on the electricity supply:

- The display is on.
- The green indicator light is flashing (the pump has stopped).
- Select language, if required, see section 4.12.

3

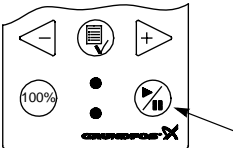

Start the pump:

- Start the pump by pressing the on/off button.
- The green indicator light is permanently on.

4

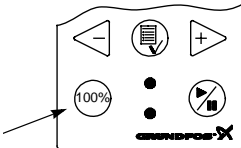

Priming/venting:

- Press the 100% button on the pump control panel and let the pump run without a counter pressure. Open the vent valve, if required. When the buttons 100% and on/off are pressed simultaneously during priming, the pump can be set to run for a specific number of seconds at maximum capacity.

5

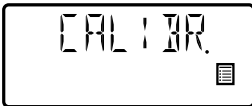

Calibration:

- When the pump has been primed and is running at the right counter pressure, calibrate the pump, see section 6.

If the pump is not operating satisfactorily, see section 9. *Fault finding chart*.

6. Calibration

It is important that the pump is calibrated after installation to ensure that the correct value (ml/h or l/h) appears in the display.

The calibration can be carried out in two different ways:

- **Direct calibration.** The dosed quantity of 100 strokes is measured directly. See section 6.1.
- **Check calibration.** See section 6.2.

US

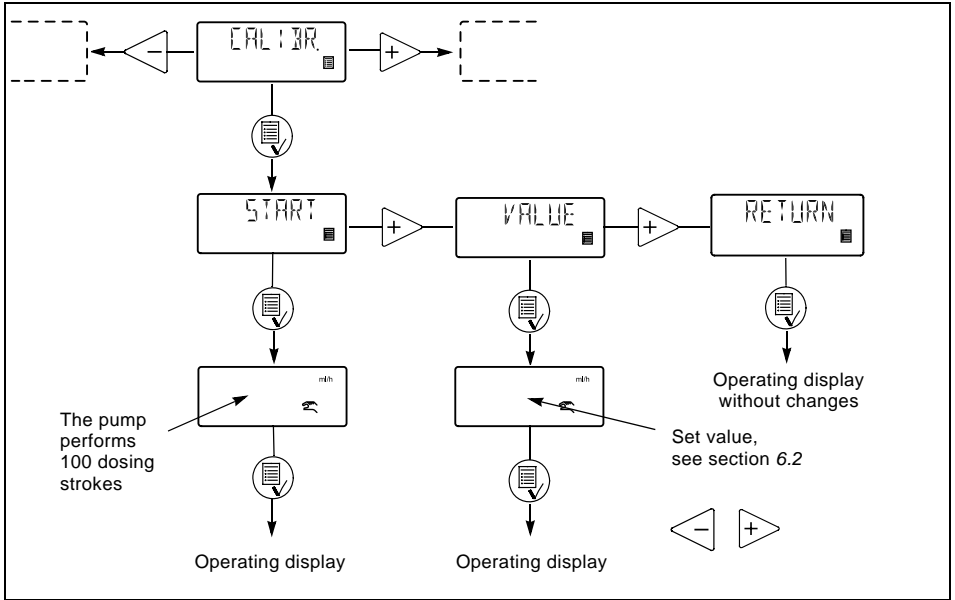

Fig. 14 Calibration







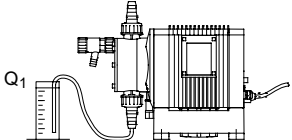

6.1 Direct calibration

Before calibration, make sure:

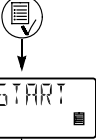
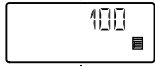
- that the pump is installed with foot valve, injection valve, etc. in the existing system.
- that the pump is running at the counter pressure it is supposed to operate at (adjust the counter pressure valve, if required).

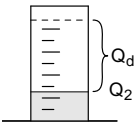
- that the pump is operating with the correct suction lift.

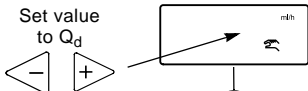
To carry out a direct calibration, proceed as follows:



Action	Pump display
1. Prime the dosing head and the suction tubing.	
2. Stop the pump. The green LED is flashing.	
3. Fill a graduated glass with dosing liquid, Q_1 . DME 60: approx. 1.5 l DME 150: approx. 2.5 l DME 375: approx. 6 l DME 940: approx. 14 l	
4. Read and note the quantity Q_1 .	
5. Place the suction tubing in the graduated glass.	
6. Go to the calibration menu, see section 4.5.	
7. Press the  button twice.	
8. The pump is performing 100 dosing strokes.	
9. The factory-calibration value appears in the display.	
10. Remove the suction tubing from the graduated glass and read Q_2 .	
11. Set the display value to $Q_d = Q_1 - Q_2$.	
12. Confirm with the  button.	
13. The pump is now calibrated and returns to the operating display.	

6.2 Check calibration

In check calibration, the calibration value is calculated by reading the consumption of chemical in a specific period and comparing this with the number of dosing strokes performed in the same period.

This calibration method is very accurate and especially suitable for check calibration after long periods of operation or if direct calibration is impossible. The calibration can for instance be carried out when the chemical tank is replaced or filled.

To carry out a check calibration, proceed as follows:

1. Stop the pump by pressing the  button.
2. Read the counter and note the number of dosing strokes, see section 4.9.
3. Read and note the quantity in the chemical tank.
4. Start the pump by pressing the  button and let it run for at least 1 hour. The longer the pump is operating, the more accurate the calibration will be.
5. Stop the pump by pressing the  button.
6. Read the counter and note the number of dosing strokes, see section 4.9.
7. Read and note the quantity in the chemical tank.
8. Calculate the dosed quantity in ml and the number of dosing strokes performed during the operating period.
9. Calculate the calibration value as follows:
(dosed quantity in ml/dosing strokes) x 100.
10. Set the calculated value in the calibration menu.

7. Maintenance

The pump drive assembly is maintenance-free. However, it is recommended to keep the pump clean.

Grundfos dosing pumps are produced according to the highest quality standards. Primary wear parts include the diaphragm, valve seats, and valve balls.

To ensure long life and to reduce the risk of disturbance of operation, visual checks should be carried out regularly.

It is possible to order dosing heads, valves and diaphragms in materials which are suitable for the specific liquid to be pumped. See the product numbers at the end of these instructions.

8. Service

Before returning the pump to Grundfos for service, the **safety declaration** at the end of these instructions must be filled in by authorized personnel and attached to the pump in a visible position.

NOTE: If a pump has been used for a liquid which is injurious to health or toxic, the pump will be classified as contaminated.

If Grundfos is requested to service the pump, it must be ensured that the pump is free from substances that can be injurious to health or toxic. If the pump has been used for such substances, the pump must be cleaned before it is returned.

If proper cleaning is not possible, all relevant information about the chemical must be provided.

If the above is not fulfilled, Grundfos can refuse to accept the pump for service. Possible costs of returning the pump are paid by the customer.

The safety declaration can be found at the end of these instructions (only in English).

NOTE: For safety reasons, the replacement of the supply cable must be carried out by an authorized Grundfos service center.

9. Fault finding chart

Fault	Cause	Remedy
US The dosing has stopped or the output is too low.	Valves leaking or blocked.	Check and clean valves.
	Valves incorrectly installed.	Remove and fit valves. Check that the arrow on the valve casing is pointing in the liquid flow direction. Check that all O-rings have been fitted correctly.
	Suction valve or suction pipe/hose leaking or blocked.	Clean and seal the suction pipe/hose.
	Suction lift too high.	Install the pump in a lower position. Install a priming tank.
	Viscosity too high.	Select the anti-cavitation function, see section 4.7.
		Install a pipe/hose with larger cross-section. Fit spring-loaded valves.
Pump out of calibration.	Calibrate the pump, see section 6.	
Pump dosing too little or too much.	Pump out of calibration.	Calibrate the pump, see section 6.
Pump dosing irregularly.	Valves leaking or blocked.	Check and clean the valves.
Leakage from drain hole.	Diaphragm defective.	Install a new diaphragm.
Frequent diaphragm failures.	Diaphragm not fastened properly.	Install a new diaphragm and ensure that the diaphragm is fastened properly.
	Counter-pressure too high (measured at the pump discharge port).	Check the system. Check the injection valve.
	Sediment in dosing head.	Clean/flush the dosing head.

10. Disposal

This product or parts of it must be disposed of in an environmentally sound way:

1. Use the public or private waste collection service.
2. If this is not possible, contact the nearest Grundfos company or service workshop.

Subject to alterations.

Service kits, DME

Pump size	Valves	Connectors	Materials Dosing head/ Gaskets/ Valves	Complete dosing head with NPT connectors (no hose clamp connectors incl.)
DME 60	Standard	PVC 3/4" NPT	PP/EPDM/Ceramics	96549401
			PP/FKM/Ceramics	96549402
			PVDF/FKM/Ceramics	96549403
			Stainless steel/FKM/Stainless steel	96549404
	Spring loaded		PP/EPDM/Ceramics	96549405
			PP/FKM/Ceramics	96549406
			PVDF/FKM/Ceramics	96549407
			Stainless steel/FKM/Stainless steel	96549408
DME 150	Standard		PP/EPDM/Ceramics	96549409
			PP/FKM/Ceramics	96549431
			PVDF/FKM/Ceramics	96549432
			Stainless steel/FKM/Stainless steel	96549433
	Spring loaded		PP/EPDM/Ceramics	96549434
			PP/FKM/Ceramics	96549435
			PVDF/FKM/Ceramics	96549436
			Stainless steel/FKM/Stainless steel	96549437
DME 375	Standard	PVC 1 1/4" NPT	PP/EPDM/Glass	96561182
			PP/FKM/Glass	96561183
			PVDF/FKM/Glass	96561184
			Stainless steel/FKM/Stainless steel	96561185
	Spring loaded		PP/EPDM/Glass	96561186
			PP/FKM/Glass	96561187
			PVDF/FKM/Glass	96561188
			Stainless steel/FKM/Stainless steel	96561189
DME 940	Standard		PP/EPDM/Glass	96561200
			PP/FKM/Glass	96561201
			PVDF/FKM/Glass	96561202
			Stainless steel/FKM/Stainless steel	96561203
	Spring loaded		PP/EPDM/Glass	96561204
			PP/FKM/Glass	96561205
			PVDF/FKM/Glass	96561206
			Stainless steel/FKM/Stainless steel	96561207

Front cover	96520502
Vent valve pos. 1	PP/EPDM/Ceramics 96520488
	PP/FKM/Ceramics 96520489
	PVDF/FKM/Ceramics 96520500
	SS/KFM/SS 96520501

Power cord	Schuko 96440333
	US 96440334
	Schweiz 96460537
	Japan 96460769
	Australia 96460770
	U.K. 96460772

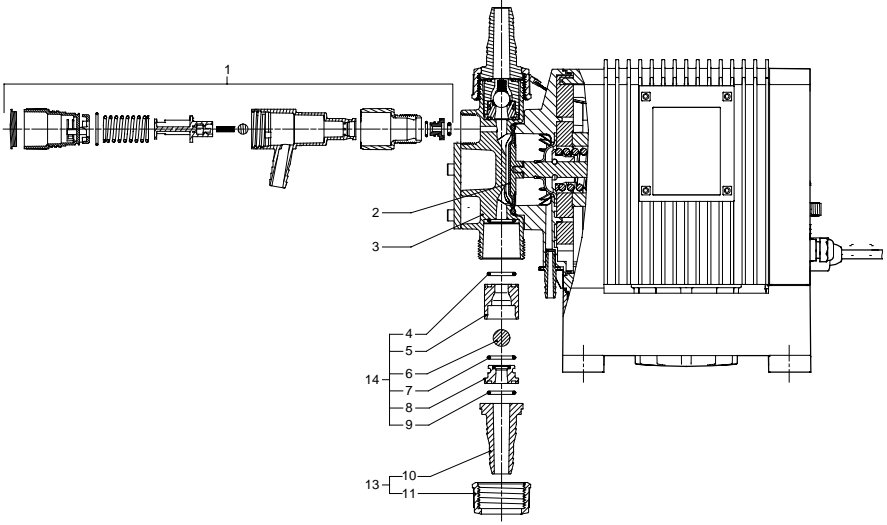

TMO 27064 2503

Dimensions

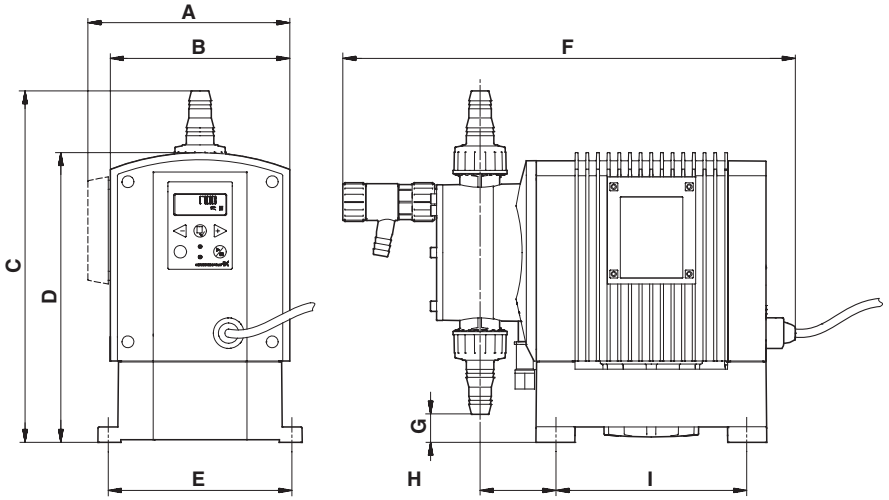

TM03 0513 0105

Dimensions are in inches (mm)

	DME 60		DME 150		DME 375		DME 940	
A	6.93	(176)	6.93	(176)	9.37	(238)	9.37	(238)
B	7.8	(198)	7.8	(198)	8.58	(218)	8.58	(218)
C	13.03	(331)	13.58	(345)	18.54	(471)	19.53	(496)
D	11.18	(284)	11.18	(284)	14.33	(364)	14.33	(364)
E	7.09	(180)	7.09	(180)	9.06	(230)	9.06	(230)
F	17.48	(444)	17.48	(444)	21.26	(540)	21.22	(539)
G	1.61	(41)	1.10	(28)	1.22	(31)	0.24	(6)
H	2.91	(74)	2.91	(74)	3.74	(95)	3.74	(95)
I	7.36	(187)	7.36	(187)	9.69	(246)	9.69	(246)

CERTIFICATE OF CLEANLINESS

HEALTH AND SAFETY CLEARANCE FORM

Please copy, fill in, sign this form and attach it to the pump returned for service along with a return material authorization number.

Product Description _____
Product Number _____ RMA # _____ Quantity _____

APPLICATION: The referenced product has been exposed to toxic or hazardous materials:
 YES NO If yes, complete SECTION A. If no, continue to SECTION B.

SECTION A: TOXIC CLEARANCE

(To be completed if applied substances ARE hazardous)

Please specify all hazardous materials/substances used with the referenced product(s).

Provide the Material Safety Data Sheet for all materials referenced or list precautions to be taken when handling these substances. Also, provide any actions to be taken in the event of human contact with any liquid within the product (even after cleaning and/or flushing).

The product returned has been decontaminated, drained of liquid and is safe to handle. Provide decontamination method used.

_____ Initial/Date _____

SECTION B: NON-TOXIC CLEARANCE

(To be completed if applied substances ARE NOT hazardous)

The product returned has not handled or been in contact with any toxic or hazardous substances. The product has been drained of liquid and is safe to handle.

_____ Initial/Date _____

I hereby declare that the contents of this consignment are fully and accurately described above by proper shipping name and are classified, packed, marked and labeled, and are in all respects in proper condition for transport, by all modes, according to applicable international and national governmental regulations. Health and safety issues are clearly understood and will be given consideration during shipment. (A repair or inspection of product will only be undertaken when this certificate has been completed and authorized by a qualified member of staff employed by the returning company.)

COMPANY NAME _____

NAME _____ POSITION _____

SIGNATURE _____ PHONE _____

A return material authorization number from Grundfos, along with a completed and signed copy of this form must accompany the returned product. It is the senders responsibility to package, transport and complete the shipping documents regarding the nature of the product shipped. Irrespective of this, Grundfos reserves the right to reject the service order for other reasons. Grundfos will rely on this representation and will look to the customer for reimbursement of any and all costs, claims or damages incurred, including attorney's fees, if any representation is not correct.
Radioactive products will not be accepted for repair.

U.S.A.

GRUNDFOS Pumps Corporation
17100 West 118th Terrace
Olathe, Kansas 66061
Phone: +1-913-227-3400
Telefax: +1-913-227-3500

Canada

GRUNDFOS Canada Inc.
2941 Brighton Road
Oakville, Ontario
L6H 6C9
Phone: +1-905 829 9533
Telefax: +1-905 829 9512

México

Bombas GRUNDFOS de México
S.A. de C.V.
Boulevard TLC No. 15
Parque Industrial Stiva
Aeropuerto
Apodaca, N.L.C.P. 66600
Phone: +52-81-8144 4000
Telefax: +52-81-8144 4010

9650007 0107	172
Repl. 9650007 0105	