

CUP PLATE MOUNT

29	1	CUP PLATE
23	1	SHOE
22	1	FLAT WASHER
21	1	LOCK WASHER
20	1	HEX NUT
19	1	HEX HEAD CAP SCREW
18	1	BALL MOUNT
13	1	OIL SEAL
12	6	LOCK WASHER
11	6	HEX HEAD CAP SCREW
NO.	QTY	PART NAME

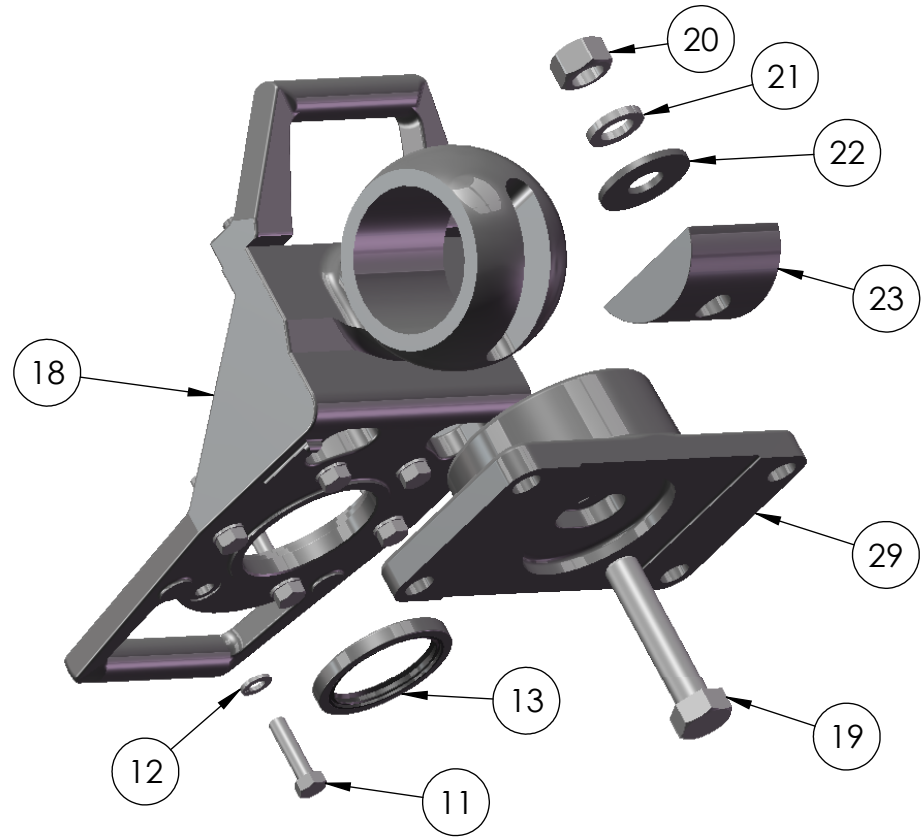

CLAMP MOUNT

24	1	CLAMP ASSEMBLY
23	1	SHOE
22	1	FLAT WASHER
21	1	LOCK WASHER
20	1	HEX NUT
19	1	HEX HEAD CAP SCREW
18	1	BALL MOUNT
13	1	OIL SEAL
12	6	LOCK WASHER
11	6	HEX HEAD CAP SCREW
NO.	QTY	PART NAME

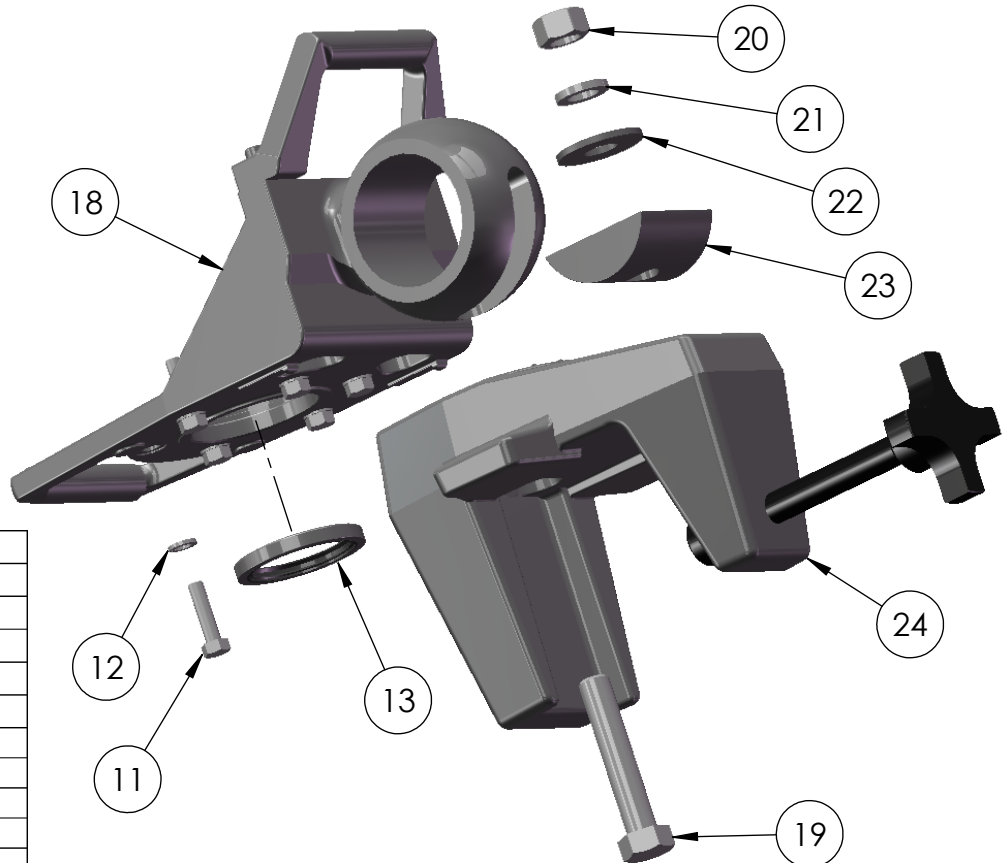

* ALL DIMENSIONS AND WEIGHTS ARE FOR REFERENCE ONLY UNLESS THE DRAWING IS CERTIFIED.

* ALL EQUIPMENT DESIGN AND APPLICATION DATA SHOWN HEREIN IS CONFIDENTIAL AND THE PROPERTY OF BRAUN MIXER. NO USE OR DISCLOSURE THEREOF MAY BE MADE WITHOUT OUR WRITTEN PERMISSION.



12838 Stainless Drive
Holland, MI 49424

PH: 616-399-5600
FAX: 616-399-3084

MIXER MODEL
BD/BGM BALL MOUNT
ASSEMBLY
DIMENSION AND ASSEMBLY DRAWING

DRAWN BY: BSB DATE: 9/13/2018 © 2018

APPROVED BY: DATE:

DWG. NO. **A- TK0163B**

REV.