

MA-75M(L X H)

QUINTUPLEX PLUNGER PUMP

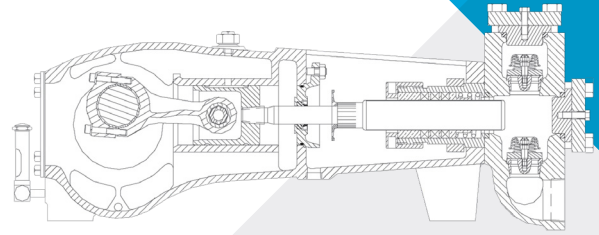

No. of plungers.....	5
Maximum rated speed.....	550 rpm
Stroke length.....	2.75 in. 69.9 mm
Maximum rated power.....	75.0 hp 55.9 kW
Maximum rod load	3535 lbs. 15.69 kN
Weight MA-75M.....	1270 lbs.
MA-75L.....	1435 lbs.
MA-75H.....	1325 lbs.

ENGLISH UNITS
MA-75M

PLUNGER SIZE in.	STUFFING BOX BORE in.	MAX psi	*GALLON PER/REV.	250 RPM US GPM	350 RPM US GPM	450 RPM US GPM	550 RPM US GPM
2.250	2.875	889	0.2367	59.2	82.8	106.5	130.2
2.125	2.875	997	0.2112	52.8	73.9	95.0	116.1
2.000	2.875	1125	0.1870	46.7	65.4	84.1	102.8
1.875	2.875	1280	0.1643	41.1	57.5	74.0	90.4
1.750	2.875	1468	0.1432	35.8	50.1	64.4	78.7
1.625	2.500	1704	0.1234	30.9	43.2	55.6	67.9
1.500	2.500	1998	0.1052	26.3	36.8	47.3	57.9
1.375	2.250	2379	0.0884	22.1	30.9	39.8	48.6
1.250	2.250	2878	0.0730	18.3	25.6	32.9	40.2
1.125	1.750	3000	0.0591	14.8	20.7	26.6	32.5
hp REQUIRED @ rpm				34.1	47.6	61.3	75.0

METRIC UNITS
MA-75M

PLUNGER SIZE mm	STUFFING BOX BORE mm	MAX PRESS. bar	*LITER PER/REV.	250 RPM LPM	350 RPM LPM	450 RPM LPM	550 RPM LPM
57.2	73.0	61.3	0.8961	224.0	313.6	403.2	492.8
54.0	73.0	68.7	0.7992	199.8	279.7	359.6	439.5
50.8	73.0	77.6	0.7080	177.0	247.8	318.6	389.4
47.6	73.0	88.3	0.6220	155.5	217.7	279.9	342.1
44.5	73.0	101.2	0.5422	135.5	189.8	244.0	298.2
41.3	63.5	117.5	0.4672	116.8	163.5	210.2	256.9
38.1	63.5	137.8	0.3983	99.6	139.4	179.2	219.0
35.0	57.2	164.0	0.3347	83.7	117.1	150.6	184.1
31.8	57.2	198.4	0.2764	69.1	96.7	124.4	152.0
28.6	44.5	206.8	0.2238	55.9	78.3	100.7	123.1
KW REQUIRED @ rpm				25.1	35.5	45.7	55.9

ENGLISH UNITS
MA-75L

PLUNGER SIZE in.	STUFFING BOX BORE in.	MAX psi	* GALLON PER/REV.	250 RPM US GPM	350 RPM US GPM	450 RPM US GPM	550 RPM US GPM
2.750	3.500	595	0.3535	88.4	123.7	159.1	194.4
2.625	3.500	653	0.3222	80.6	112.8	145.0	177.2
2.500	3.250	720	0.2922	73.1	102.3	131.5	160.7
2.375	3.250	798	0.2637	65.9	92.3	118.7	145.0
2.250	2.875	889	0.2367	59.0	82.9	106.5	130.2
hp REQUIRED @ rpm				34.0	47.6	61.3	75.0

METRIC UNITS
MA-75L

PLUNGER SIZE mm	STUFFING BOX BORE mm	MAX PRESS. bar	*LITER PER/REV.	250 RPM LPM	350 RPM LPM	450 RPM LPM	550 RPM LPM
69.9	88.9	41.0	1.3384	334.6	468.4	602.3	736.1
66.7	88.9	45.0	1.2198	305.0	426.9	548.9	670.9
63.5	82.6	49.6	1.1063	276.6	387.2	497.8	608.5
60.3	82.6	55.0	0.9984	249.6	349.4	449.3	549.1
57.2	73.0	61.3	0.8961	224.0	313.6	403.2	492.9
KW REQUIRED @ rpm				25.3	35.5	45.7	55.9

ENGLISH UNITS

MA-75H

PLUNGER SIZE in.	STUFFING BOX BORE in.	MAX psi	* GALLON PER/REV.	150 RPM US GPM	250 RPM US GPM	350 RPM US GPM	450 RPM US GPM	550 RPM US GPM
1.125	1.750	3553	0.059	8.9	14.8	20.7	26.6	32.5
1.000	1.750	4497	0.047	7.0	11.7	16.4	21.0	25.7
0.875	1.500	5000	0.036	5.4	8.9	12.5	16.1	19.7
hp REQUIRED @ rpm				20.4	34.1	47.7	61.3	75.0

METRIC UNITS

MA-75H

PLUNGER SIZE mm	STUFFING BOX BORE mm	MAX PRESS. bar	* LITER PER/REV.	150 RPM LPM	250 RPM LPM	350 RPM LPM	450 RPM LPM	550 RPM LPM
28.6	44.5	244.9	0.224	33.6	56.0	78.4	100.8	123.2
25.4	44.5	310.2	0.177	26.6	44.3	62.0	79.7	97.5
22.2	38.1	344.7	0.136	20.3	33.9	47.4	61.0	74.5
kW REQUIRED @ rpm				15.2	25.4	35.6	45.7	55.9

*Displacement based on 100% Volumetric Efficiency

$$l_{hp} = \frac{USGPM \times (\text{Discharge psig} - 1/2 \text{ Suction psig})}{1542}$$

$$PUMP \text{ rpm} = \frac{USGPM \text{ Desired}}{USGPM \text{ per Revolution of Selected Plunger}}$$

Power based on 90% Mechanical Efficiency

$$l_{kW} = \frac{M^3/HR \times (\text{Discharge Bar} - 1/2 \text{ Suction Bar})}{32.4}$$

$$PUMP \text{ rpm} = \frac{M^3/HR \text{ Desired}}{M^3 \text{ per Revolution of Selected Plunger}}$$

MA-75M Quintuplex Pump (Measurements shown in inches)

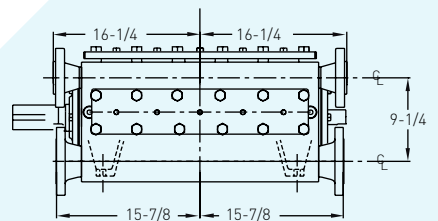
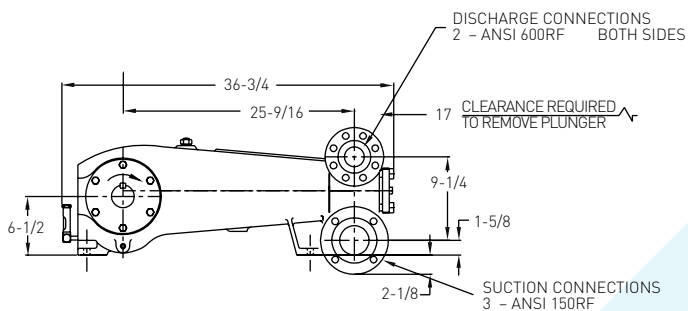
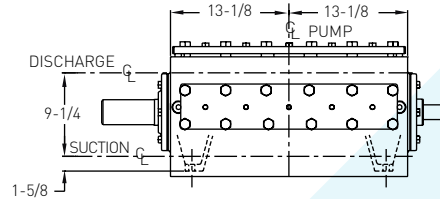
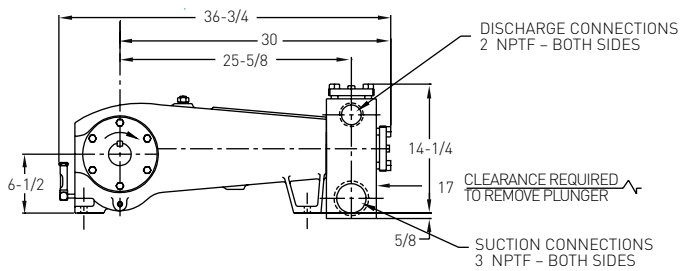
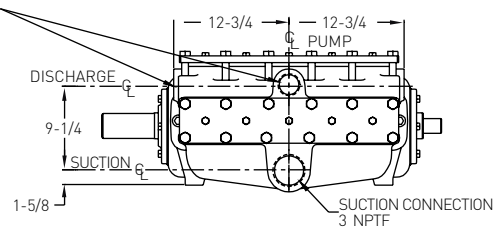
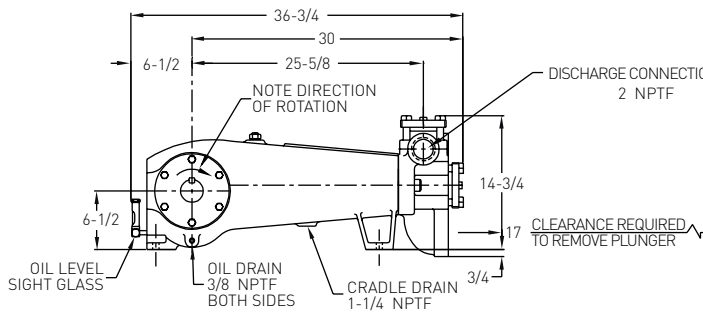
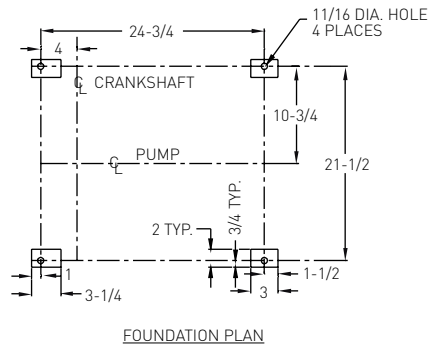
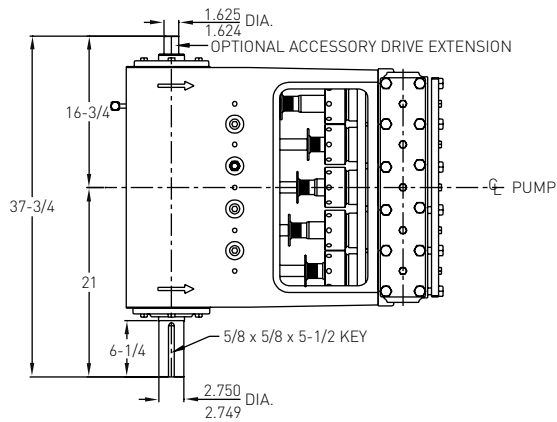

MA-75L Quintuplex Pump (Measurements shown in inches)

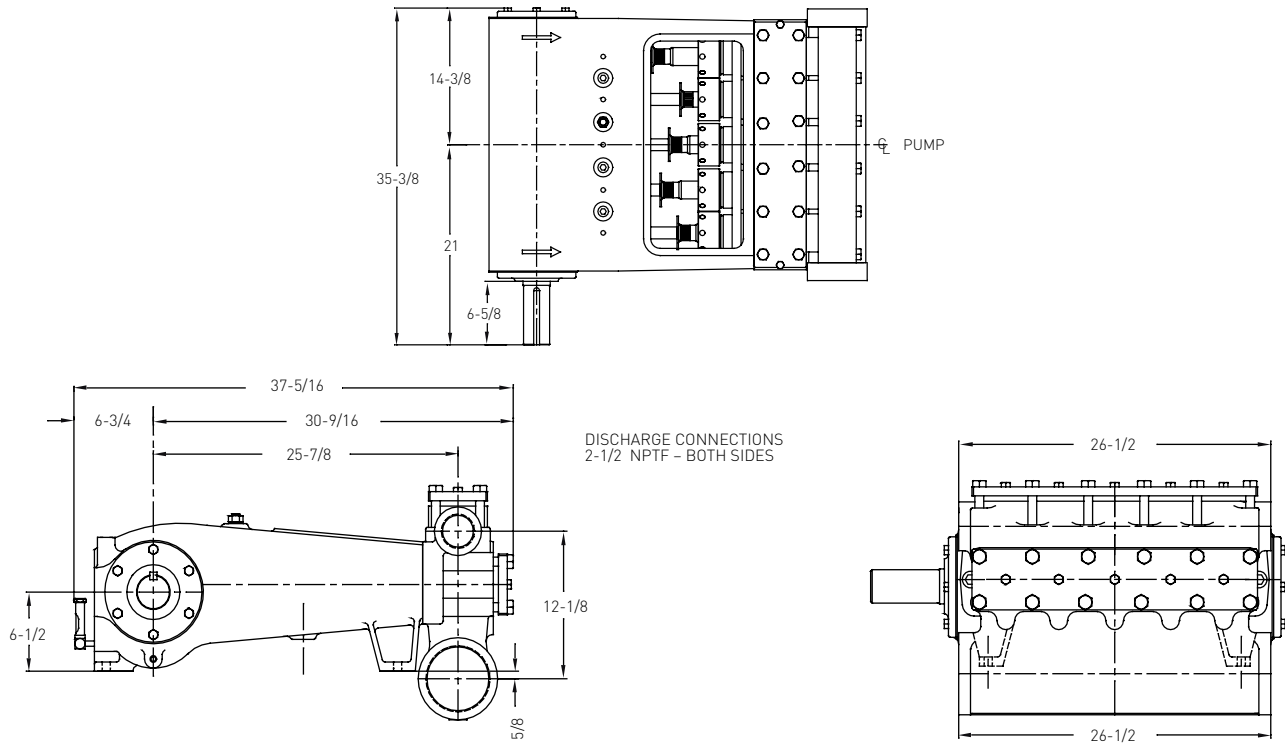

MA-75H Quintuplex Pump

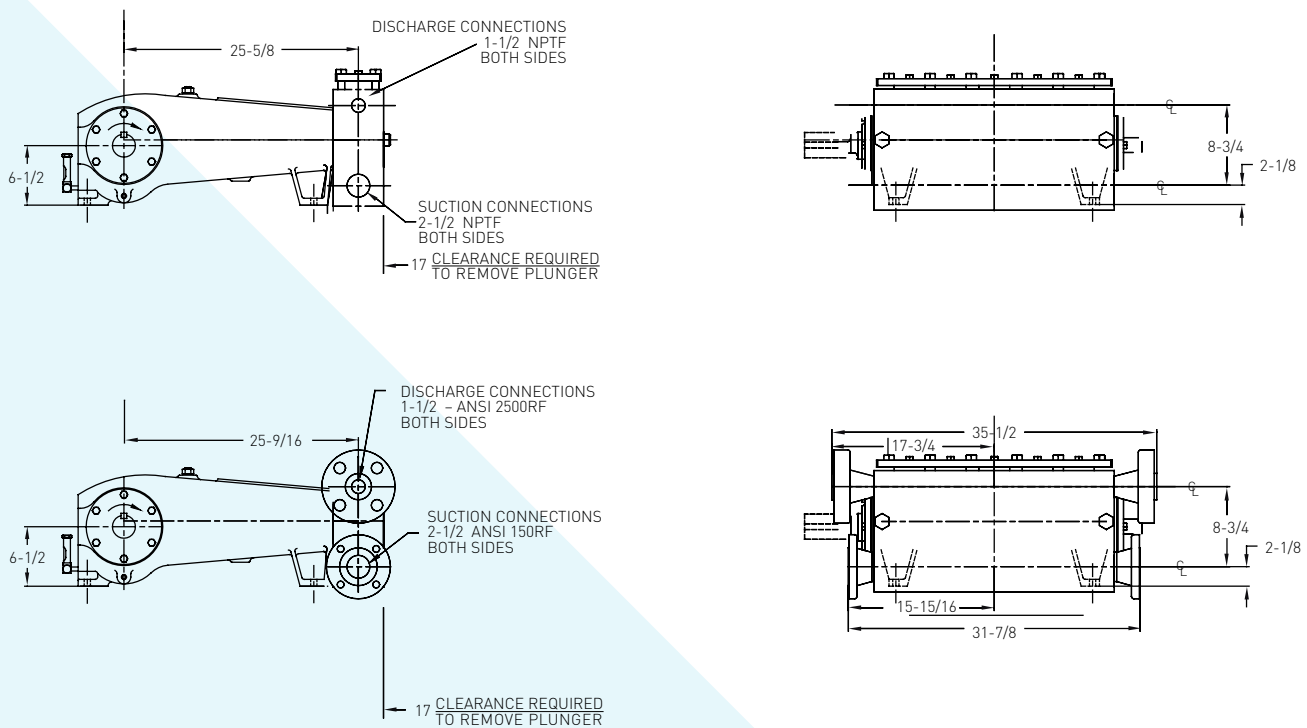

ENGINEERING DATA

Seals, Stuffing Boxes, Valve Covers, Cyl. Heads	Nitrile
Available Valve Types	
Standard, Acetal Resin MA-75M, 75L	Acetal
Standard, Hardened and Lapped MA-75H	17-4PH S.ST.
Optional, Hardened and Lapped MA-75M, 75L	17-4PH S.ST.
Optional, Abrasion Resistant MA-75M, 75H ,75L	17-4PH S.ST.
Valve Spring Material	Inconel®
Valve Seat, Liquid Passage Area	
Plate (Disc) Valves, (Acetal or S.ST.) MA-75M	2.3 sq.in.
MA-75L	2.4 sq.in.
Plate (Disc) Valves MA-75H	1.4 sq.in.
Abrasion Resistant Valve MA-75H	1.07 sq.in.
MA-75L	2.40 sq.in.
MA-75M	0.70 sq.in.
Avg. Liquid Velocity @ 550 rpm	
thru Disc Valves MA-75M	7.3 fps
MA-75L	10.4 fps
MA-75H	2.7 fps
thru Abrasion Resistant Wing Guided MA-75M	15.6 fps
MA-75L	10.4 fps
thru Suction Manifold MA-75M	5.9 fps
MA-75L	3.2 fps
MA-75H	1.9 fps
thru Discharge Manifold MA-75M	13.3 fps
MA-75L	12.7 fps
MA-75H	5.4 fps

MA-75M Quintuplex Pump (Measurements shown in inches)

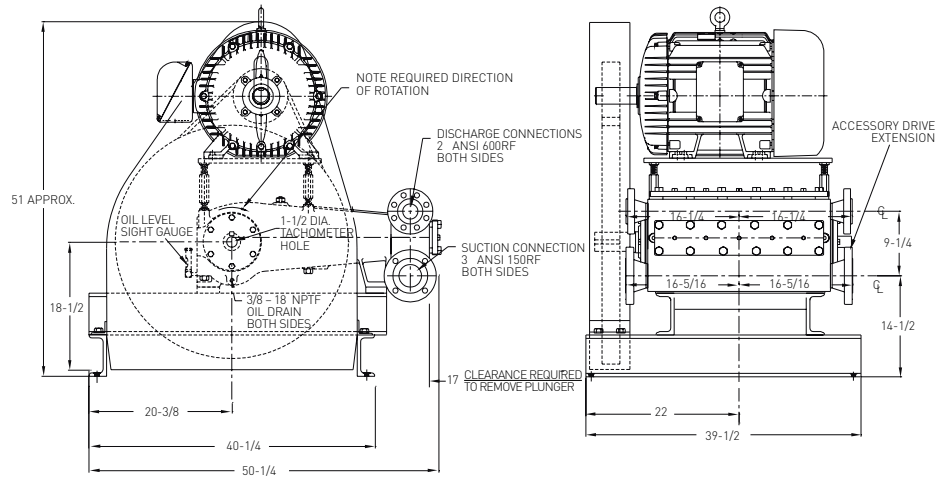
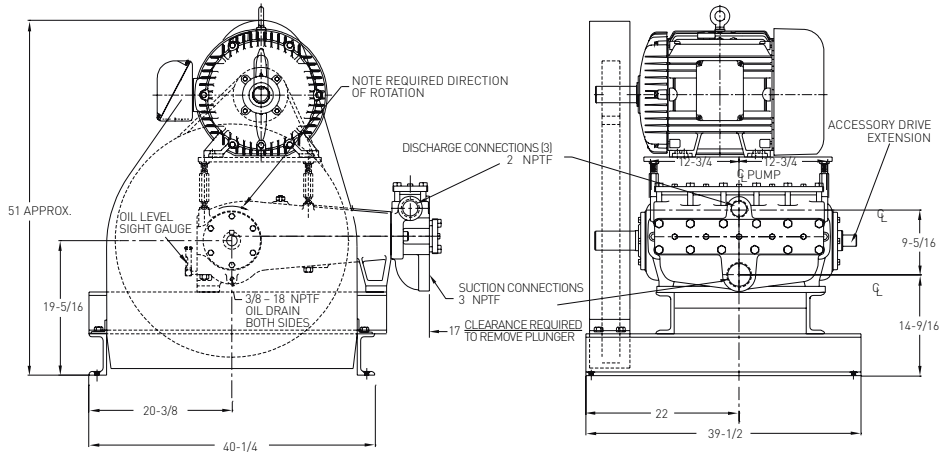

MA-75L Quintuplex Pump (Measurements shown in inches)

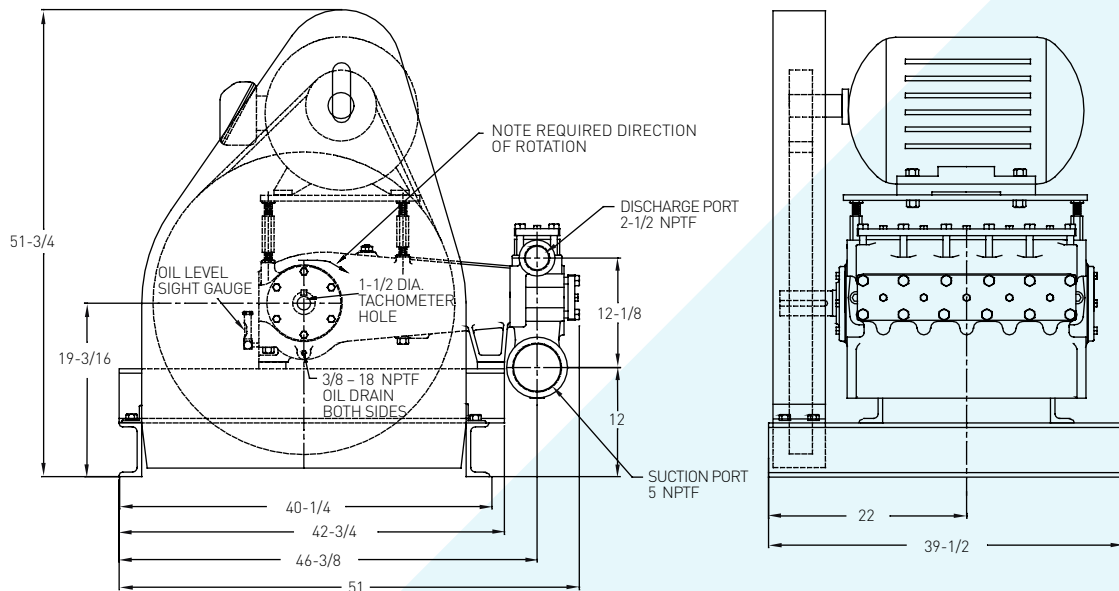

MA-75H Quintuplex Pump (Measurements shown in inches)

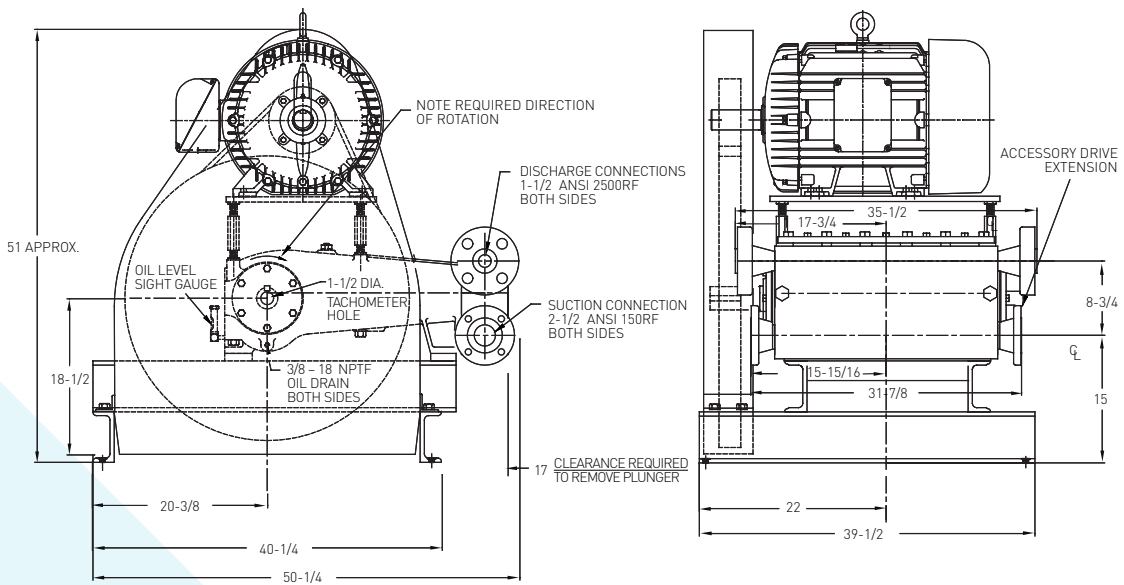
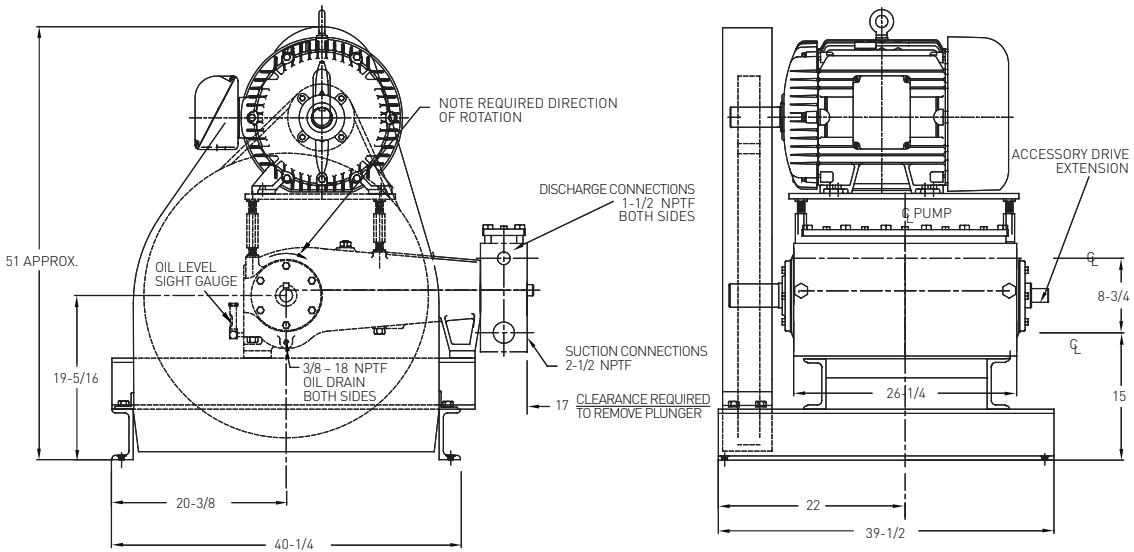

1101 MYERS PARKWAY,
ASHLAND, OHIO 44805

490 PINEBUSH ROAD, UNIT 4,
CAMBRIDGE, ONTARIO N1T 0A5

PENTAIR.COM/MYERS

Inconel® is a registered trademark of the Special Metals family of companies.
Timken® is a registered trademark of The Timken Company.
Myers® is a registered trademark of Pentair.

Pentair trademarks and logos are owned by Pentair or its affiliates. Third party registered and unregistered trademarks and logos are the property of their respective owners because we are continuously improving our products and services, Pentair reserves the right to change specifications without prior notice. Pentair is an equal opportunity employer.

MA1016 [07/15/20] ©2020 Pentair. All Rights Reserved.