

LEAKAGE ACCUMULATOR

POWER FRAMES 4 & 5 ONLY

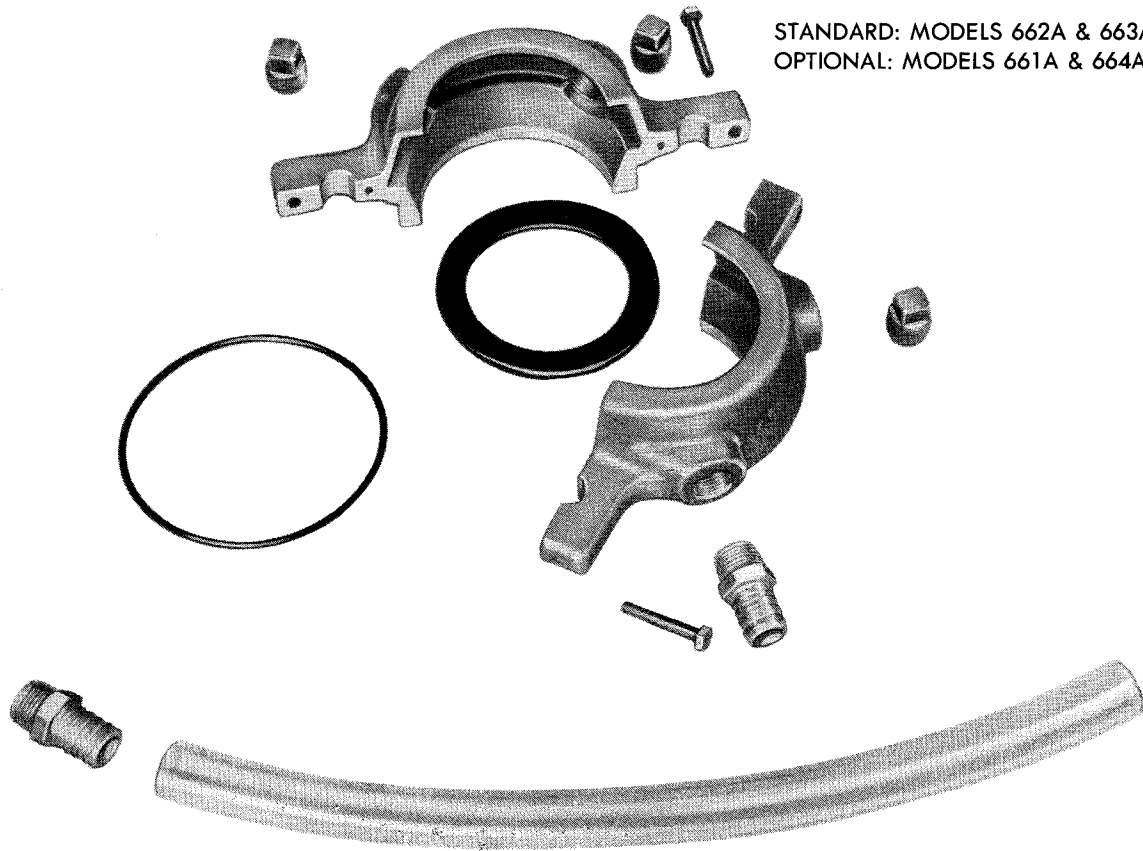

STANDARD: MODELS 662A & 663A
 OPTIONAL: MODELS 661A & 664A

The leakage accumulator gland (sprayless, dripless packing gland) is designed and constructed to prevent the collection of packing leakage in the pump bracket of a vertical or horizontally mounted pump. The leakage accumulator gland has a volute shape with two symmetrical halves. This gland encloses the water slinger preventing any spray from escaping and contaminating the area. The leakage is efficiently directed to a drain connection.

The two gland halves are doweled, bolted together, and sealed at the parting line with a soft liquid sealant. An "O" ring seal between the gland and packing box prevents any leakage in this area. One of the pipe tap ports on the side of the gland is fitted with a hose connector and a clear plastic section of hose, to both drain off and allow visual inspection of the leakage. The remaining ports have pipe plugs, but may be used for maintenance purposes to flush & drain debris from the accumulator.

AURORA MODEL 660 PUMP OPTIONS

SECTION 660 PAGE 167

DATED NOVEMBER 1988

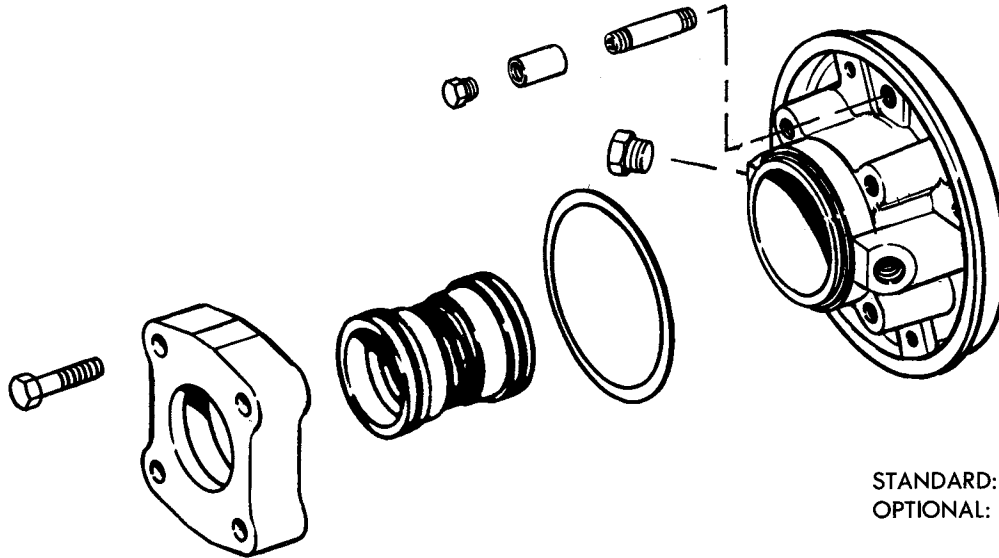

STANDARD: MODEL 664A
OPTIONAL: MODELS 661A, 662A & 663A

Double mechanical seals are recommended for gritty or abrasive applications. Seal faces are protected by clear water under pressure, injected directly into the seal cavity. Pressure in the seal box must be fifteen (15) lbs. higher than the operating pressure at the stuffing box of the pump. This forces the inner sealing faces closed and provides both faces with a film of clear sealant. If this is not done, abrasive particles may be forced under the sealing faces hastening wear. Even when the pump is not running, a pressure differential, or at least equal pressure in the seal box, is desirable. The sealant circulation for most pumping operations may be dead ended in the stuffing box. Pressures over 30 psi or RPM of 1200 max. require constant circulation to prevent overheating.

The seal box is designed for the compressed seal length and does not require any adjustments. The seal housing is extra large to provide excellent circulation of clear sealing liquid. The housing also has two tapped openings 180° apart for the flushing connections.

The standard shaft sleeve design is provided with a snap ring which allows the sleeve and the completely assembled seal box to be removed intact. Reassembly can be accomplished in the same manner. Assemble the complete seal box at the convenience of the work bench and install.

SLEEVES

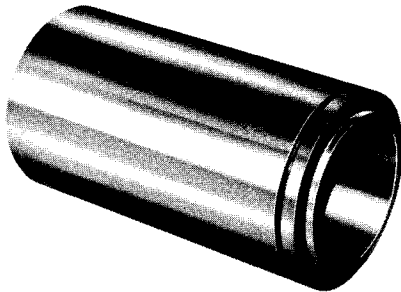

Shaft sleeves, machined to close tolerances are optionally available in either bronze, 316 stainless steel, or monel.

SHAFTS

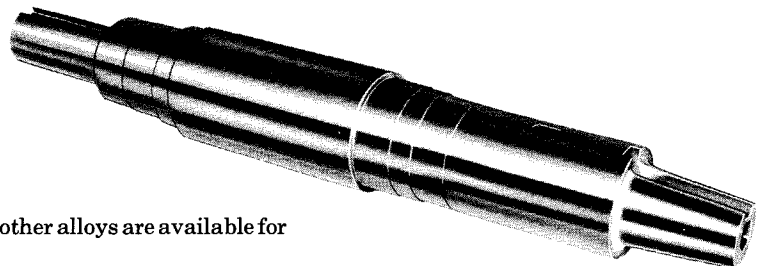

Precision machined shafts of stainless steel, monel and other alloys are available for difficult application.