



AURORA®

PUMP SIZE	RPM			
	1750	1150	875	700
3x3x7	3C	3C		
4x4x7	3C	3C		
3x3x9	3C	3C		
4x4x9A	3C	3C	3C	
4x4x9B	4C	4C	4C	4C
4x4x12	5E	4C	4C	4C
4x6x15	5F	5E	5E	5E

650A SERIES HORIZONTAL AND VERTICAL ONE STAGE SOLIDS HANDLING PUMPS

REPAIR PARTS INDEX

NOTE! Read and understand the pump and motor instructions before attempting to install, disassemble or repair the pump.

650A SERIES
MODEL 651A PF 3C
PIECE NUMBERS

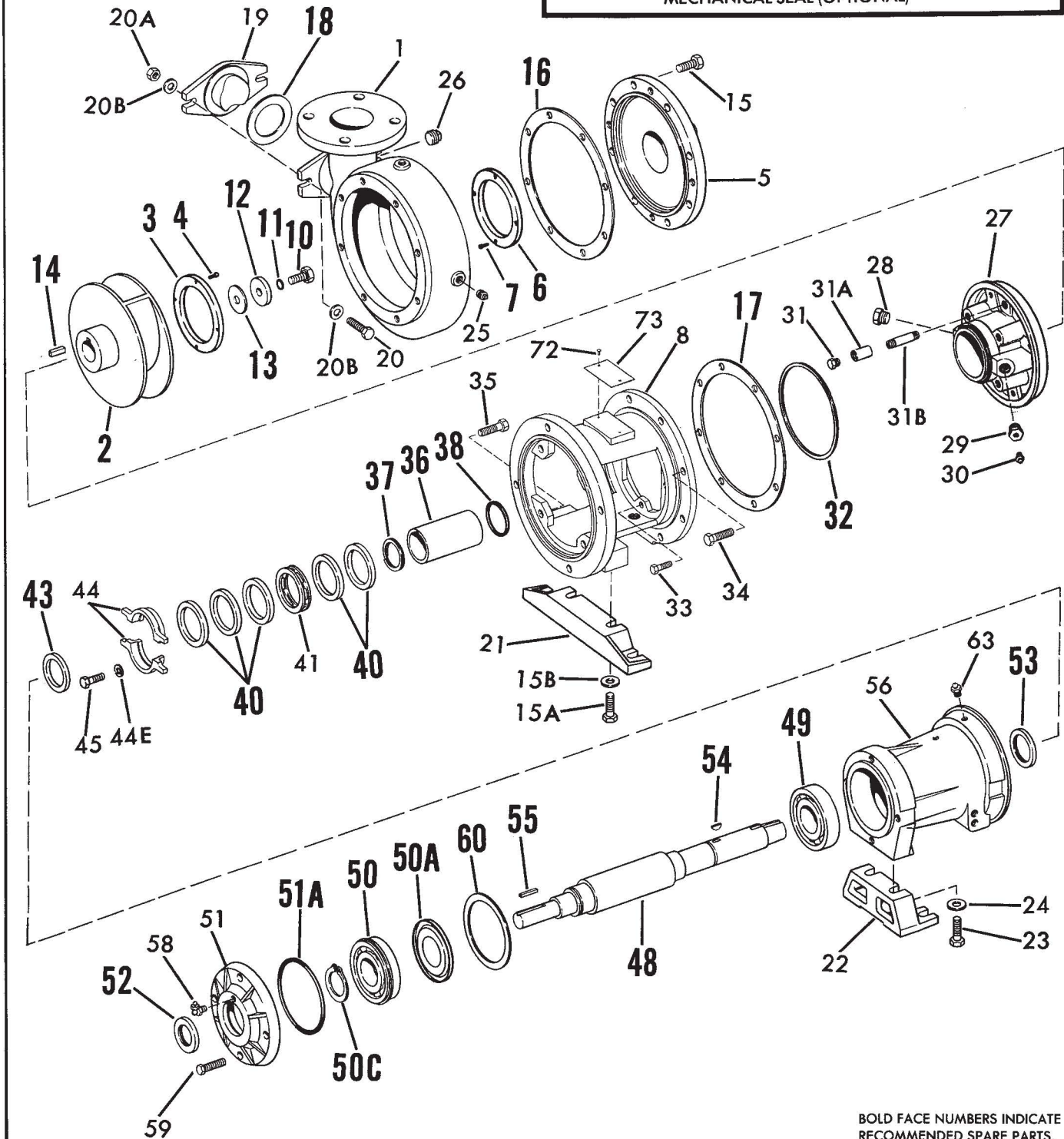
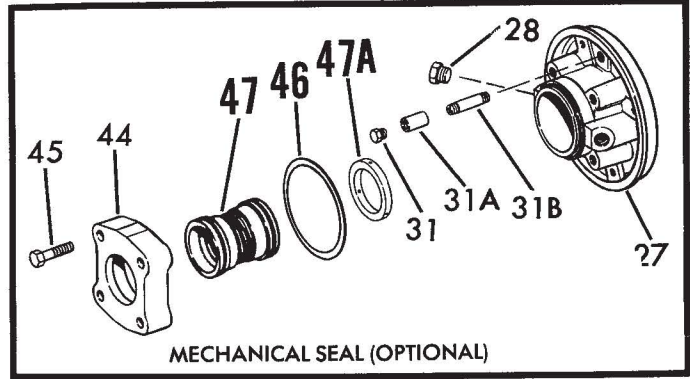

650A SERIES
MODEL 651A PF4 & 5
PIECE NUMBERS

SECTION 650P PAGE 3
 DATED OCTOBER 1993
 SUPERSEDES PAGE 3
 DATED NOVEMBER 1988

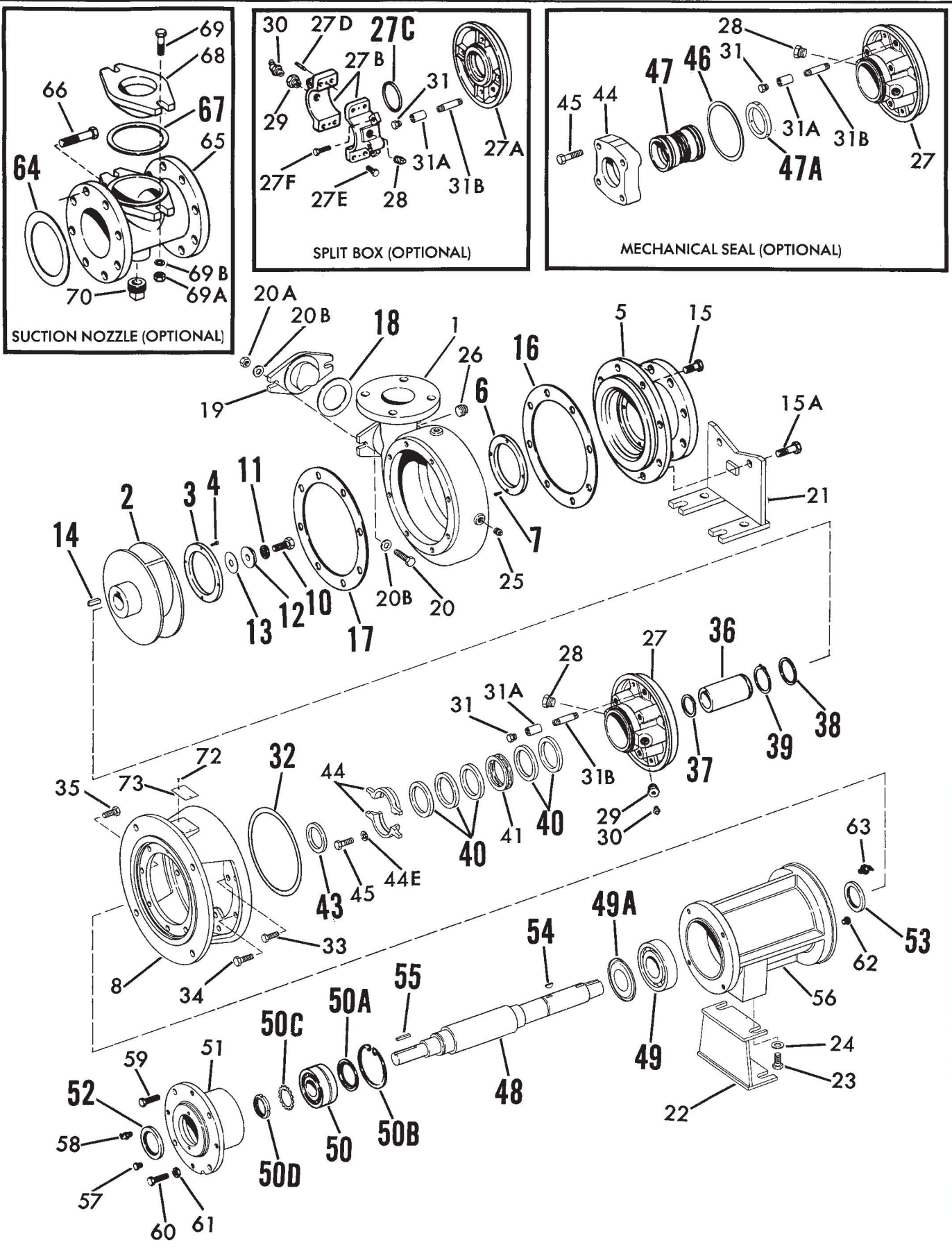

SUCTION NOZZLE (OPTIONAL)

SPLIT BOX (OPTIONAL)

MECHANICAL SEAL (OPTIONAL)

BOLD FACE NUMBERS INDICATE
 RECOMMENDED SPARE PARTS.

650A SERIES
MODEL 652A-653A PF 3C
PIECE NUMBERS

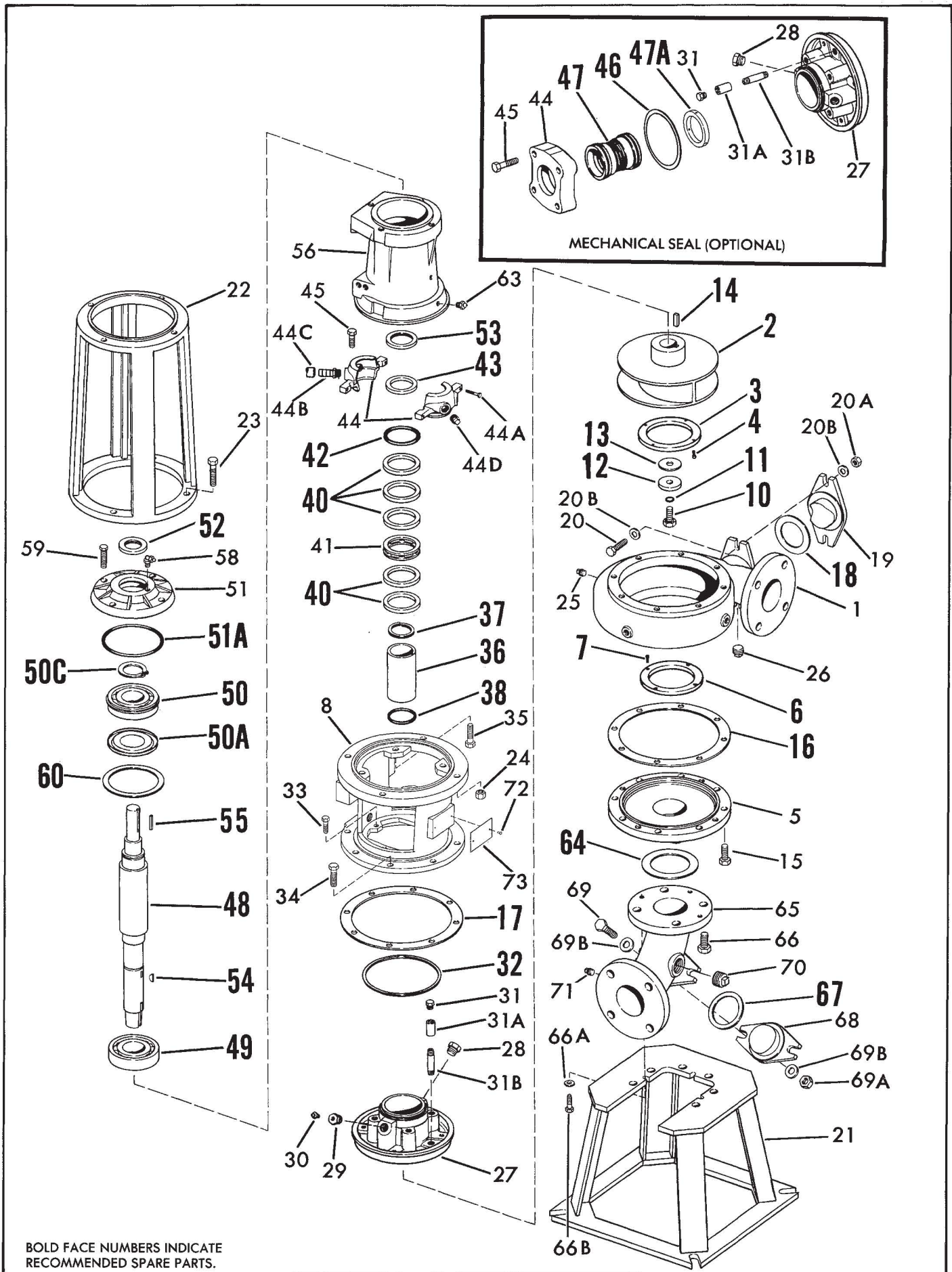

BOLD FACE NUMBERS INDICATE
RECOMMENDED SPARE PARTS.

650A SERIES
MODEL 652A-653A PF 4 & 5
PIECE NUMBERS

SECTION 650P PAGE 5
 DATED OCTOBER 1993
 SUPERSEDES PAGE 5
 DATED NOVEMBER 1988

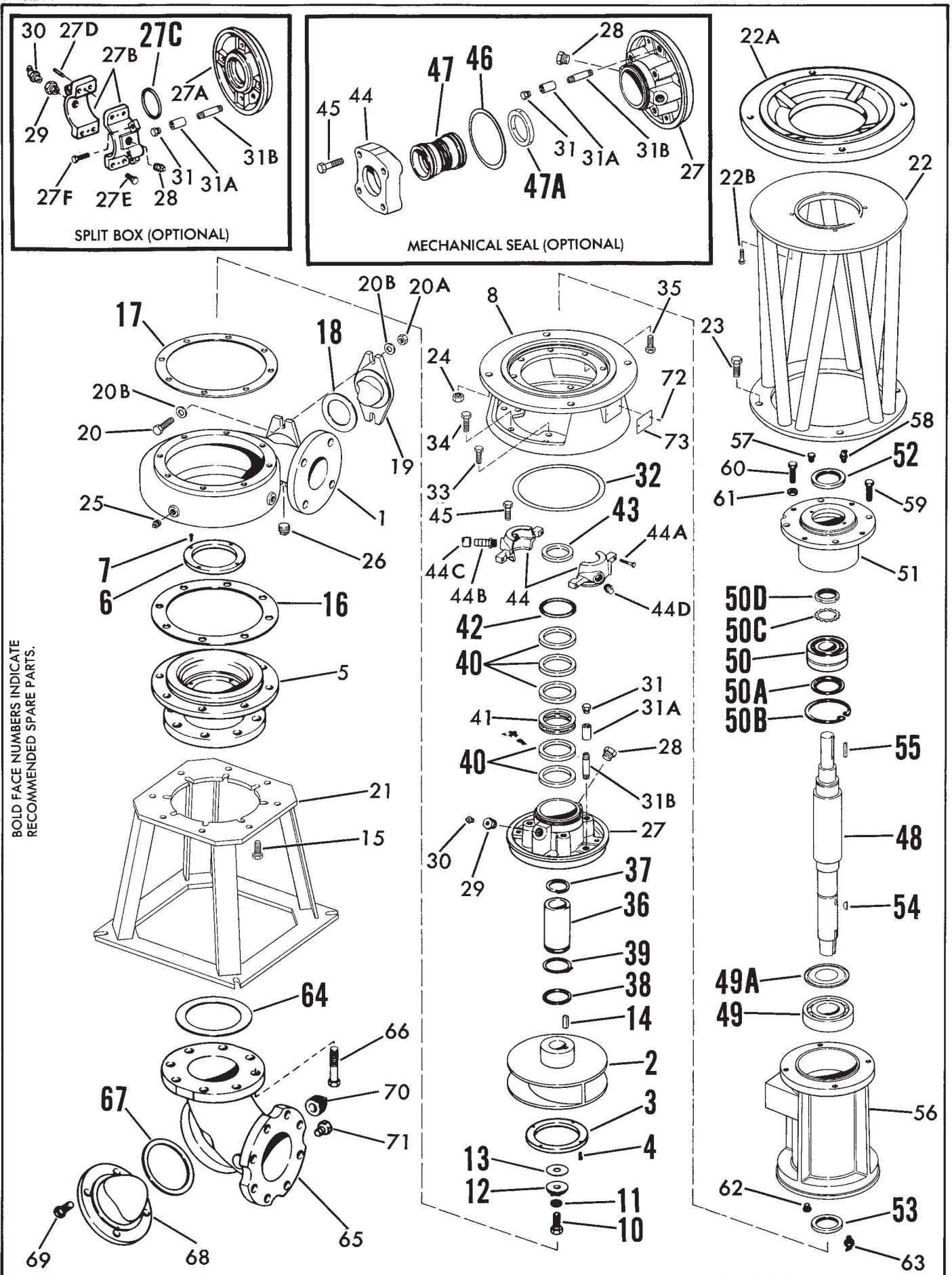

BOLD FACE NUMBERS INDICATE
 RECOMMENDED SPARE PARTS.

SPLIT BOX (OPTIONAL)

MECHANICAL SEAL (OPTIONAL)

- 50D
- 50C
- 50
- 50A
- 50B

650A SERIES
MODEL 654A
PIECE NUMBERS

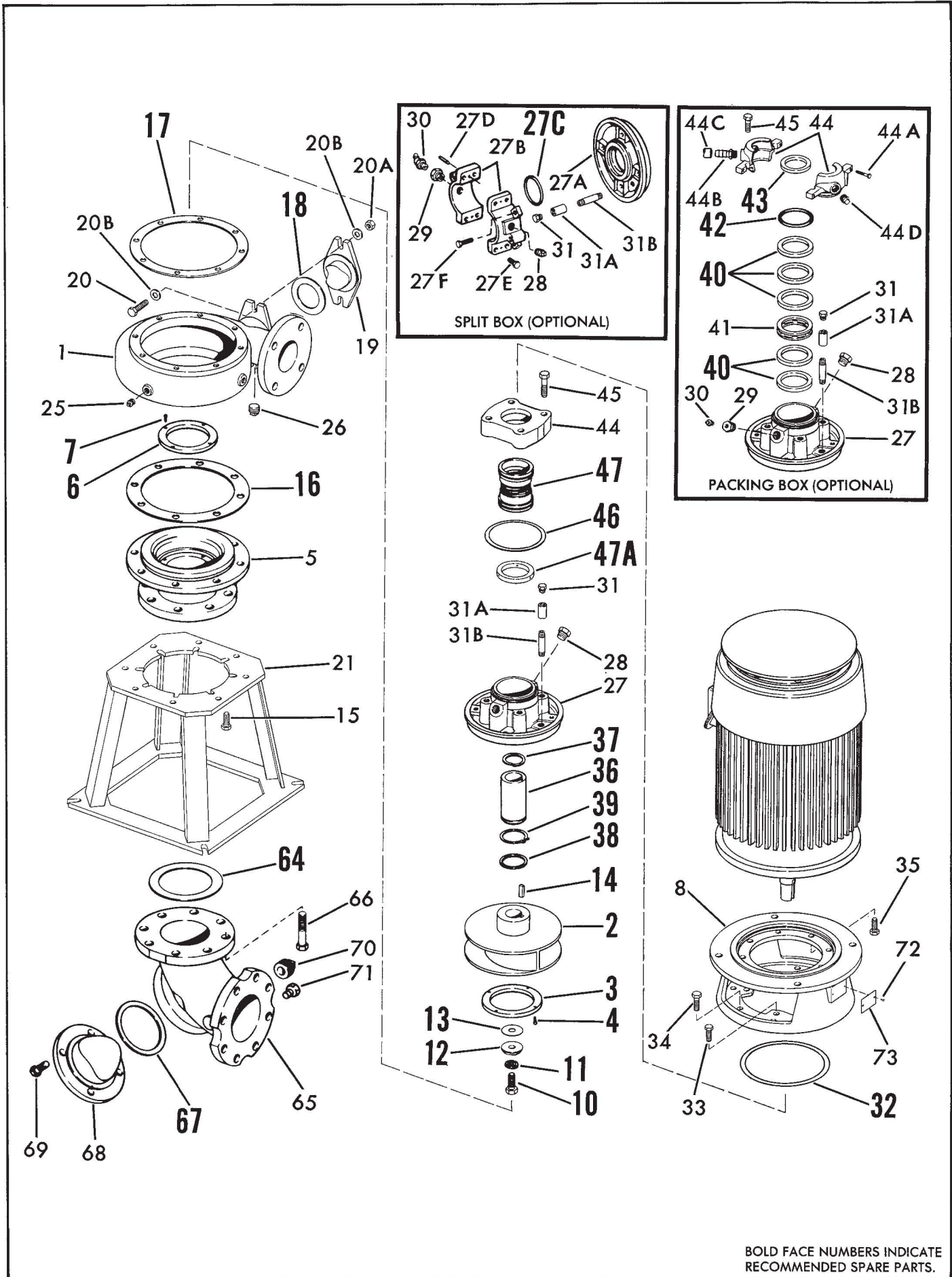

650A SERIES

SECTION 650P PAGE 7
DATED OCTOBER 1993
SUPERSEDES PAGE 7
DATED NOVEMBER 1988

PARTS LIST

PC. NO.	DESCRIPTION	QTY	PART NO.	MATERIAL				PC. NO.	DESCRIPTION	QTY	PART NO.	MATERIAL						
				B.F.	A.B.	A.I.	S.S.					B.F.	A.B.	A.I.	S.S.			
1	CASING							4	SETScrew									
	3x3x7	1	180-2405	010					3x3x7	4	708-0061	104						
	4x4x7	1	180-2398	010					4x4x7	4	708-0067	104						
	3x3x9	1	180-0632	010					3x3x9	4	168-0010	104						
	4x4x9A	1	180-2399	010					4x4x9A	4	708-0067	104						
	4x4x9B	1	180-2400	010					4x4x9B	4	168-0217	104						
	4x4x12	1	180-2401	010					4x4x12 PF 4	4	168-0217	104						
	4x4x15	1	180-2402	010					4x4x12 PF 5	4	168-0217	104						
	4x6x15	1	180-2402	010					4x6x15	4	168-0045	104						
CASING WITH IMP. & WEARING RINGS			CASE															
	3x3x7	1	180-2406	010														
2	IMPELLER							5	SUCTION COVER									
	3x3x7	1	443-2515	010					3x3x7		NOT REQUIRED							
	4x4x7	1	443-2487	010					4x4x7	1	816-1236	010						
	3x3x9	1	443-2549	010					3x3x9	1	816-0695	010						
	4x4x9A	1	443-2489	010					4x4x9A	1	816-1239	010						
	4x4x9B	1	443-2491	010					4x4x9B	1	816-1242	010						
	4x4x12 PF 4	1	443-2497	010					4x4x12	1	816-1245	010						
	4x4x12 PF 5	1	443-2493	010					4x4x12	1	816-1245	010						
	4x6x15	1	443-2495	010					4x6x15	1	816-1248	010						
	IMPELLER WITH WEARING RING								SUCTION COVER WITH IMP. RING									
		3x3x7	1	443-2517	644		646		3x3x7		NOT REQUIRED							
		4x4x7	1	443-2488	644		646		4x4x7	1	816-1237	010						
		3x3x9	1	443-2550	644		646		3x3x9		NOT AVAILABLE							
		4x4x9A	1	443-2490	644		646		4x4x9A	1	816-1240	010						
		4x4x9B	1	443-2492	644		646		4x4x9B	1	816-1243	010						
		4x4x12, PF 4	1	443-2498	644		646		4x4x12	1	816-1246	010						
		4x4x12, PF 5	1	443-2494	644		646		4x4x12	1	816-1246	010						
	4x6x15	1	443-2496	644		646		4x6x15	1	816-1249	010							
3	IMPELLER WEARING RING																	
	3x3x7	1	676-1949	208		108												
	4x4x7	1	676-2065	208		108												
	3x3x9	1	676-1292	208		108												
	4x4x9A	1	676-2065	208		108												
	4x4x9B	1	676-2064	208		108												
	4x4x12, PF 4	1	676-2064	208		108												
	4x4x12, PF 5	1	676-2064	208		108												
	4x6x15	1	676-1918	208		108												
	4	SUCTION COVER																
3x3x7																		
4x4x7		1	816-1236	010														
3x3x9		1	816-0695	010														
4x4x9A		1	816-1239	010														
4x4x9B		1	816-1242	010														
4x4x12		1	816-1245	010														
4x6x15		1	816-1248	010														
SUCTION COVER WITH IMP. RING																		
		3x3x7																
	4x4x7	1	816-1237	010														
	3x3x9																	
	4x4x9A	1	816-1240	010														
	4x4x9B	1	816-1243	010														
	4x4x12	1	816-1246	010														
	4x6x15	1	816-1249	010														
5	SUCTION COVER WITH IMP. RING AND CASE RING																	
	3x3x7																	
	4x4x7	1	816-1238	644		646												
	3x3x9	1	816-0501	644		646												
	4x4x9A	1	816-1241	644		646												
	4x4x9B	1	816-1244	644		646												
	4x4x12	1	816-1247	644		646												
	4x6x15	1	816-1250	644		646												
	SUCTION COVER WITH IMP. RING AND CASE RING																	
		3x3x7																
	4x4x7	1	816-1238	644		646												
	3x3x9	1	816-0501	644		646												
	4x4x9A	1	816-1241	644		646												
	4x4x9B	1	816-1244	644		646												
	4x4x12	1	816-1247	644		646												
	4x6x15	1	816-1250	644		646												
6	SUCTION COVER WEARING RING																	
	3x3x7	1	676-1950	208		108												
	4x4x7	1	676-2065	208		108												

* HARDENED STAINLESS STEEL WEARING RING OPTION

650A SERIES

PARTS LIST

PC. NO.	DESCRIPTION	QTY	PART NO.	MATERIAL				PC. NO.	DESCRIPTION	QTY	PART NO.	MATERIAL			
				B.F.	A.B.	A.I.	S.S.					B.F.	A.B.	A.I.	S.S.
6	SUCTION COVER							14	IMPELLER KEY						
	WEARING RING									PF 3C & 4C	1	472-0250	087		
	(CONT'D)							PF 5E & 5F	1	472-0391	087				
	3x3x9	1	676-1260	208		108	15	CAPSCREW 651A							
	4x4x9A	1	676-2065	208		108		3x3x7		NOT REQUIRED					
	4x4x9B	1	676-2064	208		108		4x4x7	8	168-0382	082				
4x4x12	1	676-2064	208		108	3x3x9		8	168-0489	082					
4x6x15	1	676-1918	208		108	4x4x9A		8	168-0488	082					
7	SETSCREW							4x4x9B	6	168-0560	082				
	3x3x7	4	708-0061	104			4x4x12	6	168-0560	082					
	4x4x7	4	708-0067	104			4x6x15	6	168-0632	082					
	3x3x9	4	168-0010	104			652A, 653A & 654A								
	4x4x9A	4	708-0067	104			3x3x7		NOT REQUIRED						
	4x4x9B	4	168-0217	104			4x4x7	8	168-0382	082					
	4x4x12	4	168-0217	104			3x3x9	8	168-0489	082					
	4x6x15	4	168-0045	104			4x4x9A	8	168-0488	082					
8	BRACKET							4x4x9B	8	168-0560	082				
	3x3x7	1	116-0486	010			4x4x12	8	168-0560	082					
	4x4x7	1	116-0486	010			4x6x15	8	168-0636	082					
	3x3x9	1	116-0487	010			15A	CAPSCREW 651A							
	4x4x9A	1	116-0487	010			3x3x7	2	168-0488	082					
	4x4x9B	1	116-0489	010			4x4x7	2	168-0488	082					
	4x4x12, PF 4	1	116-0490	010			3x3x9	2	168-0488	082					
	4x4x12, PF 5	1	116-0491	010			4x4x9A	2	168-0488	082					
4x6x15	1	116-0492	010			4x4x9B	2	168-0564	082						
10	IMPELLER SCREW							4x4x12	2	168-0564	082				
	PF 3C & 4C	1	168-1008	082			4x6x15	2	168-0636	082					
	PF 5E & 5F	1	168-1009	082			15B	WASHER 651A							
11	IMP SCREW SEAL							3x3x7	2	908-0114	080				
	PF 3C & 4C	1	908-1283	999			4x4x7	2	908-0114	080					
	PF 5E & 5F	1	908-1284	999			3x3x9	2	908-0114	080					
12	IMPELLER WASHER							4x4x9A	2	908-0114	080				
	PF 3C	1	908-0605	087			16	GASKET							
	PF 4C	1	908-0457	062				3x3x7		NOT REQUIRED					
PF 5E & 5F	1	908-0458	062			4x4x7		1	364-1014	603					
13	IMPELLER							9&9A CASE BORE	1	364-1015	603				
	WASHER GASKET							9B CASE BORE	1	364-1324	803				
	PF 3C	1	364-2038	803				12" CASE BORE	1	364-1326	803				
	PF 4C	1	364-2025	803				15" CASE BORE	1	364-1327	803				
	PF 5E & 5F	1	364-2029	803											

* HARDENED STAINLESS STEEL WEARING RING OPTION

650A SERIES

SECTION 650P PAGE 9
DATED OCTOBER 1993
SUPERSEDES PAGE 9
DATED NOVEMBER 1988

PARTS LIST

PC NO.	DESCRIPTION	QTY	PART NO.	MATERIAL				PC NO.	DESCRIPTION	QTY	PART NO.	MATERIAL				
				B.F.	A.B.	A.I.	S.S.					B.F.	A.B.	A.I.	S.S.	
17	GASKET *							21	PUMP BASE							
	7" CASE BORE	1	364-1014	603					652A,653A & 654A							
	9&9A CASE BORE	1	364-1015	603					7" CASE BORE	1	060-1387	087				
	9B CASE BORE	1	364-1324	803					9 & 9A CASE BORE	1	060-1387	087				
	12" CASE BORE	1	364-1326	803					9B CASE BORE	1	060-1387	087				
	15" CASE BORE	1	364-1327	803				12" CASE BORE	1	060-1387	087					
18	GASKET							22	PUMP SUPPORT							
	3x3x7	1	364-1041	453					REAR FOOT 651A							
	4x4x7	1	364-1041	453					7" CASE BORE	1	820-0188	010				
	3x3x9	1	364-1041	453					9 & 9A CASE BORE	1	820-0188	010				
	4x4x9A	1	364-1041	453					9B CASE BORE	1	820-1624	087				
	4x4x9B	1	364-1320	457					12"CASE BORE PF4	1	820-1628	087				
	4x4x12	1	364-1320	457					12"CASE BORE PF5	1	820-1629	087				
4x6x15	1	364-1320	457				15" CASE BORE	1	820-1625	087						
19	HANDHOLE COVER							22A	MOTOR SUPPORT							
	3x3x7	1	260-0098	010					653A							
	4x4x7	1	260-0735	010					PF 3 & 4	1	820-1397	010				
	3x3x9	1	260-0101	010					≤ 284 HPH PF 5	1	820-1617	087				
	4x4x9A	1	260-0736	010					≥ 284 HPH PF 5	1	820-1620	087				
	4x4x9B	1	260-0737	010					ADAPTOR 653A							
	4x4x12	1	260-0738	010					≥ 284 HPH PF 3&4	1	008-0340	010				
4x6x15	1	260-0738	010													
20	CAPSCREW							22B	CAPSCREW 653A							
	3x3x7	2	168-0388	082					≥ 284 HPH PF 3&4	1	168-0562	082				
	4x4x7	2	168-0382	082												
	3x3x9	2	168-0388	082					23	CAPSCREW						
	4x4x9A	2	168-0382	082					REAR FOOT 651A							
	4x4x9B	2	168-0562	082					PF 3C	2	168-0490	082				
	4x4x12	2	168-0562	082					PF 4C	2	168-0560	082				
4x6x15	2	168-0562	082				PF 5E & 5F	2	168-0668	082						
20A	NUT 3x3x7	2	544-0109	080				CAPSCREW 653A								
	3x3x9	2	544-0109	080				PF 3C & 4C	4	168-0494	082					
20B	WASHER 3x3x7	4	908-0112	080				PF 5E & 5F	4	168-0640	082					
	3x3x9	4	908-0112	080												
21	PUMP SUPPORT FRONT FOOT 651A							24	WASHER							
	7" CASE BORE	1	820-0186	010					REAR FOOT 651A							
	9 & 9A CASE BORE	1	820-0186	010					PF 3C	2	908-0114	080				
	9B CASE BORE	1	820-0509	087					PF 4C	2	908-0116	080				
	12" CASE BORE	1	820-0507	087					PF 5E & 5F	2	908-0118	080				
	15" CASE BORE	1	820-0505	087				NUT 653A								
								PF 3C & 4C	4	544-0113	080					
								PF 5E & 5F	4	544-0117	080					

*FOR MODEL 654A REFER TO FACTORY FOR SHIM GASKETS.

< = LESS THAN ≥ = GREATER THAN OR EQUAL TO

650A SERIES

SECTION **650P** PAGE **11**
 DATED OCTOBER 1993
 SUPERSÉDES PAGE 11
 DATED NOVEMBER 1988

PARTS LIST

PC. NO.	DESCRIPTION	QTY	PART NO.	MATERIAL				PC. NO.	DESCRIPTION	QTY	PART NO.	MATERIAL			
				B.F.	A.B.	A.I.	S.S.					B.F.	A.B.	A.I.	S.S.
36	SLEEVE (CONT'D)							44	GLAND (CONT'D)						
	MECHANICAL SEALS								MECHANICAL SEAL						
	PF 3 & 4	1	756-0411	208					GLAND FOR						
	PF 5	1	756-0412	208					JOHN CRANE						
37	RETAINING RING							TYPE 1,21,8TD							
	PF 3 & 4	1	676-0470	088				PF 3 & 4	1	372-0518	010				
	PF 5	1	676-0471	088				PF 5	1	372-0520	010				
38	GASKET							JOHN CRANE							
	PF 3 & 4	1	364-0581	457				TYPE 8B2							
	PF 5	1	364-0584	457				PF 3 & 4	1	372-0519	104				
39	RETAINING RING							PF 5	1	372-0521	104				
	PF 3		NOT REQUIRED					DURAMETALLIC							
	PF 4	1	676-0294	088				TYPE CRO, BRO							
	PF 5	1	676-0460	088				PF 3 & 4	1	372-0524	010				
40	PACKING							PF 5	1	372-0520	010				
	PF 3 & 4	5	564-0114	802				DURAMETALLIC							
	PF 5	5	564-0183	802				TYPE RA							
41	LANTERN RING							PF 3 & 4	1	372-0525	104				
	PF 3 & 4	1	676-1105	512				PF 5	1	372-0527	104				
	PF 5	1	676-1106	512				CHESTERTON							
42	O-RING (PACK)							TYPE 880							
	PF 3 & 4	1	364-0425	457				PF 3 & 4	1	372-0530	104				
	PF 5	1	364-2101	457				PF 5	1	372-0531	104				
43	SLINGER (PACK)							44A	CAPSCREW (PACK)	2	168-0718	080			
	PF 3 & 4	1	764-0021	478				44B	HOSE CONNECTOR						
	PF 5	1	764-0023	478				(PACK) PF 3,4&5	1	600-2966	503				
	MECHANICAL SEALS							44C	HOSE (PACK)	1	872-0005	505			
44	SLINGER							44D	PIPE PLUG (PACK)	3	600-0004	511			
	PF 3 & 4	1	764-0020	478				44E	GLAND CLAMP						
	PF 5	1	764-0022	478				651A (PACK)							
	GLAND							PF 3 & 4	2	204-0116	360				
44	651A PACK							PF 5	2	204-0121	360				
	PF 3 & 4	1	372-0320	010				45	CAPSCREW						
	PF 5	1	372-0321	010				651A PACKING	2	168-0500	082				
	652A & 653A PACK							652A & 653A							
	PF 3 & 4	1	372-0515	319				PACKING	2	168-0502	082				
	PF 5	1	372-0516	319				MECH. SEAL SCREWS	REFER TO	FACTORY					
46	GASKET (SEAL)							46	GASKET (SEAL)						
	PF 3 & 4	1	364-0074	803				PF 3 & 4	1	364-0074	803				
	PF 5	1	364-0075	803				PF 5	1	364-0075	803				

PARTS LIST

PC. NO.	DESCRIPTION	QTY	PART NO.	MATERIAL				PC. NO.	DESCRIPTION	QTY	PART NO.	MATERIAL					
				B.F.	A.B.	A.I.	S.S.					B.F.	A.B.	A.I.	S.S.		
47	MECHANICAL SEAL							50	BEARING OUTBOARD								
	POWER FRAME 3&4								PF 3C	1	068-2560	647					
	J.C. 21 DBL.	1	712-6410	753					PF 4C	1	068-3004	647					
	J.C. 8TD DBL.	1	712-6411	753					PF 5E	2	068-2996	647					
	J.C. 88 CART.	1	712-6413	767					PF 5F	2	068-2996	647					
	* J.C. 1 SINGLE	1	712-6409	678													
	J.C. 8B2 OUT.	1	712-6412	678													
	DURA CRO DBL.	1	712-6424	772													
	DURA X200 CART.	1	712-6431	519													
	DURA RA OUT.	1	712-6425	566													
	CHEST. 241 CART.	1	712-6433	571													
	CHEST. 880 SINGLE	1	712-6435	571													
	POWER FRAME 5																
	J.C. 1 DBL.	1	712-6415	753													
	J.C. 8TD DBL.	7	712-6416	753													
	J.C. 88 CART.	1	712-6418	767													
	* J.C. 1 SINGLE	1	712-6414	678													
	J.C. 882 OUT.	1	712-6417	678													
	DURA CRO DBL.	1	712-6426	773													
	DURA BRO DBL.	1	712-6427	741													
DURA RA OUT.	1	712-6428	566														
CHEST. 241 CART.	1	712-6434	571														
CHEST. 880 SINGLE	1	712-6436	571														
47A	BUSHING							50A	GREASE SHIELD								
	FOR SINGLE SEALS								PF 3C	1	712-0283	087					
	PF 3 & 4	1	224-0223	208					PF 4C	1	676-0560	087					
	PF 5	1	224-0224	208				PF 5E & 5F	1	676-0398	010						
48	SHAFT							50B	RETAINING RING								
	PF 3C	1	728-0513	063					PF 3C	1	INCLUDED	WITH PC. 50					
	PF 4C	1	728-0514	063					PF 4C	1	676-0446	088					
	PF 5E & 5F	1	728-0515	063					PF 5E & 5F	1	676-0447	088					
49	BEARING INBOARD							50C	RETAINING RING								
	PF 3C	1	068-0427	647					PF 3C	1	676-0944	088					
	PF 4C	1	068-0162	647					PF 4C	1	676-0943	088					
	PF 5E	1	068-0168	647					LOCK WASHER								
	PF 5F	1	068-0046	647				PF 5E & 5F	1	908-0416	080						
49A	GREASE SHIELD							50D	LOCKNUT PF 5	1	544-0716	080					
	PF 4C	1	712-0280	087													
	PF 5E & 5F	1	712-0281	087													
								51	BEARING CARTRIDGE								
									PF 3C	1	164-0472	010					
									PF 4C	1	164-0447	010					
									PF 5E & 5F	1	164-0448	010					
								51A	O-RING PF 3C	1	364-0570	457					
								52	GREASE SEAL								
									PF 3C	1	712-0233	653					
									PF 4C	1	712-0248	653					
									PF 5E & 5F	1	712-0241	653					
								53	GREASE SEAL								
									PF 3C	1	712-0234	653					
									PF 4C	1	712-0240	653					
									PF 5E & 5F	1	712-0265	653					
								54	KEY, SLEEVE	1	472-0010	087					
								55	KEY, SHAFT								
									PF 3C	1	472-0247	087					
									PF 4C	1	472-0250	087					
									PF 5E & 5F	1	472-0390	087					

* REFER TO FACTORY FOR J.C. 1 SINGLE SEALS, COLLARS AND SETSCREWS.

650A SERIES

SECTION 650P PAGE 13
DATED OCTOBER 1993
SUPERSEDES PAGE 13
DATED NOVEMBER 1988

PARTS LIST

PC NO.	DESCRIPTION	QTY	PART NO.	MATERIAL				PC NO.	DESCRIPTION	QTY	PART NO.	MATERIAL			
				B.F.	A.B.	A.I.	S.S.					B.F.	A.B.	A.I.	S.S.
56	POWER FRAME HOUSING							65	ELBOWS (CONT'D)						
	PF 3C	1	356-0203	010					(STD) 4x4	1	600-4533	010			
	PF 4C	1	356-0044	010					(CLEANOUT) 4x4	1	816-1015	010			
	PF 5E & 5F	1	356-0045	010				4x6	1	816-0740	010				
57	PIPE PLUG							STD.W/CLEANOUT							
	PF 3C		NOT REQUIRED						6x6	1	816-1018	010			
	PF 4C	1	600-0001	087					6x8	1	816-1019	010			
	PF 5E & 5F	1	600-0001	087											
58	GREASE FITTING							66	CAPSCREW						
	PF 3C	1	508-0005	651					3" SUCTION	4	168-0562	082			
	PF 4C	1	508-0015	651					4" SUCTION	2	168-0564	082			
	PF 5E & 5F	1	508-0010	651					4" SUCTION	6	168-0570	082			
								6" SUCTION	8	168-0636	082				
59	CAPSCREWS							66A	WASHER						
	PF 3C	4	168-0492	082					3" SUCTION	3	908-0112	080			
	PF 4C	3	168-0492	082											
	PF 5E & 5F	4	168-0564	082				66B	CAPSCREW						
60	SHIM PACK							67	GASKET 3x3	1	364-1041	453			
	PF 3C	1	740-0070	517					3x4	1	364-1042	453			
	CAPSCREWS PF 4C	3	168-0201	080					4x4	1	364-1043	453			
	PF 5E & 5F	4	168-0202	080					4x6	1	364-1043	453			
61	JAM NUT							68	6x6	1	364-1048	478			
	PF 3C		NOT REQUIRED						6x8	1	364-1048	478			
	PF 4C	3	544-0312	080					HANDHOLE COVER						
	PF 5E & 5F	4	544-0316	080				3x3	1	260-0093	010				
62	PIPE PLUG							68	3x4	1	260-0089	010			
	PF 3C		NOT REQUIRED						4x4	1	260-0088	010			
	PF 4C	1	600-0001	087					4x6	1	260-0088	010			
	PF 5E & 5F	1	600-0001	087					6x6	1	260-0649	010			
63	GREASE FITTING							69	6x8	1	260-0649	010			
	PF 3C	1	508-0001	651					CAPSCREW						
	PF 4C	1	508-0015	651					3x3	2	168-0494	082			
	PF 5E & 5F	1	508-0010	651				3x4	2	168-0494	082				
64	GASKET 652A, 653A & 654A							69A	4x4	2	168-0564	082			
	3" SUCTION	1	364-0605	603					4x6	2	168-0564	082			
	4" SUCTION	1	364-0607	603					6x6	4	168-0562	082			
	6" SUCTION	1	364-0609	603					6x8	4	168-0562	082			
65	ELBOWS 652A, 653A & 654A							69A	NUT						
	(STD) 3x3	1	600-4581	010					3x3	2	544-0113	080			
	(CLEANOUT) 3x3	1	816-0739	010					3x4	2	544-0113	080			
	3x4	1	816-0742	010					4x4	2	544-0115	080			
								4x6	2	544-0115	080				

THIS PAGE INTENTIONALLY LEFT BLANK

WARRANTY

Seller warrants equipment (and its component parts) of its own manufacture against defects in materials and workmanship under normal use and service for one (1) year from the date of installation or start-up, or for eighteen (18) months after the date of shipment, whichever occurs first. Seller does not warrant accessories or components that are not manufactured by Seller; however, to the extent possible, Seller agrees to assign to Buyer its rights under the original manufacturer's warranty, without recourse to Seller. Buyer must give Seller notice in writing of any alleged defect covered by this warranty (together with all identifying details, including the serial number, the type of equipment, and the date of purchase) within thirty (30) days of the discovery of such defect during the warranty period. No claim made more than 30 days after the expiration of the warranty period shall be valid. Guarantees of performance and warranties are based on the use of original equipment manufactured (OEM) replacement parts. Seller assumes no responsibility or liability if alterations, non-authorized design modifications and/or non-OEM replacement parts are incorporated. If requested by Seller, any equipment (or its component parts) must be promptly returned to Seller prior to any attempted repair, or sent to an authorized service station designated by Seller, and Buyer shall prepay all shipping expenses. Seller shall not be liable for any loss or damage to goods in transit, nor will any warranty claim be valid unless the returned goods are received intact and undamaged as a result of shipment. Repaired or replaced material returned to customer will be shipped F.O.B., Seller's factory. Seller will not give Buyer credit for parts or equipment returned to Seller, and will not accept delivery of any such parts or equipment, unless Buyer has obtained Seller's approval in writing. The warranty extends to repaired or replaced parts of Seller's manufacture for ninety (90) days or for the remainder of the original warranty period applicable to the equipment or parts being repaired or replaced, whichever is greater. This warranty applies to the repaired or replaced part and is not extended to the product or any other component of the product being repaired. Repair parts of its own manufacture sold after the original warranty period are warranted for a period of one (1) year from shipment against defects in materials and workmanship under normal use and service. This warranty applies to the replacement part only and is not extended to the product or any other component of the product being repaired. Seller may substitute new equipment or improve part(s) of any equipment judged defective without further liability. All repairs or services performed by Seller, which are not covered by this warranty, will be charged in accordance with Seller's standard prices then in effect.

THIS WARRANTY IS THE SOLE WARRANTY OF SELLER AND SELLER HEREBY EXPRESSLY DISCLAIMS AND BUYER WAIVES ALL OTHER WARRANTIES EXPRESSED, IMPLIED IN LAW OR IMPLIED IN FACT, INCLUDING ANY WARRANTIES OF MERCHANTABILITY OR FITNESS FOR A PARTICULAR PURPOSE. Seller's sole obligation under this warranty shall be, at its option, to repair or replace any equipment (or its component parts) which has a defect covered by this warranty, or to refund the purchase price of such equipment or part. Under the terms of this warranty, Seller shall not be liable for (a) consequential, collateral, special or liquidated losses or damages; (b) equipment conditions caused by normal wear and tear, abnormal conditions of use, accident, neglect, or misuse of said equipment; (c) the expense of, and loss or damage caused by, repairs or alterations made by anyone other than the Seller; (d) damage caused by abrasive materials, chemicals, scale deposits, corrosion, lightning, improper voltage, mishandling, or other similar conditions; (e) any loss, damage, or expense relating to or resulting from installation, removal or reinstallation of equipment; (f) any labor costs or charges incurred in repairing or replacing defective equipment or parts, including the cost of reinstalling parts that are repaired or replaced by Seller; (g) any expense of shipment of equipment or repaired or replacement parts; or (h) any other loss, damage or expense of any nature.

The above warranty shall not apply to any equipment which may be separately covered by any alternate or special warranties.

PERFORMANCE: In the absence of Certified Pump Performance Tests, equipment performance is not warranted or guaranteed. Performance curves and other information submitted to Buyer are approximate and no warranty or guarantee shall be deemed to arise as a result of such submittal. All testing shall be done in accordance with Seller's standard policy under Hydraulic Institute procedures.

LIABILITY LIMITATIONS: Under no circumstances shall the Seller have any liability under the Order or otherwise for liquidated damages or for collateral, consequential or special damages or for loss of profits, or for actual losses or for loss of production or progress of construction, regardless of the cause of such damages or losses. In any event, Seller's aggregate total liability under the Order or otherwise shall not exceed the contract price.

ACTS OF GOD: Seller shall in no event be liable for delays in delivery of the equipment or other failures to perform caused by fires, acts of God, strikes, labor difficulties, acts of governmental or military authorities, delays in transportation or procuring materials, or causes of any kind beyond Seller's control.

COMPLIANCE WITH LAW: Seller agrees to comply with all United States laws and regulations applicable to the manufacturing of the subject equipment. Such compliance shall include: The Fair Labor Standards Acts of 1938, as amended; Equal Employment Opportunity clauses of Executive Order 11246, as amended; Occupational Safety and Health Act of 1970 and the standards promulgated thereunder, if applicable. Since compliance with the various Federal, State, and Local laws and regulations concerning occupational health and safety, pollution or local codes are affected by the use, installation and operation of the equipment and other matters over which Seller has no control, Seller assumes no responsibility for compliance with those laws and regulations, whether by way of indemnity, warranty, or otherwise. It is incumbent upon the Buyer to specify equipment which complies with local codes and ordinances.



AURORA®

800 Airport Road
North Aurora, Illinois 60542
630-859-7000
www.aurorapump.com