



## Irrigation handbook

BE > THINK > INNOVATE >

GRUNDFOS® 



# Index

<b>Introduction</b>	<b>4</b>
<b>1. Irrigation methods</b>	<b>6</b>
1.1 Flooding	7
1.2 Sprinkling	8
1.2.1 Fixed sprinklers	8
1.2.2 Travelling irrigators	9
1.2.2.1 Hose reel irrigator	9
1.2.2.2 Centre pivot irrigator	9
1.2.2.3 Parallel irrigators	10
<b>2. Availability of water</b>	<b>12</b>
2.1 Ground water	13
2.1.1 Supply limitations	13
2.1.2 Ground water troubleshooting	15
2.1.3 Pump wear	16
2.1.4 Clogging	18
2.1.5 Overpumping	19
2.2 Surface water	20
2.2.1 Intake structure design	20
2.2.1.1 Settling canal	21
2.2.2 Overcoming dry seasons and droughts	22
2.2.2.1 Riverbank injection	22
2.2.2.2 Lowering of water level by others (public water supply)	22
2.2.3 Destruction of equipment from flooding	23
2.2.4 Theft risk (drawing from public areas)	23
2.3 Rain & water NEWater	24
2.3.1 Rain water harvesting	24
2.3.1.1 Source capacity	24
2.3.2 NEWater or water recycling	25
2.3.3 Upgrading low source quality comparison	25
2.4 Storage of water	26
2.4.1 Open-air basin	26
2.4.2 Water tank or underground cavern	27
2.4.3 Parallel operating boosters	27

<b>3. Crops and water</b>	<b>28</b>
3.1 Annual amount of rainfall	29
3.1.1 The need for irrigation	30
3.1.2 Gathering data	31
3.2 Crop water needs	32
3.2.1 The climate	33
3.2.2 The crop type	34
3.2.3 Growth stage	35
3.2.4 Effective rainfall	37
3.3 Other applications	38
3.3.1 Dust control	38
3.3.2 Fire prevention	38
3.3.3 Frost protection	38
<b>4. Irrigation water quality</b>	<b>40</b>
4.1 Bag filtering	41
4.2 Carbonising	41
4.3 Direct fertilisation	41
4.4 Ion exchange	42
4.5 pH adjustment	43
<b>5. Drainage</b>	<b>44</b>
<b>6. Pump catalogue</b>	<b>46</b>
6.1 Factors to consider	47
Grundfos products	
SP / SP A / SP-G	50
SQ / SQ-N / SQE / SQE-N	52
CR / CRI / CRN	54
HS	56
Hydro 2000	58
NB / NK	60
BM / BMB	62
DME / DMS	64
<b>7. About Grundfos</b>	<b>66</b>

# Introduction

Nature, it is often said, is truly amazing. With the right combination of sun, soil, temperature and water, plant life can flourish. Sometimes, however, nature can use a helping hand.

Adding water through irrigation has been practiced for thousands of years. Irrigation can enhance both crop quality and quantity and it can even do so in areas where precipitation already can sustain agriculture. For recreational activities, irrigation keeps playing surfaces lush and attractive.

### **Helping you make more qualified selections**

This handbook presents you with some irrigation basics: from system layouts, to our recommendations for which pumps may be employed in irrigation systems.

It will enable you to make more qualified selections and solutions for your irrigation customers. As always, we recommend consulting Grundfos WinCAPS, our own PC-based pump sizing and selection tool, prior to making your decisions.

### **60 years of experience**

Grundfos' experience with water supply pumps goes all the way back to our earliest years. In fact, a water supply pump was the very first pump we ever created. Today, our product portfolio features submersible, in-line, and pressure boosting pumps for all needs.

### **International presence**

Grundfos is where you are, sharing knowledge of local markets in terms of sales, service, and technical support. Our global operations feature activities in over 40 countries, where remaining in close contact with our customers is one of our most important goals.



# 1. Irrigation methods

When a decision about irrigation of an area has been made, there are also a number of basic considerations to be made. These include:

- Which crops have to be grown
- How is the climatic conditions
- How much water is available
- How accessible is the water
- Is the growth area flat or hilly
- Is the soil clayish or sandy
- How many months per year is it necessary to irrigate
- How is the irrigation pump selected
- The consequences if the irrigation fails for a period of time

These considerations are dealt with in other chapters of this book. The sum of these considerations will support the decision regarding which irrigation method should be used.

First and most importantly, however, you must get a permit from your local authorities! The permit will typically allow a certain amount of water per year to be taken from the resource. This amount must not be exceeded. Your local authorities may use different approaches to monitor the usage, and this may require different types of equipment: flow meter, water meter, hour meter, and so on.

## 1.1 Flooding

The simplest form of irrigation is flooding, and it often requires no pumps. The most common type of flooding is furrow irrigation, where the water is directed or pumped into a number of furrows, which are then flooded.

This method requires landscape sloping technique, where the water can flow easily from one end of the furrow to the other, without spilling over the edges. An equal amount of water as possible should reach each metre of the furrows.

Flooding irrigation requires a lot of water and the efficiency is not very high, since most of the flooded water cannot be extracted into the roots of the plants. It is therefore primarily used in areas where there is plenty of water available. Also, the area to be flooded must of course be relatively flat. Where that is not the case, the areas are flattened into terraces, which can be seen in many areas of the world. Flooding is typically used in tropical areas.



*Flooding is simple, but not very efficient*





## 1.2 Sprinkling

Sprinklers are still dominating agricultural and landscape irrigation worldwide. They are available from lots of different manufacturers, and are used for a variety of applications.

The most common type of sprinkler is the spray head. Spray heads can be fixed, and cover only a certain angle of watering, or it can have a rotating element, which allows it to cover a full circle. Also, the rotating element allows for a bigger variation in drop sizes, distribution, etc. One of the advantages with spray heads is their ability also to distribute small amounts of water. They can be adjusted to deliver only a fine mist of water, however, the wind drift makes their use limited to areas where there is no or little wind. Greenhouses are a good example for the spray head application. This is also an application, where large drops of water may damage the crops, or they will splash dirt on them.

Spray heads feature a radius of approximately 15 m. When they are used in the open land, they should always be used as close to the ground as possible, in order to minimize wind drift. At best they should be installed just above the ground. When used properly the efficiency of spray heads can be quite high.

All spray heads require a minimum pressure to function properly. To maintain an efficient use of the water, it is important to control flow and head within certain narrow limits, and the use of a pump to maintain this makes irrigation much more efficient.



Another widely used sprinkler type is the impact sprinkler. This sprinkler type has a spring loaded inertia element, which is forced to turn by the water jet. The spring makes the inertia element return to the original position, and it hammers on the sprinkler and forces it to turn a certain angle. It can be adjusted to cover almost one full circle of watering. The throw of this type of sprinkler is typically up to 25 m. A very large and special type of impact sprinkler is called rain gun, or end gun, and some of them can distribute more than 100 m<sup>3</sup> per hour in a radius up to 70 m.

### 1.2.1 Fixed sprinklers

These sprinklers are mounted above the ground throughout the season. A certain number of sprinklers per hectare make sure that every square metre of the ground receives a minimum amount of water. This approach requires a lot of sprinklers, and the water is not evenly distributed on the crops.



Fixed sprinklers are typically used on slopes and in hilly areas, where travelling irrigators are restricted. Another typical application for fixed sprinklers is frost protection of crops (see also chapter 3.3) The pop-up sprinkler is a fixed sprinkler variant. These sprinklers are hidden below the surface when not in operation, and rise when in use. The water pressure makes them pop up, following which they function like other sprinklers. This function makes them perfect for irrigation of recreational grass.

### 1.2.2 Travelling irrigators

Sprinklers attached to moving equipment are called travelling irrigators. These mobile units can irrigate a variety of areas.

#### 1.2.2.1 Hose reel irrigator

The most flexible form of a travelling irrigator is the hose reel irrigator that can be hauled into a field, and from there hooked up to the water supply. The hose reel irrigator has only one sprinkler. This is typically a rain gun, which therefore covers a large area.

#### 1.2.2.2 Centre pivot irrigator

A very popular travelling irrigator type for large areas is the centre pivot irrigator. This irrigator rotates around a centre point (pivot) and can have a diameter up to 2 km. Centre pivot irrigators cannot be transferred to another location unless being totally dismantled and transported to the new location.

Centre pivot irrigators are available with one arm (a radius in the circle) or with 2 arms (a diameter in the circle). In order to secure a uniform amount of water per  $m^2$ , this type of irrigator is usually equipped with pressure regulators for each sprinkler, which also vary in size. The longer the distance the sprinkler is located from the centre, the larger the sprinkler and the higher pressure is necessary.

Centre pivot irrigators are built in segments, each segment being typically around 50 m. At the end of each segment are the wheels, which carry the structure, and makes the entire structure move. The irrigators may consist of several segments. The last segment is sometimes not active, but are being pulled after the last but one. When the irrigator is approaching a corner, the last segment becomes active, is swinging out, and is irrigating a corner of the land. A large rain gun mounted at the end of the last segment can further support this function. This functionality makes it possible to more or less cover a square with a centre pivot irrigator and not only the typical circle.





### 1.2.2.3 Parallel irrigators

Parallel irrigators are often of the same mechanical construction as the pivot irrigator, but instead of travelling around a centre, it moves the whole frame parallel from one end of the field to the other. It can irrigate a full rectangle instead of a circle or a 'rounded square', and therefore more efficient to use where the full corner must be irrigated.

It is also easier to establish the parallel irrigator at a different location than a pivot irrigator because it is not dependent on the availability of the special pivot centre.

The disadvantage is that only the centre of the field gets an even amount of water at regular intervals, while towards both ends of the field, more or less double the amount of water is given with a short interval in between. The only ways to compensate for that is to control the amount of water irrigated, or/and to control the speed with which the irrigator moves.

	Radius (m)	Flow (m <sup>3</sup> /h)
Nozzles / spray heads	0.6 - 5.5	0.1 - 1.2
Pop-up sprinklers	4 - 30	>1 - 15
Rotating sprinklers	4 - 35	>1 - 30
Rain guns	30 - 70	30 - 120
Drip irrigation, per dripper		0.001 - 0.025



### **Drip irrigation**

This method (also called micro drip irrigation) is increasing in popularity worldwide, primarily because of its very high water efficiency. By this method no or very little water is lost through evaporation or runoff.

Since there are no moving parts to transport the water, nor water runoff from the surface, drip irrigation is ideal on slopes and in hilly areas.

The disadvantages are that it is costly and time consuming to install.

It also requires a very precise control of the water pressure, adding to the expense of the investment.

## 2. Availability of water

Identifying the characteristics of your water source is vital for the quality of your irrigation. Different water sources must of course be managed differently. The performance of the pump relies heavily on a systematic analysis of the water source, and making the proper selection of equipment based on this data.

## 2.1 Ground water

Ground water provides a significant source of water supplies for irrigation worldwide. It is possibly the most reliable water source we have. However, it is important to use ground water wisely. We must ensure future water supplies and protect the fragile environment in which we live.

Surface water flow is relatively easy to understand, because it is readily observed and easily measured. Ground water flow is however hidden, making measurements more complicated.

The most common restrictions concerning ground water supply are:

- Supply limitations
- Pump wear
- Clogging
- Overpumping

This section presents some solutions to these problems.

### 2.1.1 Supply limitations

Overpumping a well will eventually result in dry running, which can cause in serious damage to the pump. The resulting downtime is expensive, both regarding repair costs and lost productivity.

To protect the pump system from dry-running, it is extremely important to analyse how much water the well can supply. From here, you will be able to estimate the availability in relationship to peak demand.

Before you can perform a reliable well test however, you must:

- Install a pump with the correct capacity
- Read the drawdown of the water level at different flows
- Measure the flow at different throttling positions of the discharge-regulating valve



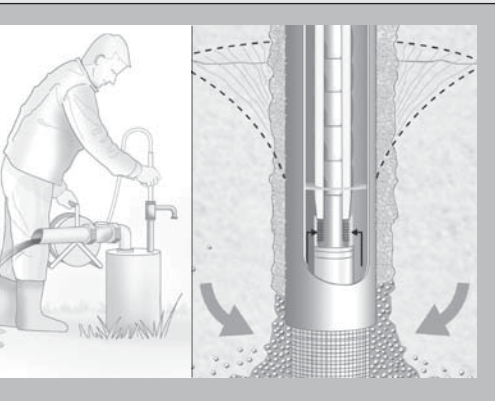

*Checking well capacity is very important*



### Test procedure

1. Start your pump with the valve closed. Register the depth to static water level.
2. Open your regulating valve to approximately  $\frac{1}{4}$  of your peak-load demand.
3. Measure the depth from the surface to the dynamic water level.
4. Fill a 1-litre jar with water from a bottom tap of your discharge piping.
5. Seal the jar; label it  $\frac{1}{4}$ .
6. Perform the testing at  $\frac{1}{4}$  peak demand for another 15 minutes. Re-check the depth to the dynamic water level.
7. If it has fallen, note by how much.
8. Repeat this procedure for  $\frac{1}{2}$ ,  $\frac{3}{4}$ , and 1/1 (peak load demand).

After approximately one hour, you will have four different relations between flow and depth to the pumped water level. You will also have four water samples:  $\frac{1}{4}$ ,  $\frac{1}{2}$ ,  $\frac{3}{4}$ , 1/1.

9. Open the regulating valve completely. Register the capacity from the pump and the depth to pumped water level.
10. Fill up jar number 5, seal it, and note down the actual capacity on the jar.
11. Leave your installation running. Activate all possible pumping installations within a 1.5 km radius.
12. Upon your return to the test site, note the performance and depth to water level at same performance.
14. The test is concluded. Stop the pump and store all five samples so that vibrations, heat, or sunshine will not affect them.

### Analysing the test results:

Examine the test data the following day. It is important that you do not touch the jars, but only look. You need to establish whether there is sand at the bottom of the samples.

1. Examine sample  $\frac{1}{4}$ . Is any sand present on the bottom?  
Calculate the specific capacity of the well at  $\frac{1}{4}$  of peak demand.
2. Examine sample  $\frac{1}{2}$ . Is any sand present on the bottom?  
Calculate the specific capacity of the well at  $\frac{1}{2}$  of peak demand.
3. Perform the same procedure for  $\frac{3}{4}$  of peak load demand and for full flow (1/1).  
Comparing your calculations of specific pumping capacities will support your decision to extract the capacity range with the same  $\text{m}^3/\text{h}$  per metre drawdown.

## 2.1.2 Ground water troubleshooting

Situation	Reason	Remedy
There is sand at the bottom of the glass at a specific capacity.	You are over-pumping your well.	If sustainable pumping is your target, never pump harder than approximately half capacity of the sand yielding capacity.
The specific capacity falls off, causing reduced m <sup>3</sup> /h per metre drawdown.	You have passed the limit of long-term sustainable pump flow.	Reduce the flow.
Pumped water level is lowered during pumping periods at the same flow.	Your water sources are limited.	Additional storage capacity for peak demand irrigation supply.
The pumped water level drops when neighbouring pump stations start up, while pumping at the same flow.	The pumping stations compete for a limited amount of water.	Additional storage capacity for peak demand irrigation supply.
The total efficiency is lower than 50%.	Pump wear or incorrect pump selection.	Replace pump with one made of more appropriate material.
Excessive power consumption or insufficient irrigation capacity.	The pump may be clogged with sand, silt, or rust, causing flow-restricting friction.	Flush the piping section by section at the highest possible flow creating at least 5-6 m/s velocity.  OR  Insert a sponge to create the cleaning/rinsing velocity.  Install sand cyclones or bag filters at your well head to prevent future clogging.



*Corrosion can be devastating*



### 2.1.3 Pump wear

An incorrect choice of pump material and the resulting pump wear is a common problem reducing well capacity. Choosing the correct pumps with vital components made from bronze or stainless steel from the beginning will secure a reliable, energy-efficient, and virtually maintenance-free ground water pump solution.

Rust on cast iron pumps is created by iron from the impeller, which oxidises through contact with the oxygen in the water. When the impeller rotates, the rapidly flowing water (5-15 m/sec) removes rust from the impeller surface. This corrosion/erosion process leads to the loss of impeller material. When impeller material is lost, capacity and efficiency also fall.

Review the following factors prior to choosing your impeller and subsequent pump:

**Tip: Choose your pump construction according to the criteria below. Please note that these are only general guidelines.**

Ground water temp.	pH value	Oxygen in water	Irrigation period	Impeller material
Less than 10°C	Higher than 7	No	Short	Cast iron
Higher than 10°C	Lower than 7	Yes	Long	Bronze/composite or stainless steel

#### Testing your system:

Insufficient capacity is often caused by periods of inactivity. Therefore, it is important to test the performance of your equipment at takeover of an existing pumping system and every year before start-up.

When your irrigation machinery is operating, you should calculate the efficiency of your pumping equipment. Use the following equation:

$$\text{Efficiency} = \frac{(\text{manometric reading at the well head} + \text{drawdown}) \times \text{capacity}}{367 \times \sqrt{3} \times l \times V \times \cos \varphi}$$

$$\text{Cos } \varphi = 0.85$$



## Service intervals for submersible pumps

Submersible pumps are subject to wear just like all other pumps. Unfortunately, their placement underground makes viewing this wear difficult. The diagram here enables you to calculate the following:

- When should I service my submersible pump?
- How much efficiency has been lost since the last service?
- How much will a renovation cost (approximately)?

A number of things must be determined beforehand. They include:

- Water velocity at the component you wish to test
- The conditions related to pump material and the pumping environment
- The presence or absence of solids and aggressive carbon dioxide.

1. See point 1 on Curve A. Pump material and media conditions are as indicated in the legend.
2. Draw a parallel line to the right. Impeller material loss is around 0.18mm per 1,000 hours of operation (point 2).
3. Follow the parallel line until you reach the differentiation line that corresponds to aggressive CO<sub>2</sub> and component material. Note the conditions in our example (point 3).
4. Drop directly down (90°). The aggressive CO<sub>2</sub> content has raised material loss to 0.25 mm. Note the salinity level of the water (point 4). Draw a horizontal line through this point, and follow it to the left and read the results.
5. Recommended service intervals for your pump: After every 6,000 hours of operation (point 5).
6. Loss of efficiency: Approximately 18% (point 6).
7. Approximate cost of renovating the pump: 75% of new pump price (point 7).

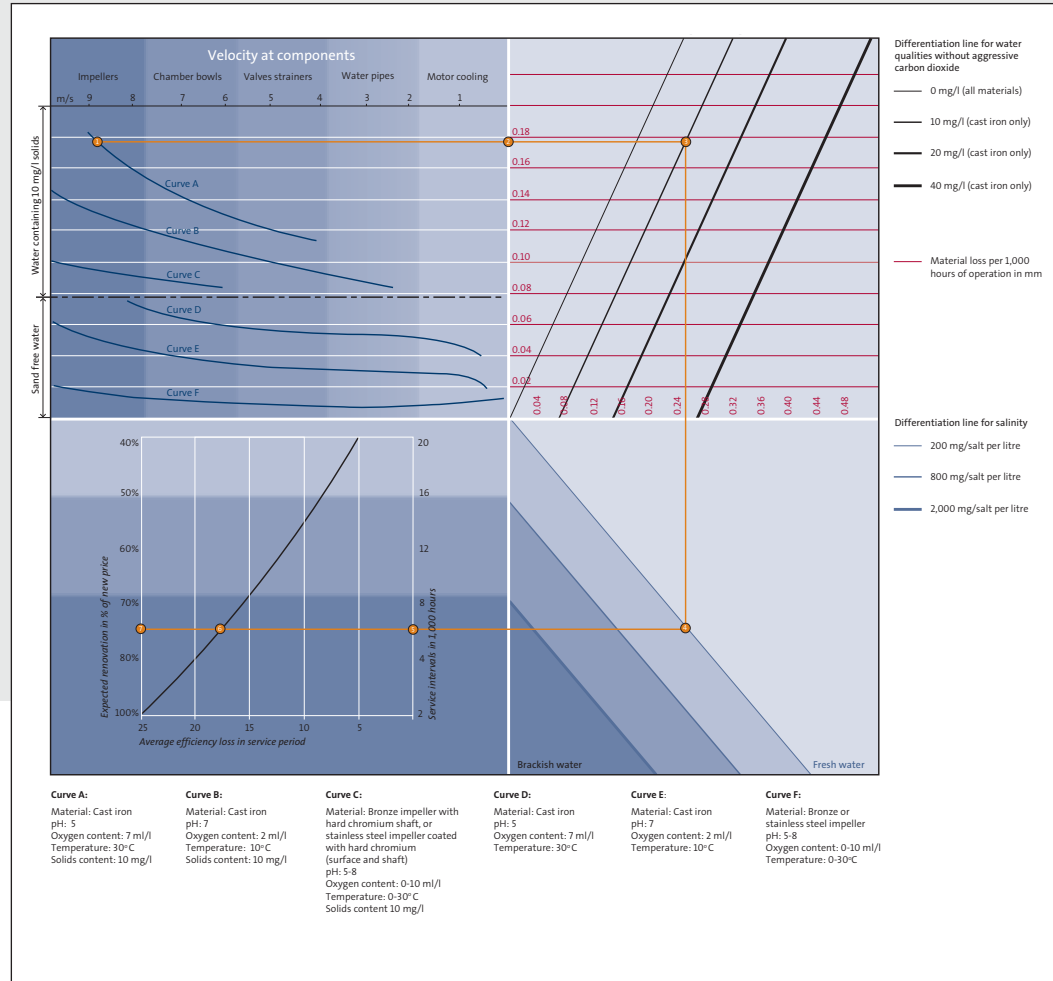



*Particles in the raw water can cause pump wear*

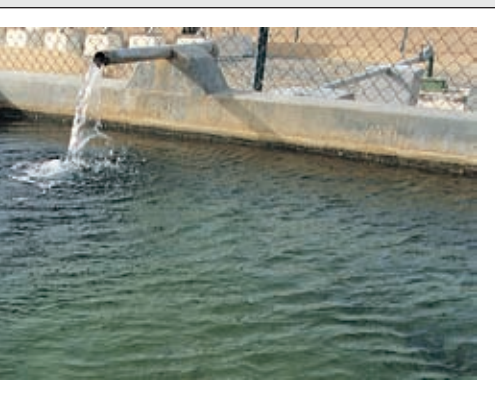

#### 2.1.4 Clogging

Piping that is partially filled with sand, silt, or rust may cause some of the following problems:

- Excessive power consumption
- Insufficient water capacity
- Pump wear

Employing one or more of the following can prevent clogging;

- Sand cyclone or bag filter: These filters prevent sand, silt, and rust from entering the piping system.
- Open resource/pond: Can be used when particle size is too small to be retained by cyclones and bag filters. Silt falls to the bottom, and irrigation water is removed from the top.

**Please note:** When introducing the open settling resource/pond, the ground water pump must usually perform only half lift. The distribution pumps from the reservoir/pond produce the nozzle pressure, overcoming friction loss in the piping.

As the head demand might relate to the velocity at the impeller and bowl, a settling basin solution reduces the required head from the ground water pump. Furthermore, this solution often extends the service intervals of the ground water pump.

### 2.1.5 Overpumping

Sometimes peak demand capacity causes overpumping of the well to the level of sand intrusion. Damage can be avoided by installing one or more of the following:

- Sand separator or Telescope-inserted filter section: This will reduce the quantity of silt and sand in the water. Retarding the entrance of these characteristics into the pump will also eliminate the resulting wear and tear.
- A 3-second ramp for soft start/stop:  
Starting a ground water pump when aquifer volume is full will result in excessive performance during the first seconds of operation. This high-capacity kick starting lifts up/releases sand and silt in the aquifer, drawing it into the pump.

This powerful suction is eliminated by a 3-second ramp soft start/stop.

#### Special notes:

- If a VFD is introduced, remember to adjust the start frequency to 25 Hz and ramp it up from here. Submersible motors are equipped with water-lubricated slide bearing systems, which are not lubricated below 25 Hz.
- Select pumping equipment with a Sic/Sic mechanical shaft seal on the motor to protect against sand/silt intrusion to the motor bearing. Installing a cooling sleeve with a cooling flow velocity higher than 1 m/s will prevent silting up around the motor.

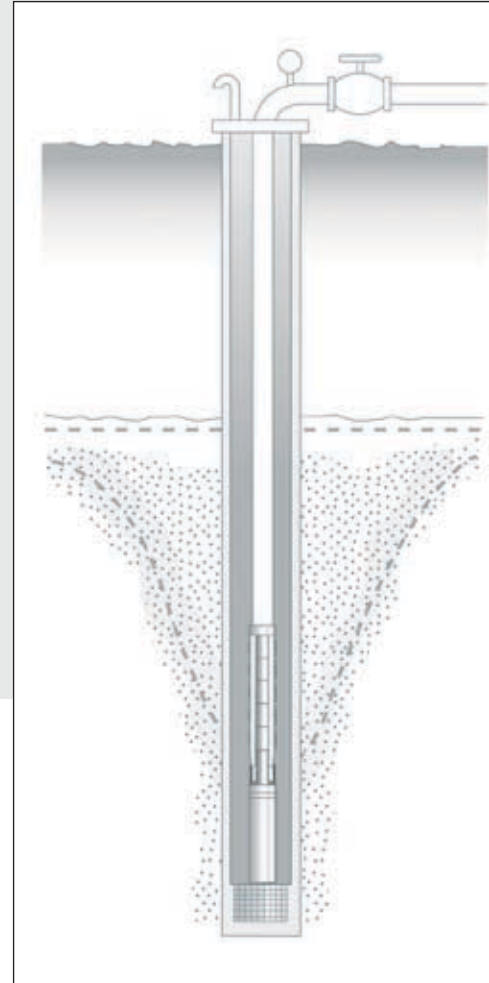



*There are many types of surface water available*



## 2.2 Surface water

Surface water includes springs, lakes, and rivers. If the capacity of the surface water source meets the peak demand, this source is usually just as good as ground water for irrigation purposes.

Surface water flow is relatively easy to understand because it is readily observed and easily measured. However, there are certain characteristics of surface water supply that you have to consider before selecting the pump system.

Connecting your irrigation intake to natural flowing water calls for extra attention regarding:

- Intake structure design
- Overcoming dry seasons and droughts
- Lowering of water level by other users (public water supply)
- Destruction of equipment from flooding
- Theft risk (drawing from public areas)

### 2.2.1 Intake structure design

When designing your intake structure, it is important to understand that the surface water in the rainy/snow-melting season carries large quantities of mud, silt, and suspended materials. Constructing a settling canal ahead of pump suction can prevent this matter from entering your system and causing detrimental wear.

### 2.2.1.1 Settling canal

To allow for particle settling, the canal must be at least six metres long and have a water level height that brings down the canal flow velocity to max. 0.015 m/s, when pumping at design flow.

If the length of the calming section of the canal is less than six metres, wind and wave activity as well as pump size may negate the settling function.

$$W \times H = 0.015 \times Q/2826$$

**Q = design flow in m<sup>3</sup>/h**

**W = width in metres**

**H = height in metres**

#### Additional notes:

- The width of the canal must allow for mechanical sediment removal. Before starting your irrigation season, the settling canal must be desilted to ensure proper operation.
- During the summer, heavy marine-life growth such as mussels, larvae, aquatic plants, etc. can cause problems. Cover the settling canal to prevent sunshine and daylight from fuelling this organic growth.

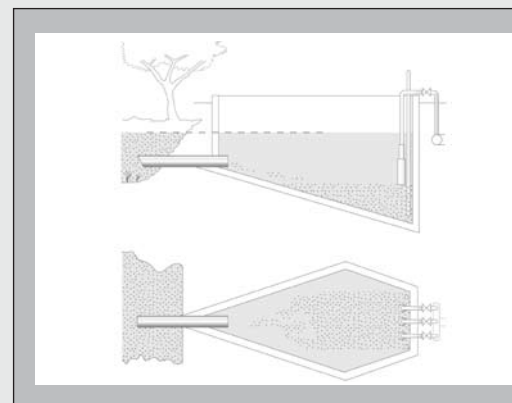

*Water from a settling canal can be used directly*

*Settling ponds have a two-section construction*

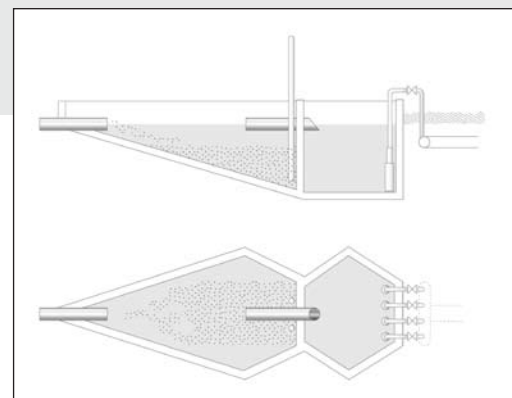

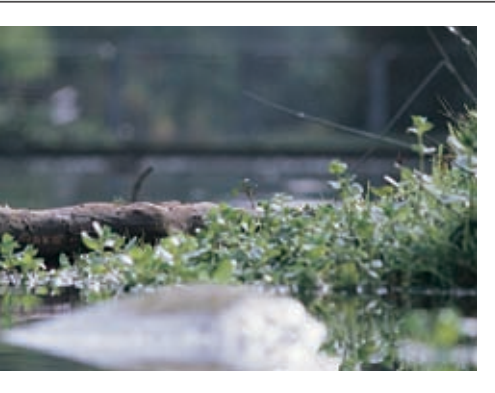

*Riverbank injection uses natural percolation and wells*

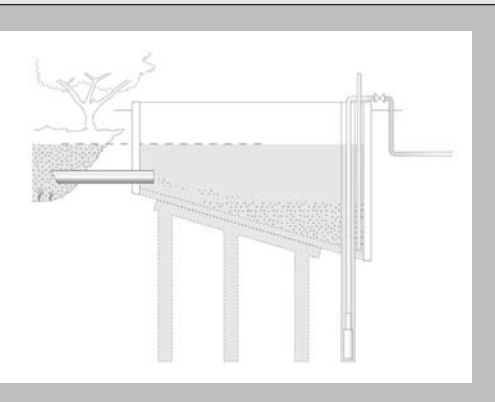

## **2.2.2 Overcoming dry seasons and droughts**

If there is a chance that your surface water source could dry out during the hot season, your intake canal should be equipped with an ordinary injection well. This design is called riverbank injection.

### **2.2.2.1 Riverbank injection**

In rainy seasons, when river levels stand high, the river intake structure injects huge quantities of river water into your aquifers. During dry seasons, when river levels run low, the submersible pump in the injection well recovers the injected river water from under the ground.

### **2.2.2.2 Lowering of water level by others (public water supply)**

If you share your water source with any other water extractor (such as a municipal system) during the dry season, you should be aware of this. Solving this problem can be accomplished in two ways:

- Create storage facilities such as a tank, pit, or cavern
- Dig your present storage facility deeper

### 2.2.3 Destruction of equipment from flooding

If the risk of flooding exists, submersible pumps should be installed instead of dry motor pumps. Well superstructures such as shown in the illustration are not water-tight. The pump and motor inside will be destroyed should the flooding reach the level found several years ago.

### 2.2.4 Theft risk (drawing from public areas)

If your freestanding equipment is at risk of being stolen, Grundfos recommends a special construction. Here, locked-down submersible pumps can be a part of the construction. Very special equipment is required to be able to remove the pump and accompanying accessories.

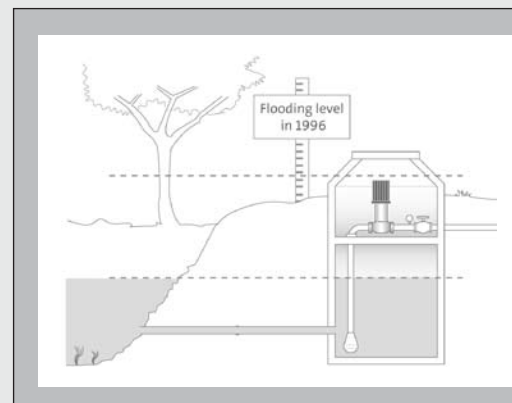

*Well superstructures must be placed above the flooding risk level*

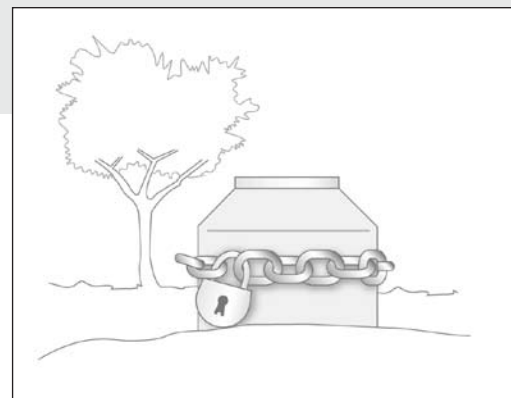

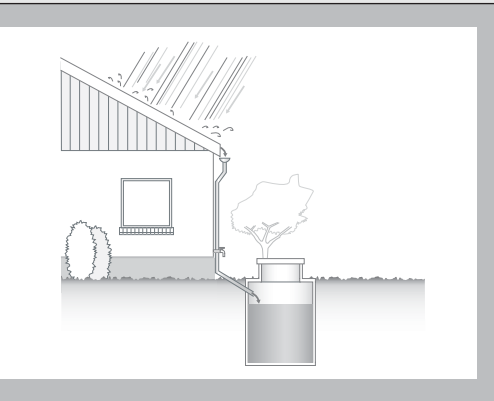

*Rain water can be harvested and stored for later use*



## 2.3 Rain water & NEWater

When neither ground nor surface water is available or able to supply peak irrigation demands, other sources can be utilised. These include:

- Rain water harvesting
- Upgrading low source quality (NEWater/recycling)
- Import of irrigation water by tank vehicle

### 2.3.1 Rain water harvesting

The harvesting of rain water simply involves the collection of water from surfaces on which rain falls, and subsequently storing this water for irrigation. Normally, water is collected from the roofs of buildings and stored in rain water tanks. However, water can also be collected in dams from rain falling on the ground and producing run-off. Rain collecting surfaces, also called catchment areas, are:

- Roofs
- Roads
- Paved areas

#### 2.3.1.1 Source capacity

To secure a sufficient rain water supply for irrigation, the size of the catchment area must be calculated. The following factors must be considered:

- Peak demand
- Monthly average rainfall for the area
- The size of the cisterns or tanks where the collected rain water is stored

Based on the water supply budget, you will then need to match the size of the catchment area and storage tanks with the irrigation demand.



### 2.3.2 NEWater or water recycling

NEWater is treated used water that has undergone some purification and treatment process using microfiltration and reverse osmosis. The quality of membrane technology has improved greatly over the years. It is now possible to even turn seawater into potable water at a power consumption cost of less than 3 kWh/m<sup>3</sup>. This low power consumption makes reverse osmosis an acceptable process for irrigation of high-value crops.

Reverse osmosis membranes have a present lifespan of approximately five years. This is constantly improving as durability increases. For the latest on R.O. technologies, we recommend contacting:

Affordable Desalination Coalition  
Point Hueneme, CA, USA  
Tel: +1-650-283-7976  
E-mail: [jmacharg@affordabledesalination.com](mailto:jmacharg@affordabledesalination.com)

### 2.3.3 Upgrading low source quality comparison

The major cost factor when providing water for irrigation is the power consumption necessary to treat and deliver the right water volume at right pressure. For low value crops, irrigation is only feasible if high source-quality surface water or ground water is available in right quantities.

In recent years, the energy efficiency of membrane technology has improved to bring the energy consumption below 3 kWh pr. m<sup>3</sup> of irrigation water. This makes it beneficial to upgrade (recycle) low source-quality wastewater of nearly all kinds, and for high value crops, even desalination of brackish water and seawater can now be employed.

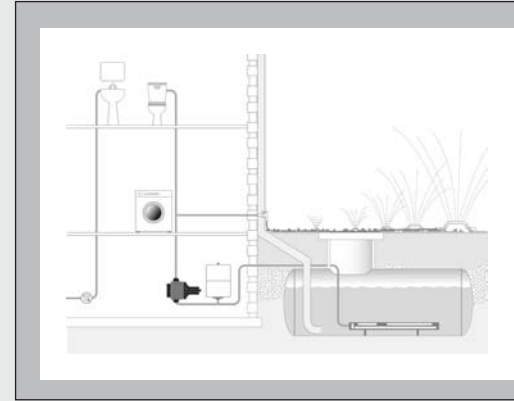

*Purifying water can be a viable option*

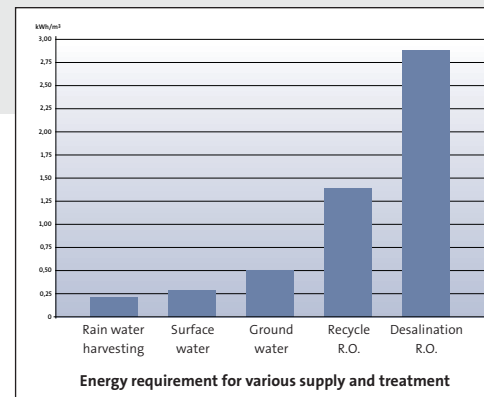



## 2.4 Storage of water

If the water source cannot adequately meet the peak demand for water, a storage reservoir can be created. Water from here can be pumped during periods of peak demand.

Installing a reservoir to equalise the difference between water source yield and peak demand necessitates a calculation of the size of the reservoir. Use the formula below to find the necessary storage volume:

$$\text{Volume} = \frac{\text{Peak demand } Q \times \text{peak hours}}{\text{production capacity} \times \text{production hours}}$$

### 2.4.1 Open-air basin

The storage can be arranged as an open-air basin constructed with modern type of foils as sealants/membranes. This will reduce leakage rates from the basin to the ground.

Advantages:

- Inexpensive to build
- Inexpensive to remove

Disadvantages:

- Evaporation loss in hot climates
- Growth of algae and moss
- Salt concentration build-up due to evaporation
- Destruction of membranes by livestock or sabotage
- Takes up non-productive space in arable land
- Risk of drowning (humans and livestock)

### 2.4.2 Water tank or underground cavern

Grundfos recommends alternative storage methods if the disadvantages listed above are deemed unfeasible. Constructing them will require various levels of investments.

Water tank: Can be constructed from corrugated steel or prefab concrete elements.

Underground cavern: Constructing a tank and covering it with arable soil.

Advantages:

- Low evaporation losses
- Low algae & moss growth
- Low salt concentrations from low rates of evaporation
- Protected from contamination by animal and plant life
- Can be covered with a roof and used for another purpose
- No risk of drowning

Disadvantages:

- Expensive to build
- Expensive to remove

### 2.4.3 Parallel operating boosters

When designing the distribution pump system from a storage basin, it is usually beneficial to choose parallel operating boosters, as this solution requires smaller motor sizes. Other benefits include:

- Reduction of starting amps
- Reduction of water hammer at start/stop
- Introduction of cost-free flow adaptation depending on crop type and irrigation demand



*Multiple pumps can draw from an underground cavern*



### 3. Crops and water

All field crops require nutrients, water, air, and sunshine to grow. The correct balance between them all contributes to the success of the harvest. Grundfos can help with the provision of water where and when necessary.

Relying on natural precipitation is perhaps the simplest form of providing water to crops. However, when more water is needed than is supplied, irrigation is the perfect solution to bridging the gap.

An important factor to note is that the amount of irrigation water needed depends on three main elements:

- the amount of water naturally present (effective rainfall)
- the amount of water needed by the crop
- the climatic conditions

These points are covered in this chapter. Combining them properly is one of the keys to efficient and effective irrigation system operation.

### 3.1 Annual amount of rainfall

The amount of irrigation required depends on the yearly rainfall and its distribution. Several divisions of climate related to the amount of annual rainfall exist.

- Humid: over 1200 mm of rain annually. This amount covers the water needs for many crops. Irrigation is usually not necessary, but may increase yield significantly in some years.
- Sub-humid and semi-arid: between 400 and 1200 mm of rain annually. This amount is not enough for many crops. Irrigation increases annual crop yield, making production possible in the dry season.
- Semi-arid, arid and deserts: less than 400 mm of rain annually. Irrigation is indispensable.

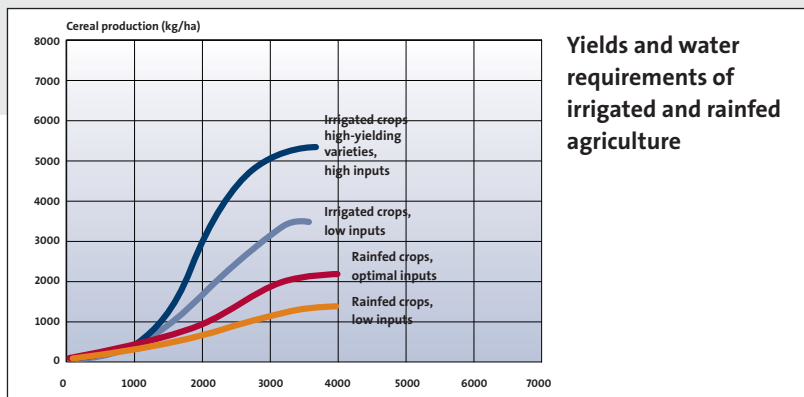

*Irrigation can increase crop yield significantly, but consumes much more water.  
(Modified on Crops and Drops: Making the best use of water for agriculture, FAO, 2002)*





### 3.1.1. The need for irrigation

Irrigation is needed when a precipitation deficit occurs. Even in areas where the average annual rainfall is sufficient to cover average evapotranspiration, some periods will require irrigation.

For example, this situation occurs every year in arid and semi-arid regions, such as in the Mediterranean part of Europe. In humid and semi-humid regions, such as in Northern Europe, precipitation deficits occur in some years and only temporarily in the crop-growing season.

*Annual precipitation is crucial*

**Precipitation deficit in temperate ares**

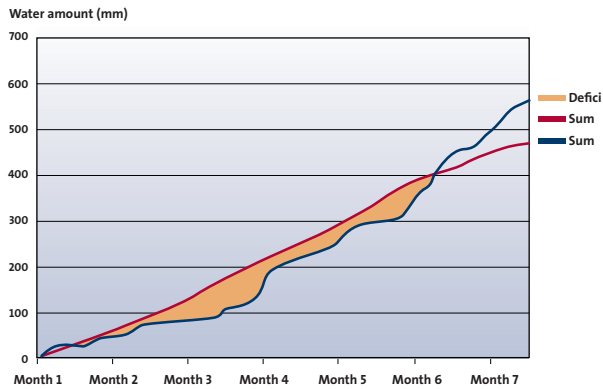

**Precipitation deficit in sub tropical ares**

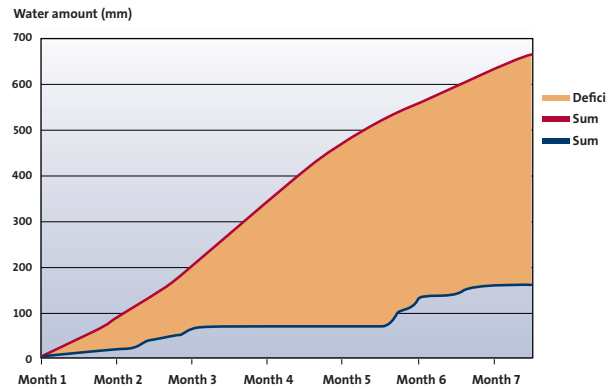

### 3.1.2. Gathering data

Crop and irrigation water needs are known in some countries, and distributed by the Irrigation Department, Ministry of Agriculture, or other local authorities. If this is not possible, the data needs to be calculated on the spot.

The basic equation for calculating irrigation water needs is shown below:



### Calculating irrigation water needs

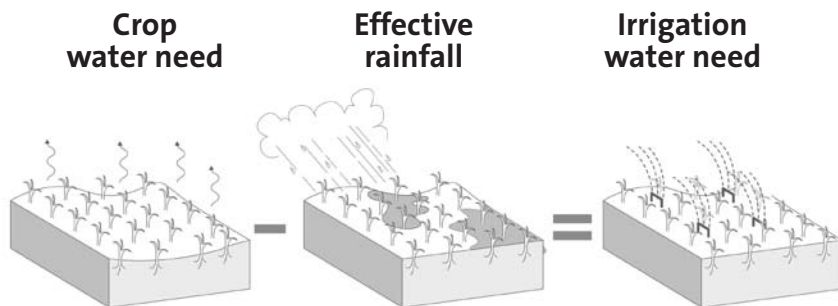

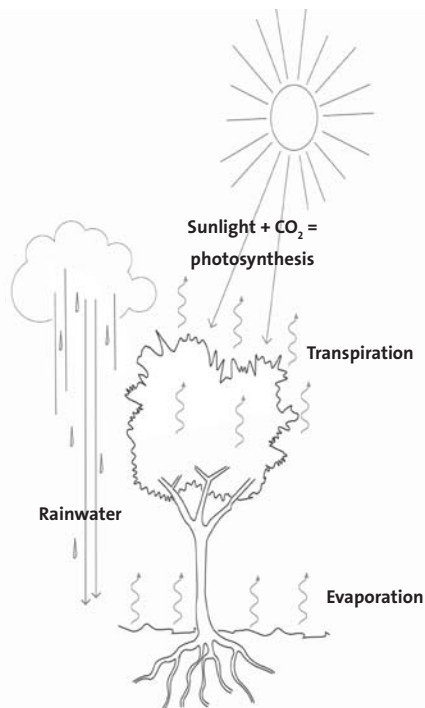

### 3.2 Crop water needs

The plant's roots draw water from the soil for growth and survival. However, most of this water escapes as vapour through the plant's leaves through transpiration.

From an open water surface, which may be found on the soil as well as on plant leaves, water escapes directly through evaporation.

The water need of a crop is therefore known as “evapotranspiration”, where transpiration and evaporation are added. This water need is most commonly expressed in mm/day, mm/month, or mm/season.

For crops, the water uptake and loss by evapotranspiration is essential for achieving high yields of good quality. This water flow enables the crop to:

- Utilise the sunlight to produce structural matter through photosynthesis
- Draw important nutrients from the soil
- Control the temperature of its surfaces

*During photosynthesis, plants convert water, carbon dioxide, and sunlight into structural matter and oxygen*



### Example of crop water need

You have a crop in a sunny warm environment with a water need of 10 mm/day. Note that these 10 mm do not need to be supplied every day. 50 mm of irrigation water can be applied every 5 days. The root zone will store the water until the plant needs it.

The three major factors that determine crop water needs are:

- The climate: crops grown in a hot climate need more water per day than in a cloudy and cold climate
- The crop type: rice or sugarcane require more water than carrots or olives
- The growth stage: fully developed crops need more water than newly planted crops

#### 3.2.1 The climate

Maize grown in a sunny, hot climate obviously requires more water per day than maize grown in a cloudy, cold climate. The humidity and wind speed also play into this equation, however.

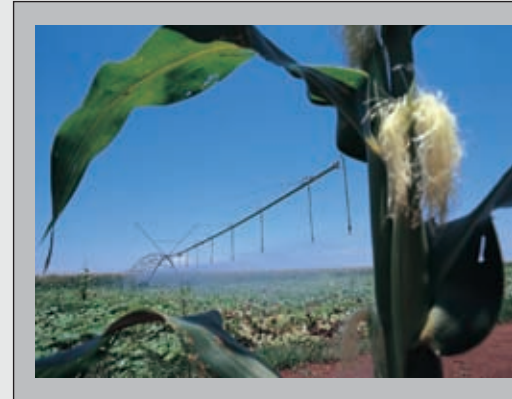



*Crop type is very important when calculating irrigation needs*



### 3.2.2 The crop type

Two factors affecting the crop water need are related to the crop type. One deals with the size of the crop when fully developed; the other deals with the length of the growing season.

- Physical size: Maize plants will draw much more water than wheat
- Length of growing season: short duration crops such as peas grow for 90-100 days; longer duration crops such as melons grow for 120-160 days

While, for example, the daily water need of melons may be less than the daily water need of peas, the seasonal water need of melons will be higher than that of peas because the duration of the total growing season of melons is much longer.

After mid-season, some crops do not need the peak amount of water any longer. Fresh-harvested crops such as lettuce, tomatoes, and melons, on the other hand, require the peak amount until harvesting.

The influence of the crop type on both the daily and seasonal crop water needs are discussed in the sections on page 36.

### 3.2.3 Growth stage

Evapotranspiration is plant transpiration combined with evaporation from the soil and plant surface. Smaller crops require less water than mature crops. On the other hand, the evaporation from the soil is greater when the crops are smaller with more soil exposed to sun and wind.

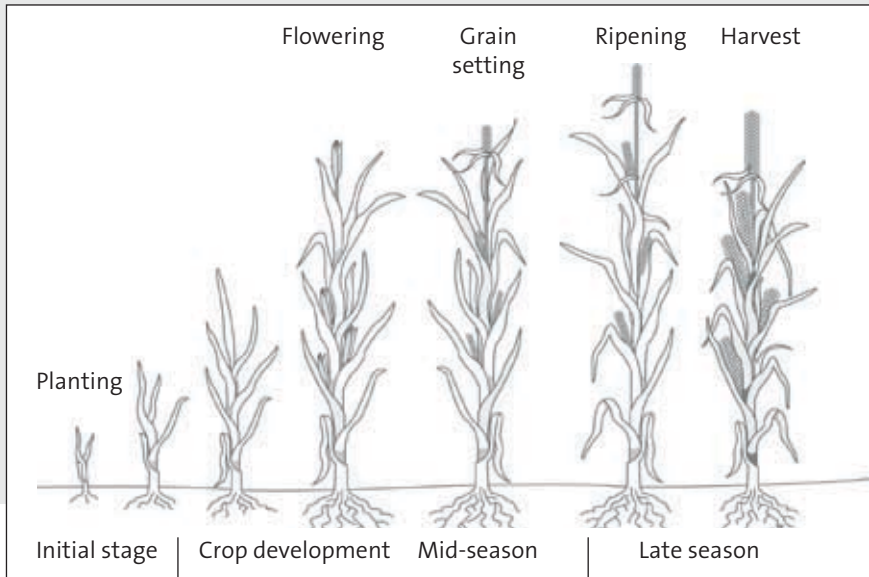

Note that the crops themselves will typically only need approximately 50% of the water they need during mid-season when they blossom and set grain. This peak need is found at the beginning of the mid-season stage. This is the high point for water need. Remember that irrigation systems should be dimensioned to meet these demanding periods.





*The climate can dramatically change the crop water need for the same crop*



Again, the climate plays an important role in crops water need. Note the differences between the same crops when grown in different climates.

Crop	Water needs			
	Sub tropical climate		Temperate climate	
	Yearly	Daily (peak)	Yearly	Daily (peak)
	m <sup>3</sup> /ha/year	m <sup>3</sup> /ha/day	m <sup>3</sup> /ha/year	m <sup>3</sup> /ha/day
Cereals	2,000-3,000	110	1,000 - 1,500	65
Leguminous plants	5,000	110	2,500	65
Tubers (potatoes)	6,000	110	3,000	65
Soya	4,000	110		65
Beet root	7,500 - 8,000	95	3,700 - 4,000	57
Alfalfa	8,000 - 9,000	115	4,000 - 4,500	70
Fodder maize	4,000 - 5,000	115	2,000 - 2,500	70
Maize and sorghum	8,000	110	4,000	65
Fruit trees	5,500	90	2,800	55
Wine	1,500 - 2,000	65		
Turf grass	10,000	100	6,000	60

### 3.2.4 Effective rainfall

Contrary to what you may think, not all rain water that falls can be used by the plants. Some percolates deep beneath the surface; some flows away as run-off. The root zone stores the remaining rain water. These millimetres are known as the effective rainfall.

The climate, soil texture and structure, and the depth of the root zone all affect the amount of effective rainfall. Where rainfall is heavy, a large percentage of it is lost through percolation and run-off. The saturated soil simply cannot absorb more water.

Another factor that needs to be taken into account when estimating the effective rainfall is the variation of the rainfall over the years. Especially in low rainfall climates, the little rain that falls is often unreliable; one year may be relatively dry and another year may be relatively wet.

The effective precipitation is estimated on a monthly basis, using measured rainfall data and local information, if available.

If effective precipitation becomes insufficient, the minerals and salts in your irrigation water will increase in the soil. The salinity will increase, and your crops will be negatively affected.

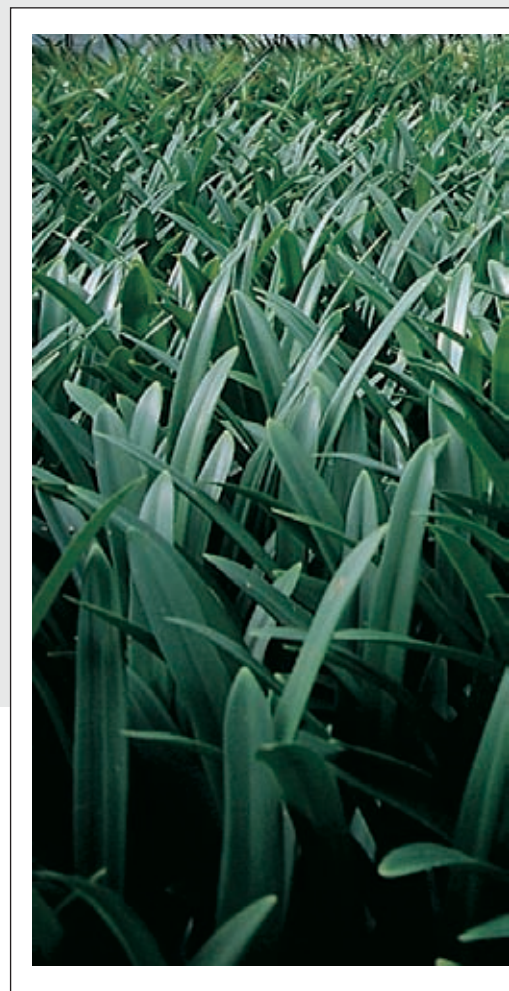

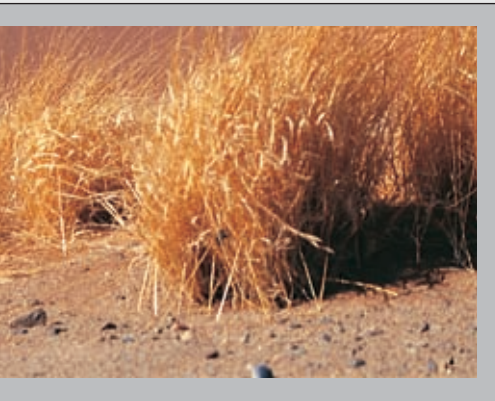

*Crop roots hold onto the soil and keep dust down*



## 3.3 Other applications

### 3.3.1 Dust control

To improve the air quality of the major cities, governments especially in Asia are establishing green belts of trees and shrubs to create anti-storm forest barriers around the cities. These windbreaks reduce dust and redirect wind, and thereby improve the environmental conditions or microclimate in the sheltered zone. At the same time, keeping sand and dust at bay also calls for preventing desertification by recovering vegetation near desert areas.

To ensure that the vegetation grows and in that way provides sufficient defense against the sand and dust threats to the cities, adequate irrigation systems are required – especially during dry periods.

### 3.3.2 Fire prevention

A fire control irrigation system does not itself extinguish fires. Rather, it ensures that green areas surrounding hospitals, schools, etc. are kept moist and thereby serve as fire buffer zones or defensible spaces against wildfires.

Dead weed, trees and dry grass represent hazardous fuels that neither slow down nor stop fires from spreading. However, especially green grass and olive groves have proven very fire resistant, provided they are irrigated properly, are widely spaced, and have high moisture content.

### 3.3.3 Frost protection

Sprinkling is used a lot for frost protection of crops. By adding water to the surface of the crops, and by making sure there is always some water on the crop surface, whether any ice or not, the temperature can never get below zero, and the crops are perfectly protected from freezing.

A rule of thumb suggests a 1 mm water application rate per hour for every one degree celcius below zero to provide protection.

If the 1 mm of water is converted to  $l/m^2$  it looks like:

$$Q_{fp} = 1 l/m^2/h/deg.C.$$

where  $Q_{fp}$  is the minimum flow rate to protect the crops against freezing.



## 4. Irrigation water quality

Water for irrigation usually comes from the following sources:

- Rain water
- Surface water
- Ground water

In each case, the water has absorbed a range of metals, minerals, salts, pathogens, and biocides along the way. Removing them before applying the water is therefore very important. Several methods can be employed to do so.



## 4.1 Bag filtering

This mechanical and biological filtering system removes dissolved minerals, salts, pathogens, and biocides present in the water.

The permeability of the bag you choose needs to be directly related to the matter you need to remove. The micron rating given to each bag is based upon the size of the square mesh openings formed in the weaving process. The smaller the rating, the smaller the particles need to be in order to pass through the filter. This therefore provides finer filtering.

Primary bag filtration removes coarse dirt, sedimentation, oils, etc. Very small micron-rated bag filters can remove dissolved matter, in a process similar to reverse osmosis.

If the water is acidic, alkaline, gassy, or aggressive, it must be treated through traditional filtering and chemically stabilised. Open tank systems with efficient aeration are recommended for this process.

## 4.2 Carbonising

In some very humus soils, carbonising of the drip waters improves plant growth by 10 - 20%.  $\text{CO}_2$  and/or  $\text{CO}_3$  is added primarily from compressed gas cylinders.

## 4.3 Direct fertilisation

Some of the nutrients required for plant growth can be mixed directly into the irrigation water. This fertilisation through irrigation reduces labour costs and makes the washing off of fertiliser during heavy rains a minor issue.

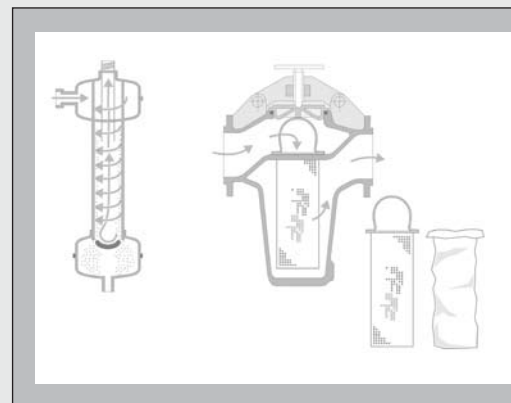

*Bag filtering consists of mechanical and biological water quality improvement*

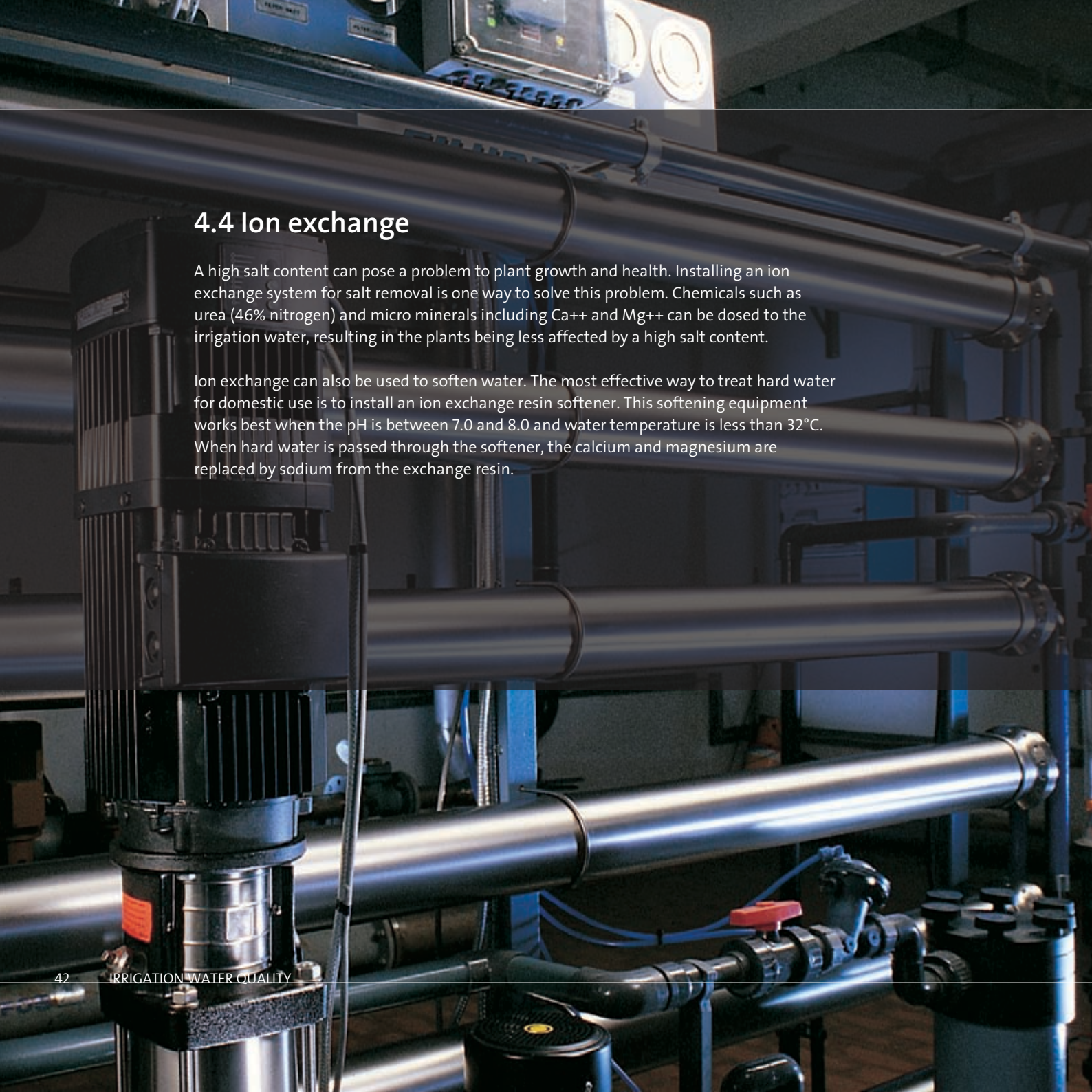

A photograph of a water treatment facility. The image shows a complex network of stainless steel pipes and machinery. In the foreground, there is a large vertical cylindrical tank with a motor on top. To the right, there are several horizontal pipes of varying diameters. In the background, a control panel with a digital display and several buttons is visible. The lighting is somewhat dim, with some highlights on the metallic surfaces.

## 4.4 Ion exchange

A high salt content can pose a problem to plant growth and health. Installing an ion exchange system for salt removal is one way to solve this problem. Chemicals such as urea (46% nitrogen) and micro minerals including  $\text{Ca}^{++}$  and  $\text{Mg}^{++}$  can be dosed to the irrigation water, resulting in the plants being less affected by a high salt content.

Ion exchange can also be used to soften water. The most effective way to treat hard water for domestic use is to install an ion exchange resin softener. This softening equipment works best when the pH is between 7.0 and 8.0 and water temperature is less than  $32^{\circ}\text{C}$ . When hard water is passed through the softener, the calcium and magnesium are replaced by sodium from the exchange resin.

## 4.5 pH adjustment

The pH-value of your irrigation water directly affects the availability of most elements, especially micronutrients.

- Too low a pH can result in increased micronutrient availability that can lead to phytotoxic responses in some plant species
- Too high a pH will lock out some elements that become unavailable to the plants

### Problems associated with “out of range” pH:

Low pH causes:

- Toxicity in iron (Fe), manganese (Mn), zinc (Zn), copper (Cu)
- Deficiency in calcium (Ca), magnesium (Mg)

High pH causes:

- Deficiency in iron (Fe), manganese (Mn), zinc (Zn), copper (Cu), boron (B)

For example, if the pH is too high, iron may become unavailable. Even though your nutrient solution may have an ideal iron content, your plants may not be able to absorb it, resulting in iron deficiency. The plant’s leaves will yellow and weaken.

### Different crops prefer specific hardness ranges (see examples)

Crop	Preferred pH
Potatoes	5.25 - 6.0
Watermelon	6.0 - 6.75
Alfalfa	6.75 - 7.5

If your water source does not correspond to the preferred pH value, it can be adjusted by adding a pH-adjustment agent directly into your irrigation flow.

The following media can be employed:

To **raise pH**: Lime milk, caustic soda

To **lower pH**: Nitric acid



*Grundfos metering/dosing pumps are perfect for the precise addition of exactly the media you need*





## 5. Drainage

For crops, water uptake, and evapotranspiration is essential for achieving high yields of the best possible quality. What's more, the plants utilise evapotranspiration, sunlight, and CO<sub>2</sub> uptake to produce structural matter from the nutrients in the soil or irrigation water. Additionally, the surface of the plants is kept at the optimal temperature for growth.

Evapotranspiration, photosynthesis, and temperature regulation are hampered if metals, salts, or minerals accumulate in the soil texture around the rotting zone. For most agricultural crops, the maximum permissible content of salt is approx. 0.1%.

### Addition of salt content

Irrigation with 100 mm of water with a salt content of 0.1% means a salt increase of 1,000 kg/ha. Unless this additional salt content is leached through natural precipitation during non-irrigation periods, soil productivity will be drastically reduced.

If this natural leaching does not take place during non-irrigation periods, the maximum advisable salt content is 0.05%, dependent on:

- The soil type
- The crop to be grown
- The irrigation method

Some crops such as cotton, can tolerate a salt content of up to 0.3%, 3000 T.D.S.

### Saturation

Nutrient content can fall greatly if the soil texture remains saturated for long periods of time. Covering the soil is one way to avoid saturation, yet side effects such as rotting and soil texture digestive processes occur. These side effects arise when the soil is deprived of air.

Efficient drainage is therefore essential to ensure the maximum effects of irrigation.

### Drainage level depending on type of soil

Type of soil	Solution	Depth	Location
Sandy	Ditches	Approx. 120 cm	Surrounding irrigated fields
Silty/clayish	Below-ground piping	Approx. 120-150 cm	Below ground, in irrigated fields

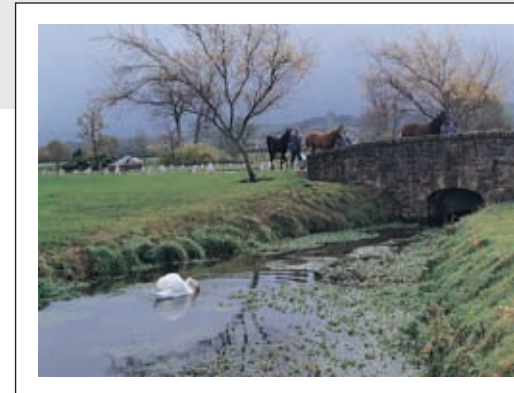

## 6. Pump catalogue

This chapter contains some basic information on the most commonly used Grundfos pumps for irrigation. Please note that these pumps represent only a small fraction of Grundfos' extensive product portfolio.

We nonetheless recommend that you always consult the Grundfos WinCAPS or WebCAPS for pump sizing, or your local Grundfos representative for detailed product and application information before making your final selection.

Pump selection is thankfully not as complicated as rocket science. However, there are certain factors to be aware of before the right pump can be chosen. Some of the parameters listed on the following pages should be considered before selecting your pump.

## 6.1 Factors to consider

### 1) Proper irrigation design layout

The irrigation system must:

- Meet the crops' need for water
- Optimise irrigation efficiency

Divide the irrigated area into zones with varied irrigation needs to solve this situation. You can choose different types of crops, or perhaps vary the exposure to sun and wind, if possible. You can select shady or sloped areas for certain crops.

### 2) Irrigation equipment

Different irrigation equipment requires different amounts of water and pressure. Therefore the equipment must be selected before selecting the pump.

The controller must not be overlooked. It controls pump performance, even turning it on and off during predefined periods. You will conserve water by not irrigating in direct sunlight, or when winds are heavy. A Grundfos controller can be programmed to optimise operation with due respect to both the crops and water conservation.

Turning the pump off for a time will allow the soil to absorb the irrigated water. Engaging it later on will improve absorption and reduce wasted water.

### 3) Source of water

The location of your irrigation water makes a difference to the pump you should select. Grundfos deep well submersible pumps are specially designed to lift water from several hundred metres underground. You can use a variety of pumps when drawing surface water.



*Choosing the right pump is crucial to the success of your irrigation system. No matter what your irrigation needs, Grundfos has it covered*

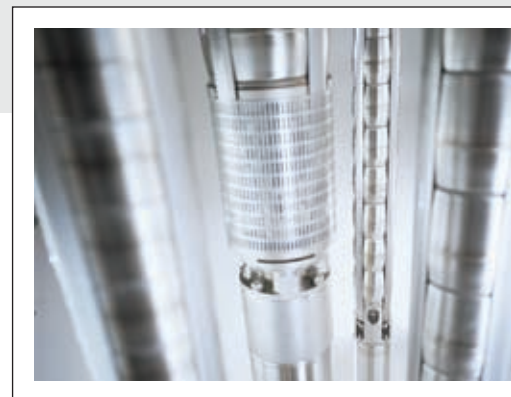

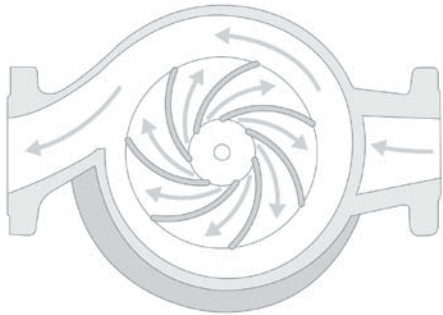
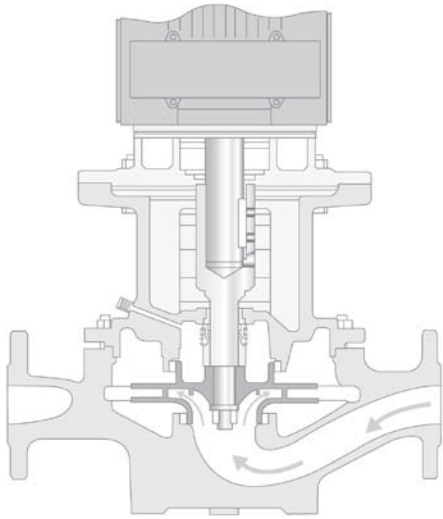

#### 4) Power consumption

Pumps and motors have different efficiencies, and the overall efficiency should always be calculated before the final selection is made. Your electricity bill will depend on how many kW the motor absorbs. Simply compare the flow and head produced by the pump with the kW consumption of the motor.

It may be calculated as follows:

$$\text{Efficiency \%} = \frac{Q \times H}{365 \times P1} \times 100$$

**Q** = flow in m<sup>3</sup>/h

**H** = head (pressure from pump in metres)

**P1** = the kW required by the motor. Note that this must not be confused with the kW output stamped on the motor nameplate.

Most pump manufacturers are able to provide all relevant data, so a true calculation of the efficiency can be made.

#### 5) Flow

Two basic elements are crucial:

- The availability of water
- The crop's need for water

When using ground water, we often recommend using more than one well in order to minimise the drawdown. We also recommend employing several small pumps rather than one large pump. Benefits include:

- Easy to cut in / cut out pumps according to flow demand
- Minimisation of leakage caused by excessive system pressure
- Energy consumption is reduced, as lifting height is limited
- Negative influences on the aquifer are avoided



## 6) Pressure

System pressure should be kept as low as possible. Reasons include:

- Reduce leakages
- Conserve water
- Reduce energy consumption

However, a specific minimum pressure for proper functioning is usually necessary. Without this, the correct performance of the irrigation equipment can not be guaranteed.

## 7) Additional considerations

Submersible pumps offer two main advantages when drawing water from a reservoir or lake:

- Improved theft protection, when the pumps are submerged
- Noise is reduced to only the noise from the pipes and the valves

Please note that in a horizontal installation in a reservoir or lake, a flow sleeve to ensure proper cooling of the motor is required.

## 8) Variable pump performance

Speed regulation is the most efficient way to adapt pump performance to output demand. Additional pumps can start and stop accordingly.

Grundfos has a range of pumps with variable speed controls, and can deliver packaged booster pumps with simple controls.

Some irrigation equipment manufacturers also design controls, which are optimised for separate pump and irrigation equipment performance.

## 9) Pump protection

Grundfos has a wide range of protection devices, warding off the most common disturbances, like overload, over or undervoltage, phase unbalance, dry run, and insufficient cooling.



## Grundfos SP / SP A / SP-G

- 4", 6", 8", 10", 12" submersible pumps



### High pump efficiency

The Grundfos range of all submersible pumps is ideal for irrigation in horticulture and agriculture. The SP range is characterised by permanent energy-efficient operation and low installation and service costs.

#### Example:

Price per kWh: € 0.10

Pumped water: 200 m<sup>3</sup>/h with a head of 100 m

Period: 10 years

Choosing a pump with a 10% higher efficiency can save you € 60,000.

*The SP range is made exclusively of corrosion resistant stainless steel components, thus offering high resistance to abrasives and corrosive agents from wells, boreholes, reservoirs, lakes, and rivers*

### Features

- High efficiency
- Long service life as all components are stainless steel
- Motor protection and controls

## Performance curves

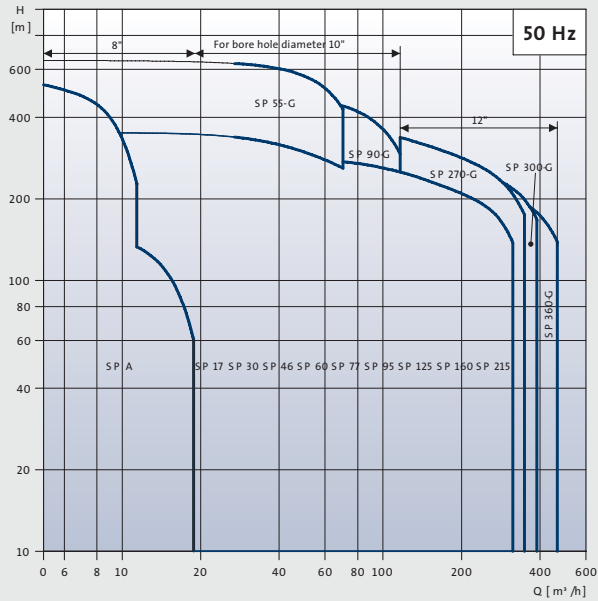

### Technical data

Flow, Q: max. 470 m³/h  
 Head, H: max. 670 m  
 Liquid temp.: 0°C to +60°C  
 Installation depth: max. 600 m

*Due to the high wear-resistance of the stainless steel, the pump is virtually maintenance-free*



## Grundfos SQ / SQ-N / SQE / SQE-N

### - 3" submersible pumps



#### **Simple installation and operation**

The Grundfos SQ pump is the standard model of the 3" submersible pump series. The SQ is ideal for smaller irrigation systems, where easy installation and operation are essential.

#### **SQE package deal**

The SQE constant-pressure package is a complete solution that doesn't require extra control units or additional connections. Everything you need for the pump installation is included in the package – control unit, pressure tank, pressure sensor, cable, pressure gauge, valve, and the submersible pump.

*Simple installation, easy operation and no maintenance have made the Grundfos SQ pump a popular choice for smaller irrigation systems*

#### **Features**

- Constant pressure
- Integrated dry-running protection
- Soft start
- Over- and undervoltage protection
- High efficiency

## Performance curves

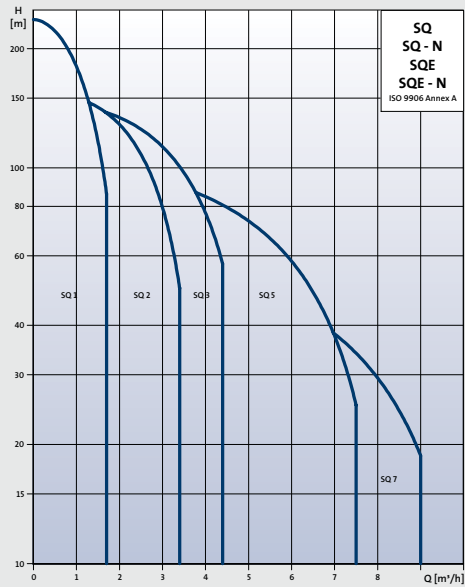

### Technical data

Flow, Q: max. 9 m<sup>3</sup>/h  
Head, H: max. 210 m  
Liquid temp.: 0°C to +40°C  
Installation depth: max. 150 m

*The SQ range of submersible pumps comes in a variety of sizes and additional options*



## Grundfos CR / CRI / CRN

### - Multistage centrifugal pumps



*CR pumps are available in a wide range of material versions according to the quality of the water*

#### **Adding constant pressure to your system**

Keeping a constant sufficient pressure in your irrigation system can be vital to secure uniform irrigation.

If your submersible pump is unable to supply a constant pressure, caused by pressure loss in the pipe work, height differences or due to long or bended piping, the Grundfos CR will secure exactly the flow and pressure that you require.

The Grundfos CR range is extremely reliable and energy-efficient. And despite the long life of the pump, it is virtually maintenance-free.

#### **Features**

- Reliability
- High efficiency
- Service-friendly
- Space-saving
- Suitable for slightly aggressive liquids

## Performance curves

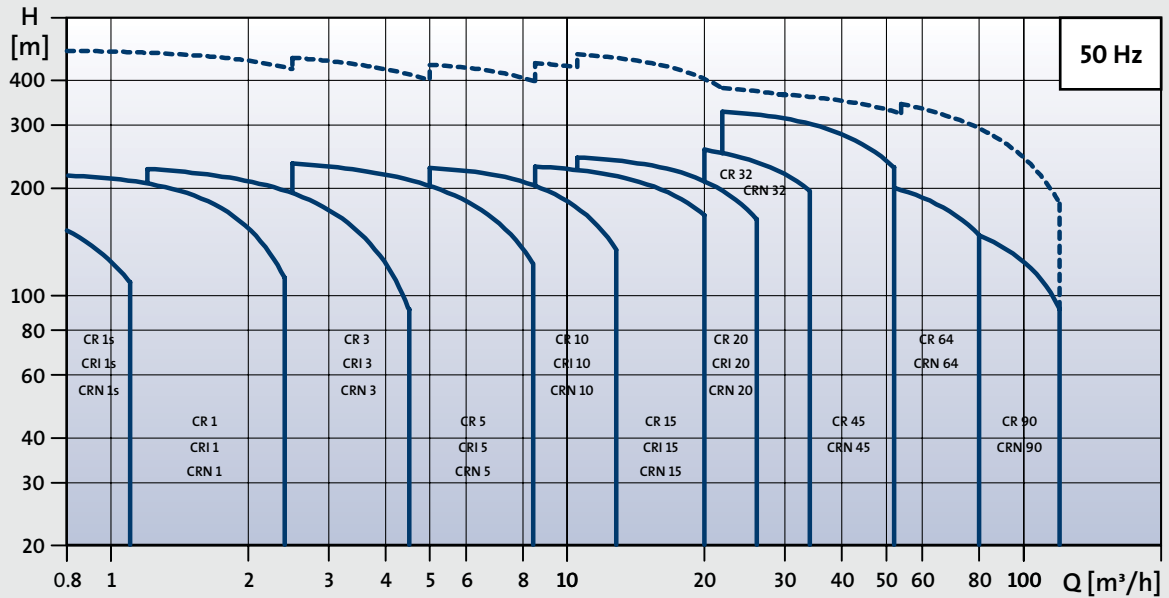

### Technical data

Flow, Q: max. 120 m<sup>3</sup>/h

Head, H: max. 480 m

Liquid temp.: -40°C to +180°C

Operat. pres.: max. 50 bar



*The CR range comes in several variants and pump sizes*

## Grundfos HS

### - Horizontal Split Case pumps

Grundfos Horizontal Split Case pumps large volumes of water and is ideal for large scale boosting or transfer of water from i.e. a river to a reservoir. Flow range from a few m<sup>3</sup>/h through more than 10.000 m<sup>3</sup>/h. Split case pumps have easy, fast and quick access for maintenance and servicing without disturbing the pipework.

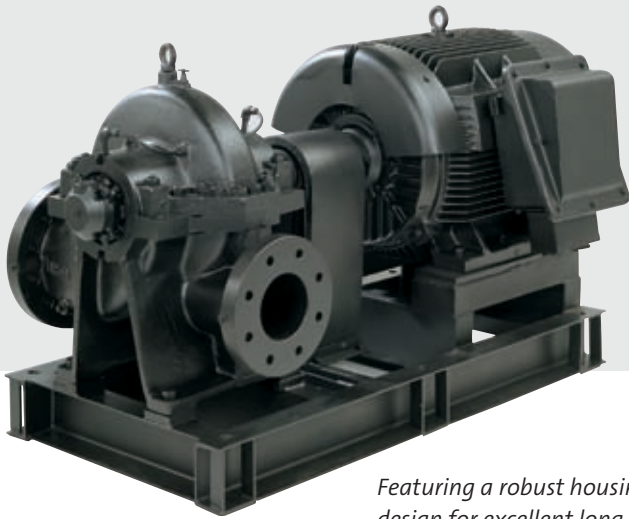

*Featuring a robust housing design for excellent long-term performance, the Split Case pumps cover a wide range of pump sizes providing reliable, economical solutions for today's irrigation applications*

#### **Features**

- Reliability
- Efficiency
- Service friendly
- Easy maintenance without disturbing pipework



## Performance curves

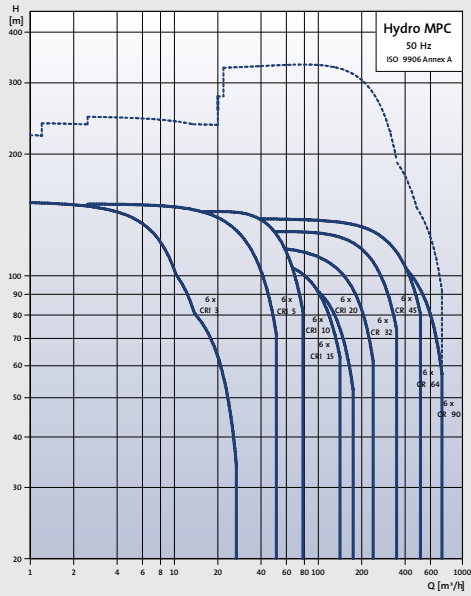

### Technical data

Flow, Q max. 4000 m<sup>3</sup>/h

Head, H max. 220 m

Liquid temp.: 0-90°C

Operat. pres.: max. 25 bar



## Grundfos Hydro 2000

### - Booster system



#### **Variable flow requirement with constant pressure.**

Maintaining the correct pressure is vital for any irrigation installation. It is important in order to irrigate the correct amount of water for the specific crops or grass. And it is important in order to conserve water. Hydro MPC can be extended with a number of sensors so it will maintain the optimal amount of irrigated water depending on weather conditions and climate. All this is done with the highest efficiency and a minimum of energy consumption.

Featuring a compact design with pumps and controls mounted on one platform ready for pumping, when suction/pressure pipes and power have been installed

#### **Features**

- Constant pressure
- Simple installation
- Low-energy
- Wide range

## Performance curves

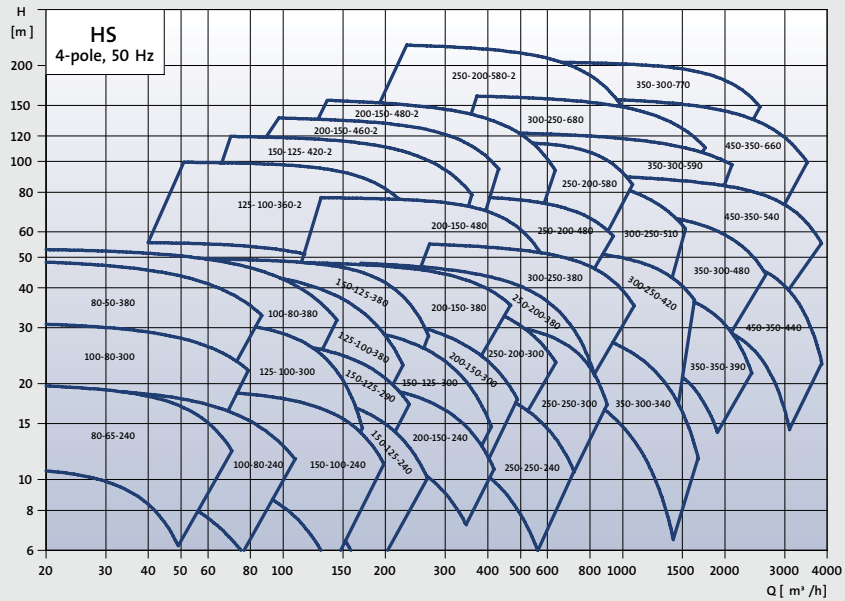

### Technical data

Flow, Q: max. 720 m³/h

Head, H: max. 220 m

Liquid temp.: 5°C to +70°C

Operat. pres.: max. 16 bar



## Grundfos NB / NK

- End-suction centrifugal pumps



*The robust design of the Grundfos NK range secures reliable operation and long life*

### **Constant pressure for large-scale systems**

The Grundfos end-suction pumps are especially suitable for water distribution in large-scale irrigation systems. The heavy-duty allrounders offer extreme volume and reliable operation under tough working conditions.

Furthermore, the horizontal construction of the pump allows easy dismantling of the pump and the “back pull-out” design guarantees easy and uncomplicated service.

### **Features**

- Standard dimensions according to EN or ISO standards
- Wide range
- Robust design
- Heavy-duty
- Flexible motor range

## Performance curves

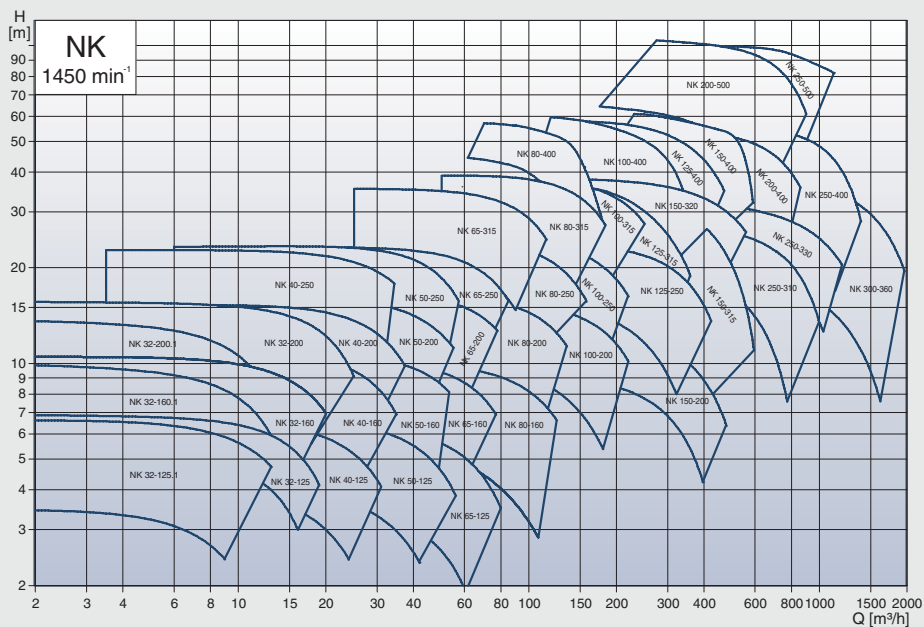

### Technical data

Flow, Q: max. 2000 m<sup>3</sup>/h

Head, H: max. 150 m

Liquid temp.: -25°C to +140°C

Operat. pres.: max. 16 bar

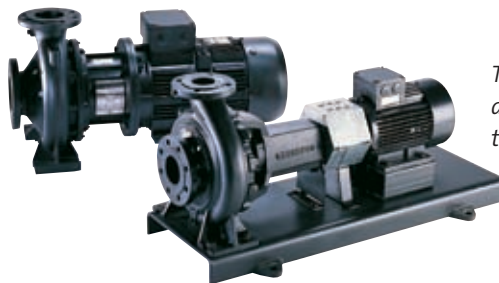

*The wide range of motor sizes allows you to fit the Grundfos NK/NB to your specific requirements*

## Grundfos BM / BMB

### - 4", 6", and 8" Booster Modules

#### Exceptional boosting in every respect

Because every component of the Grundfos BM is built into a high-quality stainless steel sleeve, it is completely covered from possible damaging elements. Consequently, the booster module can be buried in the ground or installed out in the open, depending on your specific requirements.

Sheltered from any outside influence, the Grundfos BM range is never exposed to wear and is therefore completely maintenance-free. This entails reliable and energy-efficient operation, extremely long life, and no leakage thanks to the absence of a shaft seal.



*Make an underground installation or leave it out in the open. Once it is installed you need not worry about the Grundfos BM for many, many years*

#### Features

- Integrated dry-running protection
- Soft start
- Over and undervoltage protection
- High efficiency

## Performance curves

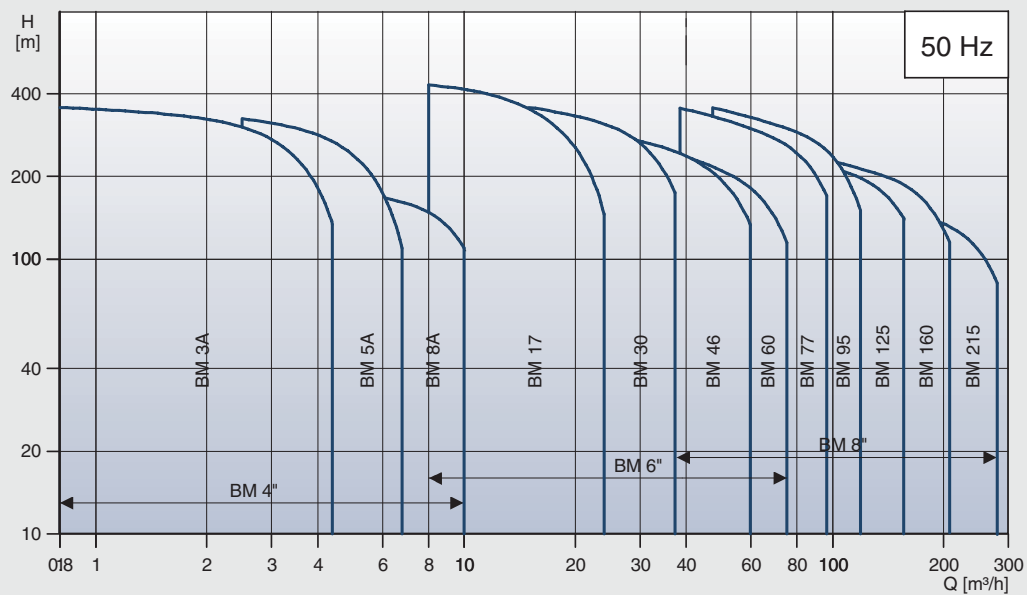

### Technical data

Flow, Q: max. 300 m<sup>3</sup>/h  
 Head, H: max. 80 bar  
 Liquid temp.: 0°C to +60°C  
 Installation depth: max. 150 m



*The Grundfos BM comes in a wide range of models to meet your every requirement*

## Grundfos DME / DMS

### - Compact diaphragm dosing pumps



*The Grundfos dosing range consists of two motor variants. The DME series comes with a variable-speed motor. The DMS variants use synchronous motors that run at constant speed, stopping only between cycles*

#### **Precise fertigation**

The application of nutrients through irrigation systems is called “fertigation,” a contraction of fertilisation and irrigation. The most common nutrient applied by fertigation is nitrogen. Elements applied less often include phosphorus, potassium, sulfur, zinc, and iron.

Grundfos diaphragm dosing range is ideal for fertigation because it is resistant to highly corrosive chemicals, and at the same time able to inject extremely precise amounts of fertiliser. Furthermore, a Grundfos dosing solution secures optimal mixing of fertilizer in the water line and is not affected by changes in water pressure, which, combined with precision, secures precise and uniform irrigation.

#### **Features**

- Precise capacity setting in ml or l
- Full diaphragm control
- Stroke speed or frequency capacity control
- Proportional dosing
- Operation panel with display and one-touch buttons
- Front or side-fitted operation panel
- Manual, pulse, and analog control
- Pulse/timer-based batch control



## Performance curves

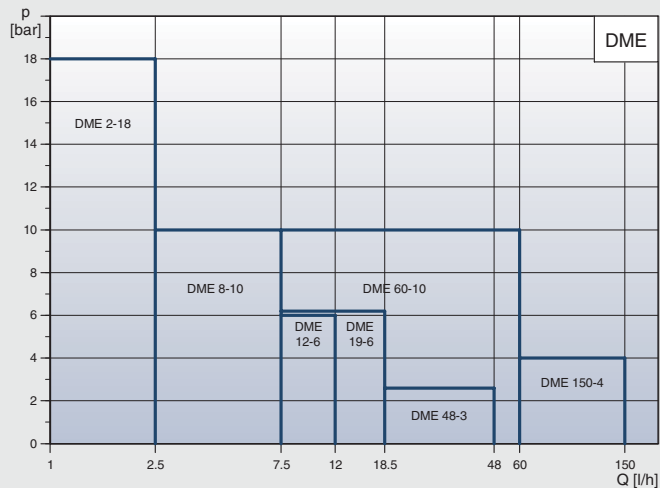
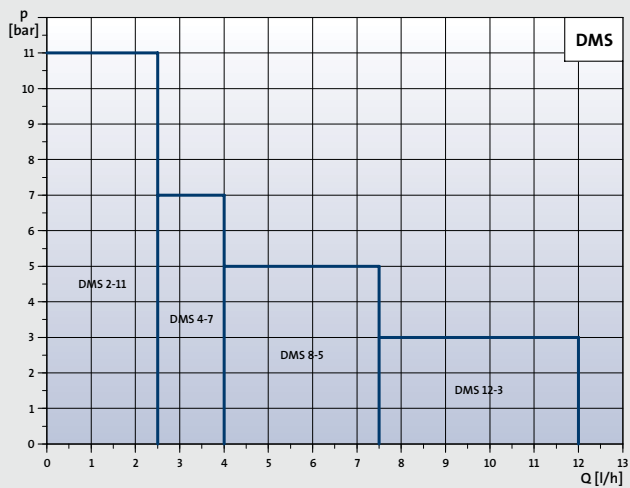

### Technical data

Capacity, Q: max. 150 l/h  
 Pressure, p: max. 18 bar  
 Liquid temp.: max. +50°C



## 7. About Grundfos

With manufacturing facilities around the globe and an annual production of more than 10 million pumps, Grundfos is one of the world's largest pump manufacturers.

### **Expert assistance**

We can assist you through every stage of the irrigation process: from the initial planning stages through implementation and installation to service and maintenance. We are specialists; it is our business to know all there is to know about pumping. But our specialised knowledge also gives us breadth of vision – knowing what can be done enables us to see potential solutions. All solutions are as energy-efficient and mechanically reliable as possible, and often customised to match your specific demands.

### **Full-line supplier**

In addition to our wide range of quality pumps for irrigation, we offer solutions within fire protection, heating, air conditioning, water supply, sanitary processes, wastewater, dosing, and industrial applications.

### **Global presence**

Grundfos has a highly efficient worldwide organisation of sales, support, and service professionals. With more than 13,000 employees in 67 Grundfos companies in over 40 countries, we are never far away. Wherever you are based, you can always get in touch with us for advice and assistance, and spare parts are readily available.

The Grundfos Group invests heavily in R&D to be able to constantly introduce groundbreaking products with increased capabilities and high quality performance. Quality is a key component in all Grundfos products, which implies a constant focus on construction, design, and choice of materials and processes. Grundfos companies are registered according to the environmental standard of ISO 14001 and the European EMAS.

**For more information about our wide range of pump solutions, please visit:  
[www.grundfos.com](http://www.grundfos.com)**



*A small selection of pumps for a wide range of applications*



**BE > THINK > INNOVATE >**

Being responsible is our foundation  
Thinking ahead makes it possible  
Innovation is the essence

[www.grundfos.com](http://www.grundfos.com)

**GRUNDFOS** 

96 59 24 42 04 07