

INSTRUCTION AND REPAIR MANUAL

SPHER-FLO

Model
611A

ENGLISH: PAGES 2-8

INSTRUCTION AND REPAIR MANUAL

NOTE! To the installer: Please make sure you provide this manual to the owner of the equipment or to the responsible party who maintains the system.



CALIFORNIA PROPOSITION 65 WARNING:

▲ WARNING This product and related accessories contain chemicals known to the State of California to cause cancer, birth defects or other reproductive harm.

SERVICE

Your Aurora pump requires no maintenance other than periodic inspection, lubrication and occasional cleaning. The intent of inspection is to prevent breakdown, thus obtaining optimum service life.

LUBRICATION OF BEARINGS

Regreasable bearings will require periodic lubrication and this can be accomplished by using the zerk or lubrication fitting at each bearing. Lubricate the bearings at regular intervals using high quality grease. The initial bearing lubrication at Aurora is Chevron SRI Grease NLGI 2 (polyurea thickener) (Pentair Part Number 384-0002-639). Before lubricating the bearings, thoroughly flushing the old grease with the new grease is required. We recommend Chevron SRI Grease NLGI 2 (polyurea thickener) for follow-up relubrication after the flushing. Most major brands of Grade No. 2 ball bearing grease are satisfactory for pump operation in both wet and dry applications.

CAUTION

Be aware that mixing of different brands or blends of grease should be avoided due to possible incompatibilities that could damage the bearings. A thorough flushing of the old grease with the new grease is required to minimize this potential incompatibility. Avoid using the following: (1) grease of vegetable or animal base that can develop acids or (2) grease containing rosin, graphite, talc or other impurities. Under no circumstances should grease be reused.

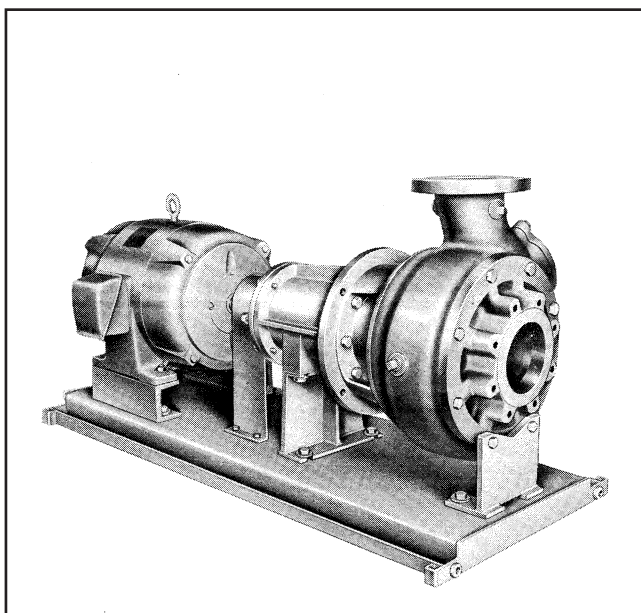

CAUTION

Over lubrication should be avoided as it may result in overheating and possible bearing failure. Under normal application, adequate lubrication is assured if the amount of grease is maintained at 1/3 to 1/2 the capacity of the bearing and adjacent space surrounding the bearing.

In dry locations, each bearing will need lubrication at least every 4,000 hours of running time or every 6 to 12 months, whichever is more frequent. In wet locations the bearings will need lubrication at least after every 2,000 hours of running time or every 4 to 6 months, whichever is more frequent. A unit is considered to be installed in a wet location if the pump and motor are exposed to dripping water, to the weather, or to heavy condensation such as found in unheated and poorly ventilated underground locations.

The 5E, 5F, 5G, 5H, 6D and 6E bearing frames have back-to-back angular contact bearings as the outboard thrust bearing (50). This style bearing requires more frequent lubrication intervals. It is suggested that it be lubricated every 1,000 hours of running time.

The 4D, 5F, 5H, 6D and 6E power frames have a spherical roller bearing as the inboard radial bearing (49). This style bearing requires lubrication every 500 hours.

At times it may be necessary to clean the bearings due to accumulated dirt or deteriorated lubricants. This can be accomplished by flushing the bearing with a light oil heated to 180 to 200°F. While rotating it on a spindle, wipe the bearing housing with a clean rag soaked in a cleaning solvent and flush all surfaces.

Dry the bearing thoroughly before relubricating. Compressed air can be used to speed drying, but care should be taken not to let bearings rotate while being dried.

CAUTION

Use normal fire caution procedures when using any petroleum cleaner.

The motor that drives your Aurora pump may or may not require lubrication. Consult the manufacturer's recommendations for proper maintenance instructions.

REPAIRS

The pump may be disassembled using the illustrations and text provided. Although complete disassembly is covered, it

will seldom be necessary to completely disassemble your Aurora pump.

The illustration accompanying the disassembly instructions shows an exploded view of the pump. The illustration is intended to aid in the correct identification of the parts mentioned in the text.

Inspect parts removed at disassembly to determine their reusability. Cracked castings should never be reused. All packing and gaskets should be replaced at reassembly simply as a matter of economy—they are much less expensive to replace routinely than to replace as the need occurs. In general, it is economical to return the motor and motor controller to the manufacturer for repair.

SPHER-FLOW MODELS 611A DISASSEMBLY

This pump has been designed with back pull-out features, which allow the frame and rotating element to be removed without disturbing the suction and discharge piping.

1. Disconnect power so that drive unit cannot be accidentally energized during disassembly.

2. Close all valves or flow devices that control movement of liquids to or from the pump. Drain pump by removing drain plug (70) from suction nozzle (65). Remove any flushing, lubrication, pressurization, venting, drain or cooling lines from pump. Remove handhole cover (19) and gasket (18) from casing by removing capscrews (20).

3. Loosen capscrews from each hub of spacer-type coupling and remove coupling flanges and rubber insert. This leaves a 3-1/2 in. space between end of motor shaft and pump shaft to facilitate back pull-out of pump.

4. Remove capscrew (34) that holds casing (1) to bracket (8). With the aid of a rope sling and a crane or hoist, carefully slide power frame and rotating element away from casing.

5. Remove gasket (17) from its position between bracket (8) and casing (1). Inspect the sealing surface to insure that it is clean and free of any gasket material that has stuck to parting surfaces. Replace this gasket with a new one when pump is reassembled. Remove capscrews (23) and remove support (22) and washers (24).

6. Inspect casing and impeller wearing rings (3 & 6) (optional) and replace if necessary. Removal can be accomplished by removing capscrews (4 & 7).

7. Remove capscrew (10), o-ring gasket (11), washer (12) gasket (13), which allow impeller (2), key (14), and gasket (38) to be removed.

NOTE

Spher-Flo Pumps have a tapered hub impeller to facilitate impeller removal. Use caution in removal of impeller as it only has to be moved a few thousandths of an inch to become entirely free.

The easiest method for removing impeller is to suspend entire power frame and rotating element about 1/32 of an inch above floor or work area.

Eyebolt size is:

- Power Frames 4C and 4D require 5/8-11NC eyebolt.
- Power Frames 5E and 5F require 3/4-10NC eyebolt.
- Power Frames 5G, 5H, 6D and 6E require 1-8NC eyebolt.

Apply pressure to impeller by means of jackscrews (60 and 61) located on bearing cap (51). When impeller is firmly against bracket (8) it should drop free after turning the jackscrews evenly, a flat at a time, three or four flats.

8. Insure external retaining ring (snap ring, 39) is located in

the groove on the inboard side of the shaft sleeve. Unscrew capscrews (34) to allow removal of stuffing box (27), shaft sleeve (36), gland (44) and seal or packing (47, 40).

NOTE

The shaft sleeve incorporates a snap ring designed to interfere with the base of the seal box assembly. When removing the stuffing box the shaft sleeve is also removed.

Slide complete assembly including shaft sleeve (36) off the shaft (48) with the aid of a pinch bar or other lever. Place the stuffing box assembly on a suitable work surface for further disassembly.

For further disassembly of the stuffing box proceed as follows:

a. Packing box (Standard)

Remove cap screws (45), and split accumulator gland halves (44) from stuffing box. Slinger (43) is now exposed and can be removed from shaft sleeve. Remove O-ring gasket (42) from the stuffing box. Remove and discard old packing (40). Clean all parts to remove any packing that may have adhered during removal. Leakage accumulator gland (44) on vertical units, may be further disassembled by moving cap screws (44A), pipe plugs (44D), tubing (44C) and hose connectors (44B).

B. Double Seal (optional).

1. Remove seal gland bolts (45) and remove gland (44) carefully exposing seal (47).

2. Stationary insert can now be carefully pressed out of the gland (44).

3. The exposed outboard seal ring in the stuffing box may be removed at this time if seal O-ring has not locked it into place. Do not attempt to pry the rotating face out of the stuffing box, leave rotating face in place if it cannot be readily removed. Liberally apply either a commercial mechanical seal lubricant or a non-abrasive liquid dish washing soap to the seal/shaft sleeve area.

4. Press the shaft sleeve (36), pressing from the outboard end of the sleeve, out of the stuffing box (27). Care should be taken to protect the rotating face from damage if the O-ring under the face should break loose and spring pressure force the face upward.

5. The stationary insert can now be carefully pressed out of the stuffing box (27).

The retaining ring (37) can be removed from the groove in the shaft by twisting it in a spiral movement toward the end of the shaft. Remove grease seal (53).

11. Remove capscrews (59) and lift out shaft assembly from the power frame.

12. The inboard radial bearing is either a ball bearing or spherical roller bearing design and can be identified by power frame as listed below.

4C, 5E, 5G power frames use a ball bearing.

4D, 5F, 5H, 6D and 6E use a spherical roller bearing.

13. Remove coupling half and key (55) from shaft. Remove plug (57) and zerk fitting (58).

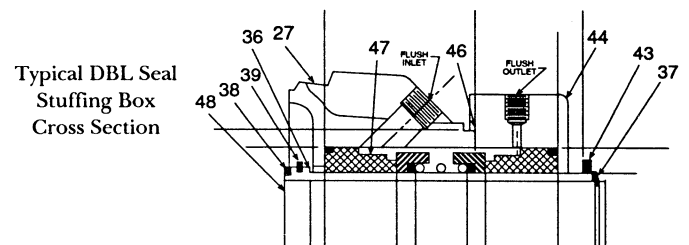

14. Retainer ring (50B) is removed with a pair of truarc internal pliers so that grease retainer (50A) can be removed allowing bearing cap (51) to be removed from shaft assembly. Grease seal (52) may be removed if necessary.

15. With a pair of truarc external pliers, remove snap ring (50C) (PF#4 only), or remove locknut (50D) and lockwasher (50C) on power frame(s) #5, and #6.

16. Both inboard bearing (49) and outboard bearing (50) are pressed onto shaft. To remove bearings, use a wheel puller or press them off the shaft.

NOTE

When removing the inboard bearing (49), avoid damaging the separate grease shield (49A). This shield can be removed when bearing is removed from shaft.

17. If total disassembly is required, break connections to suction and discharge pipe and remove capscrews that hold support (21) to pump base.

18. Secure casing and support assembly in sling and move it away from piping. Invert this assembly and set casing (1) on wood blocks, so as not to mar surface that mates bracket (8).

19. Unscrew capscrews (69), washers (69B), and nuts (69A), and remove handhole cover (68) and gasket (67) from suction nozzle (65).

20. Place rope sling through nozzle and cover opening. Remove capscrews (66) and lift suction nozzle (65) away from cover (5). Remove gasket (64).

21. Unscrew capscrews (15 & 15A), which hold support (21), cover (5) and casing (1) together. Lift support away and then set casing with discharge up. Gently tap cover loose with a rubber mallet. Remove gasket (16) to complete disassembly.

SPHER-FLOW MODEL 611A REASSEMBLY

These instructions are for a pump that has been completely disassembled. Use those parts that apply to your reassembly program.

1. Place casing (1) with its outboard side down and position gasket (16) in place. Set cover (5) in place so the gasket position is neither lost nor damaged. Next align support (21) on cover. Use care not to disturb location of other parts. When all the above parts have been aligned, they are fastened together with capscrews (15 & 15A). Tighten capscrews evenly to insure perfect register of mating parts. Replace pipe plugs (25) and (26) in casing.

2. Position gasket (64) on cover and carefully lower suction nozzle (65) into place. Fasten suction nozzle in place with capscrews (66).

3. Slip gasket (67) onto shoulder of handhole cover (68) and secure it to suction nozzle (65) with capscrews (69), washer (69B) and nuts (69A). Place drain plug (70) back into suction nozzle.

4. Return casing and support assembly to its normal position. Fasten suction and discharge piping to pump. Secure this assembly in place by tightening nuts on found-

ation bolts. If pump has wearing rings (6), fasten it to cover (5) with screws (7). If handhole cover (19) was removed, place gasket (18) on cover and secure with capscrews (20).

5. Hand pack the outboard bearing (50) with grease and pack the grease retainer (50A) cavity half full. Slide the grease retainer onto the shaft. Press the outboard bearing onto the shaft until it hits the shoulder of the shaft. Make sure the outboard bearing set is properly matched with back-to-back configuration before pressing on shaft. Assemble snap ring (50C) onto the shaft with the beveled side outward to match the bevel in the shaft groove (PF#4 only). Install lockwasher (50C) and locknut (50D) to secure outboard bearing (50) to shaft (48) for P.F. #5 and 6. Torque to approximately 100 ft. lbs. Press or gently tap grease seal (52) into bearing cap (51). Slide the bearing cap (51) over the bearings. Lock in the assembly with snap ring (50B), matching the snap ring bevel to the groove bevel.

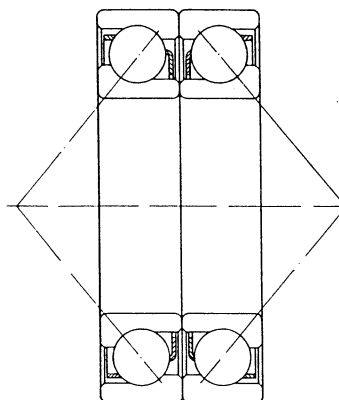

Back-to-Back
Bearing Configuration

6. Hand pack the inboard bearing (49) and the recessed area of its grease shield (49A). Slide the grease shield onto the shaft with the raised lip toward the bearing. Press on the bearing. Press the bearing on until all parts are shouldered tight together on the shaft. The grease shield may wear into the bearing outer race during break-in and is considered normal.

7. Place grease seal (53) into place on inboard end of power frame (56).

8. Lower the sub-assembly from steps 5 through 7 into outboard end of power frame (56), which has been set on a bench with a hole in it to accommodate the shaft.

9. Position jack screws (60) so that they extend past the bearing cap as given in the following chart. This will position the impeller hub end of the shaft in a axial position that will allow the mounting of impeller and closing down of liquid end without any adjustment during the intermediate assembly step. Final adjustment will have to made by evenly tightening capscrews (59).

	Gap Clearance	Bolt Extension
Power Frame #4	1/8 in.	1/4 in.
Power Frame #5	1/4 in.	9/16 in.
Power Frame #6	1/4 in.	9/16 in.

10. Place plug (57) and zerk (58) back in bearing cap (51).

11. Place plug (62) and zerk (63 or 62A) back on inboard end of power frame (56).

12. Retaining ring (37) can be set in its groove by turning it in a spiral motion up shaft. When in position, the outside diameter of this ring should slope toward inboard tapered shank end of shaft.

13. Position bracket (8) to power frame (56) and secure in place by evenly tightening capscrews (35).

14. The following procedure is used in assembling the appropriate sealing box:

A. Packing Box (Standard)

- I. Place two pieces of packing (40) into the stuffing box cavity (27) being careful to get each piece firmly in place. Install lantern ring (41), then add remaining three pieces of packing. When packing is tightened, lantern ring should align with holes for bushing (29), flushing lines, or cooling lines.

NOTE

Be sure to stagger joints of packing rings to avoid excessive leakage.

- II. Replace bushing (29) and grease zerk (30) in body of stuffing box (27).
- III. Snap retainer ring (39) onto shaft sleeve (36) with a pair of truarc external snap ring pliers. Slide shaft sleeve carefully into inboard end of packing box.
- IV. Thread capscrews (45) into stuffing box (27) approximately ¼ in. Insert both halves of gland (44) into stuffing box (27). Insert gland clamps (44E) and tighten packing adjusting capscrews (45) to obtain proper sealing.
- V. Ensure capscrews (45) are now tightened enough to hold assembled gland in place. Final adjustment of packing box will have to be made after pump is returned to operation.

When pump is running, gland capscrews (45) should be evenly turned down a flat at a time, allowing packing to work in until a leakage rate of approximately 60 to 120 drops per minute is obtained.

NOTE

Do not over tighten packing as this will cause packing box to overheat and the shaft sleeve (36) to wear excessively.

- VI. Place gasket (38) in radial corner groove that is machined on the end of the shaft sleeve (36) to complete assembly.

B. Double Seal Box (Optional)

NOTE

Do not put mechanical seal back into service until seal ring and stationary seat faces have been relapped or replaced.

- I. Thoroughly inspect the seal box cavity (27), checking for burrs or nicks, which could damage the o-ring of the mechanical seal. Apply a film of liquid dishwashing detergent or rubber lubricant (do not use oil or grease) to the O-ring and seal seat. Press one stationary seat with O-ring gently into the seal box cavity (27) and other into the gland plate (44).

- II. Place gasket (46) in position in the gland register.
- III. Snap retaining ring (39) onto sleeve (36) with a pair of truarc external pliers.
- IV. Slide sleeve through bottom of stuffing box and place one seal ring (47) over sleeve and slide it down to the stationary seat. Place metal parts over shaft and then second seal ring.
- V. Position gland over shaft sleeve and fasten to seal box with capscrews (45).

15. Place gasket (32) in groove of bracket (8).

16. Place key (54) in its keyway on shaft. Slide stuffing box assembly onto shaft, so that key and keyway in the shaft sleeve mate. Continue to slide assembly forward until shaft sleeve is in contact with retaining ring (37).

17. Align seal box (27) with gasket (32) and bracket (8). Fasten seal box to bracket with capscrews (33).

18. If pump has impeller wearing ring (3) fasten it to suction face of impeller (2) with setcrews (4).

19. Place impeller key (14) in keyway on the tapered portion of shaft (48) and set impeller (2) in position. Put gasket (13) inside impeller suction eye washer (12) next and o-ring gasket (11) last. Secure impeller in place with capscrew (10) according to the following chart.

IMPELLER BOLT TORQUE

Power Frame	Impeller Bolt Size	Torque Value
4C, 4D	¾ in.	75 FT-LBS
5E, 5F	¾ in.	100 FT-LBS
5G, 5H	1 in.	100 FT-LBS
6D, 6E	1 in.	125 FT-LBS

20. Place gasket (17) on casing (1) and lower power frame (56) and rotating element assembly into place; fasten this assembly to casing with capscrews (34).

Attach support (22) to power frame (56) with capscrews (23) and washers (24). Remove eyebolt assembly and place a rope sling on assembly. Carefully lower assembly to a horizontal position.

21. Using jackscrews (60) and nuts (61) located on bearing cap (51), adjust impeller and shaft assembly axially down until impeller bottoms out on its suction cover (5) or wearing rings (3) and (6). Then, loosen capscrews (59) and turn jacking screws (60) inward 3 or 4 flats to raise impeller to running clearance of .015/.025. Tighten jam nuts (61) and capscrews (59) to lock in adjustment.

NOTE

22. Make one last check that all parts of the rotating element turn freely. Return spacer coupling between pump and motor using key (55).

23. Connect any flushing lines or cooling lines that were removed.

24. Open all valves or flow devices that control flow of liquid to and from pump.

25. Connect power.

Do not start up a pump until all air and vapor have been bled, making sure that there is liquid in the pump to provide the necessary lubrication. It is possible that the mechanical seal may drip during the first few minutes of operation.

Turn on power momentarily to check for proper rotation. Rotation should be clockwise as viewed from driver (see arrow on casing).

MODEL 611A LIST OF PARTS

1. Casing	27D. Pin	50. Outboard Bearing	69A. Nut
2. Impeller	27E. Capscrews	50A. Grease Shield	69B. Washer
3. Wear Ring	27F. Capscrew	50B Retaining Ring or	70. Pipe Plug
4. Set Screw	28. Pipe Plug	Capscrew	72. Drive Pins
5. Suction Cover	29. Bushing	50C. Lockwasher or Retaining Ring	73. Name Plate
6. Wear Ring	30. Fitting	50D. Locknut	
7. Set Screw	31. Pipe Plug	50E. Washers	
8. Bracket	31A. Pipe Coupling	51. Bearing Cartridge	
10. Imp. Bolt	31B. Nipple	52. Grease Seal	
11. Imp. Bolt Seal	32. Gasket	53. Grease Seal	
12. Imp. Washer	33. Capscrew	54. Sleeve Key	
13. Imp. Washer Gasket	34. Capscrew	55. Shaft Key	
14. Impeller Key	35. Capscrew	56. Power Frame	
15. Capscrew	36. Sleeve	57. Pipe Plug	
15A. Capscrew	36A. Sleeve Adapter	58. Grease Fitting	
16. Gasket	37. Retaining Ring	59. Capscrew	
17. Gasket	38. Gasket	60. Capscrew	
18. Gasket	39. Retaining Ring	61. Jam Nut	
19. Handhole Cover	39A. O-Ring	62. Pipe Plug	
20. Capscrew	40. Packing	62A. Fitting Grease	
21. Pump Support	41. Lantern Ring		
22. Pump Support	43. Slinger	63. Grease Fitting or	
23. Capscrew	44. Gland	Pipe Plug	
24. Washer	44E. Gland Clamp	64. Gasket	
25. Pipe Plug	45. Capscrew	65. Suction Nozzle	
26. Pipe Plug	46. Gasket	66. Capscrew	
27. Stuffing Box	47. Mechanical Seal	67. Gasket	
27A. Adapter Plate	48. Shaft	68. Handhole Cover	
27B. Split Packing Box	49. Inboard Bearing	69. Capscrew	
27C. Gasket	49A. Grease Shield		

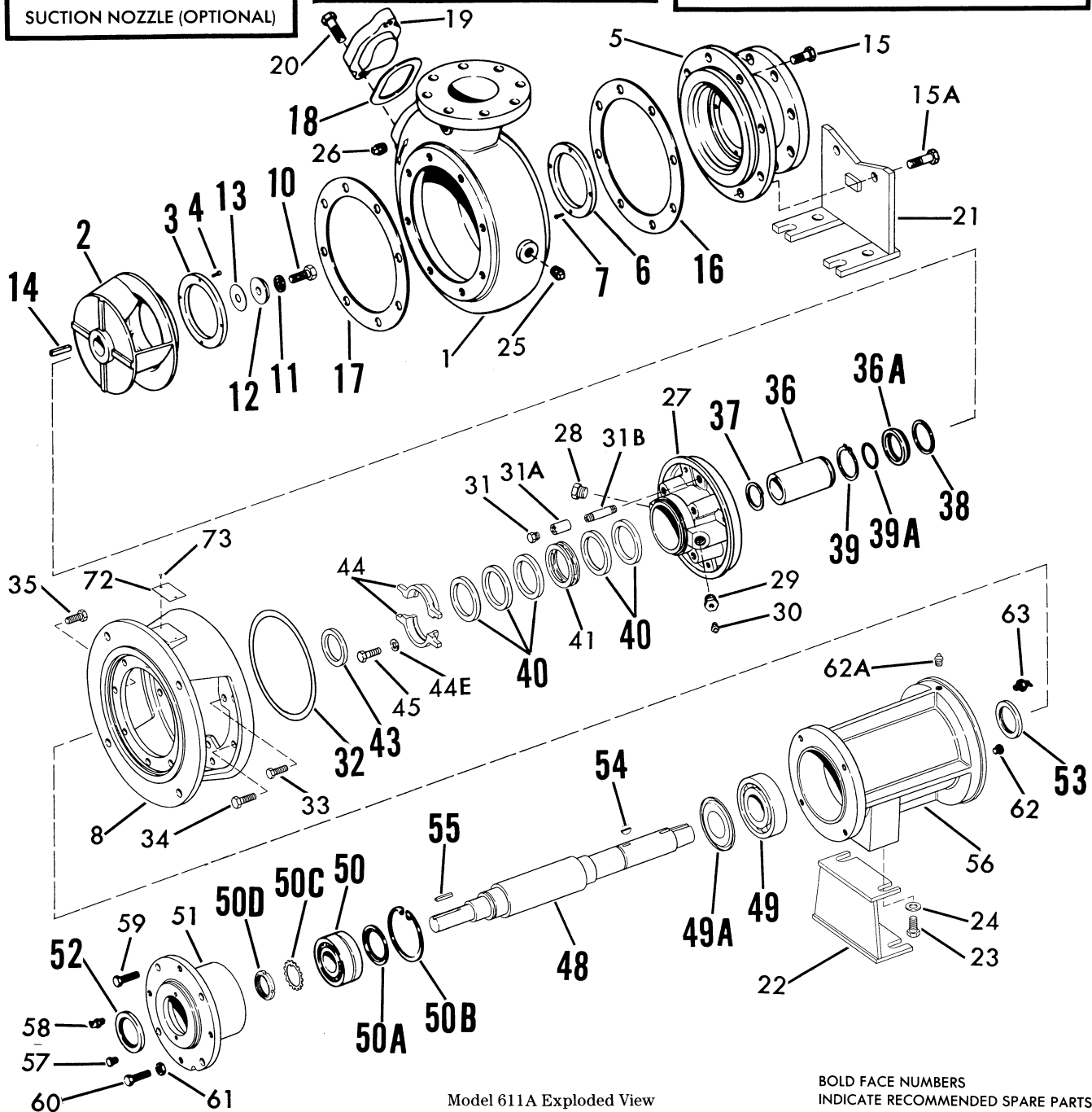
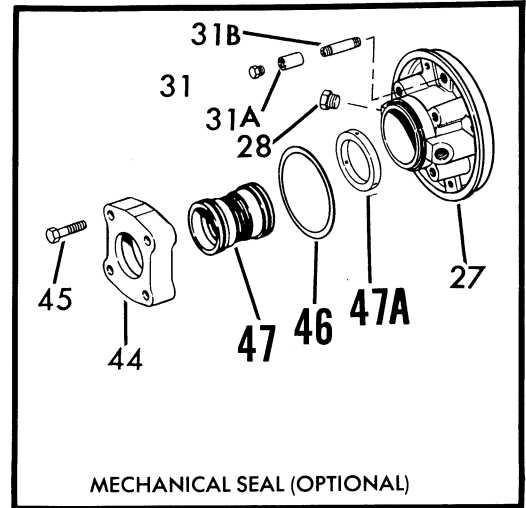
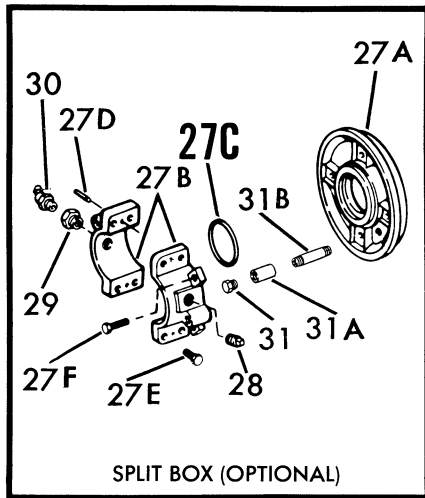
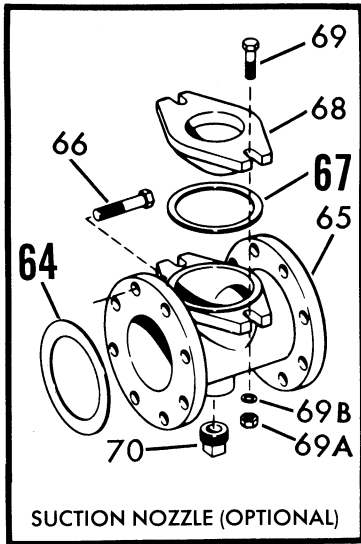

Model 611A Exploded View

BOLD FACE NUMBERS
INDICATE RECOMMENDED SPARE PARTS.

WARRANTY

Seller warrants equipment (and its component parts) of its own manufacture against defects in materials and workmanship under normal use and service for one (1) year from the date of installation or start-up, or for eighteen (18) months after the date of shipment, whichever occurs first. Seller does not warrant accessories or components that are not manufactured by Seller; however, to the extent possible, Seller agrees to assign to Buyer its rights under the original manufacturer's warranty, without recourse to Seller. Buyer must give Seller notice in writing of any alleged defect covered by this warranty (together with all identifying details, including the serial number, the type of equipment, and the date of purchase) within thirty (30) days of the discovery of such defect during the warranty period. No claim made more than 30 days after the expiration of the warranty period shall be valid. Guarantees of performance and warranties are based on the use of original equipment manufactured (OEM) replacement parts. Seller assumes no responsibility or liability if alterations, non-authorized design modifications and/or non-OEM replacement parts are incorporated. If requested by Seller, any equipment (or its component parts) must be promptly returned to Seller prior to any attempted repair, or sent to an authorized service station designated by Seller, and Buyer shall prepay all shipping expenses. Seller shall not be liable for any loss or damage to goods in transit, nor will any warranty claim be valid unless the returned goods are received intact and undamaged as a result of shipment. Repaired or replaced material returned to customer will be shipped F.O.B., Seller's factory. Seller will not give Buyer credit for parts or equipment returned to Seller, and will not accept delivery of any such parts or equipment, unless Buyer has obtained Seller's approval in writing. The warranty extends to repaired or replaced parts of Seller's manufacture for ninety (90) days or for the remainder of the original warranty period applicable to the equipment or parts being repaired or replaced, whichever is greater. This warranty applies to the repaired or replaced part and is not extended to the product or any other component of the product being repaired. Repair parts of its own manufacture sold after the original warranty period are warranted for a period of one (1) year from shipment against defects in materials and workmanship under normal use and service. This warranty applies to the replacement part only and is not extended to the product or any other component of the product being repaired. Seller may substitute new equipment or improve part(s) of any equipment judged defective without further liability. All repairs or services performed by Seller, which are not covered by this warranty, will be charged in accordance with Seller's standard prices then in effect.

THIS WARRANTY IS THE SOLE WARRANTY OF SELLER AND SELLER HEREBY EXPRESSLY DISCLAIMS AND BUYER WAIVES ALL OTHER WARRANTIES EXPRESSED, IMPLIED IN LAW OR IMPLIED IN FACT, INCLUDING ANY WARRANTIES OF MERCHANTABILITY OR FITNESS FOR A PARTICULAR PURPOSE. Seller's sole obligation under this warranty shall be, at its option, to repair or replace any equipment (or its component parts) which has a defect covered by this warranty, or to refund the purchase price of such equipment or part. Under the terms of this warranty, Seller shall not be liable for (a) consequential, collateral, special or liquidated losses or damages; (b) equipment conditions caused by normal wear and tear, abnormal conditions of use, accident, neglect, or misuse of said equipment; (c) the expense of, and loss or damage caused by, repairs or alterations made by anyone other than the Seller; (d) damage caused by abrasive materials, chemicals, scale deposits, corrosion, lightning, improper voltage, mishandling, or other similar conditions; (e) any loss, damage, or expense relating to or resulting from installation, removal or reinstallation of equipment; (f) any labor costs or charges incurred in repairing or replacing defective equipment or parts, including the cost of reinstalling parts that are repaired or replaced by Seller; (g) any expense of shipment of equipment or repaired or replacement parts; or (h) any other loss, damage or expense of any nature.

The above warranty shall not apply to any equipment which may be separately covered by any alternate or special warranties.

PERFORMANCE: In the absence of Certified Pump Performance Tests, equipment performance is not warranted or guaranteed. Performance curves and other information submitted to Buyer are approximate and no warranty or guarantee shall be deemed to arise as a result of such submittal. All testing shall be done in accordance with Seller's standard policy under Hydraulic Institute procedures.

LIABILITY LIMITATIONS: Under no circumstances shall the Seller have any liability under the Order or otherwise for liquidated damages or for collateral, consequential or special damages or for loss of profits, or for actual losses or for loss of production or progress of construction, regardless of the cause of such damages or losses. In any event, Seller's aggregate total liability under the Order or otherwise shall not exceed the contract price.

ACTS OF GOD: Seller shall in no event be liable for delays in delivery of the equipment or other failures to perform caused by fires, acts of God, strikes, labor difficulties, acts of governmental or military authorities, delays in transportation or procuring materials, or causes of any kind beyond Seller's control.

COMPLIANCE WITH LAW: Seller agrees to comply with all United States laws and regulations applicable to the manufacturing of the subject equipment. Such compliance shall include: The Fair Labor Standards Acts of 1938, as amended; Equal Employment Opportunity clauses of Executive Order 11246, as amended; Occupational Safety and Health Act of 1970 and the standards promulgated thereunder, if applicable. Since compliance with the various Federal, State, and Local laws and regulations concerning occupational health and safety, pollution or local codes are affected by the use, installation and operation of the equipment and other matters over which Seller has no control, Seller assumes no responsibility for compliance with those laws and regulations, whether by way of indemnity, warranty, or otherwise. It is incumbent upon the Buyer to specify equipment which complies with local codes and ordinances.



800 Airport Road
North Aurora, Illinois 60542
630-859-7000
www.aurorapump.com