



MYERS[®]
3RH AND 3RHX
SOLIDS HANDLING WASTEWATER PUMPS
STANDARD (3RH) AND
HAZARDOUS LOCATION (3RHX)
CONSTRUCTION

MYERS® 3RH AND 3RHX

TECHNICAL INFORMATION



THE RIGHT CHOICE

MYERS 3RH and 3RHX (hazardous location) submersible wastewater pumps are the right choice when difficult to pump fibrous or stringy solids are to be expected. The 3RH/3RHX series provides smooth, vibration-free operation when operating at heads higher than peak efficiency. For use in commercial lift stations, treatment plants and industrial waste applications. MYERS offers a complete line of wastewater pumps, lift-out rail assemblies, controls and accessories to meet your needs. Call your MYERS distributor or the MYERS sales office at 419-289-1144 for more details.

PASSES STRINGY TRASH, FIBROUS WASTES, SLURRIES, AND OTHER DIFFICULT TO PUMP SOLIDS THAT STANDARD ENCLOSED OR SEMIOPEN IMPELLERS CANNOT.

- Recessed impeller design has completely open passage in volute.
- Pumping action is by Vortex; solids cannot get caught in impeller volute.
- Operates without vibration or cavitation over entire performance curve. Operates near shut-off without harming pump.

DURABLE MOTOR WILL DELIVER MANY YEARS OF RELIABLE SERVICE.

- Recessed impeller greatly increases bearing life by reducing radial load.
- Oil-filled motor for maximum heat dissipation and constant bearing lubrication.
- Heat sensor thermostats embedded in windings protect motor from overheat conditions.
- Seal leak probes warn of moisture entry; help prevent costly motor burnout.

AVAILABLE WITH OPTIONAL FM APPROVAL FOR USE IN CLASS 1, GROUPS C AND D HAZARDOUS LOCATIONS (3RHX ONLY).

Product Capabilities

Capacities To	315 gpm	19.9 lps
Heads To	100 ft.	30.4 m
Solids Handling (dia.)	2 in.	50.8 mm
Liquids Handling	raw unscreened sewage, fibrous wastewater, effluent, storm water	
Intermittent Liquid Temp.	up to 140°F	up to 60°C
Winding Insulation Temp. (Class F)	311°F	155°C
Motor Electrical Data	3450 RPM 3 – 5 HP, 200/230V, 1Ø, 60 Hz 3 – 7½ HP, 200/230/460/575V, 3Ø, 60 Hz	
Std. Third Party Approvals	CSA	
Optional Approvals	FM Class 1, Groups C & D (3RHX only)	
Acceptable pH Range	6 – 9	
Specific Gravity	.9 – 1.1	
Viscosity	28 – 35 SSU	
Horizontal Discharge Flanged Centerline	3 in. 125 lb. ANSI	76 mm

NOTE: Consult factory for applications outside of these recommendations.

Construction Materials

Motor Housing, Seal Housing, Cord Cap and Volute Case	cast iron, Class 30, ASTM A48
Recessed Impeller	ductile iron, Class 65 ASTM A536
Power Cord	SOOW, W
Control Cord	SOOW
Mechanical Seals Standard Optional	double tandem, type 21 carbon and ceramic lower tungsten, carbide
Pump, Motor Shaft	416 SST
Fasteners	300 series SST

3450 RPM PERFORMANCE CURVE

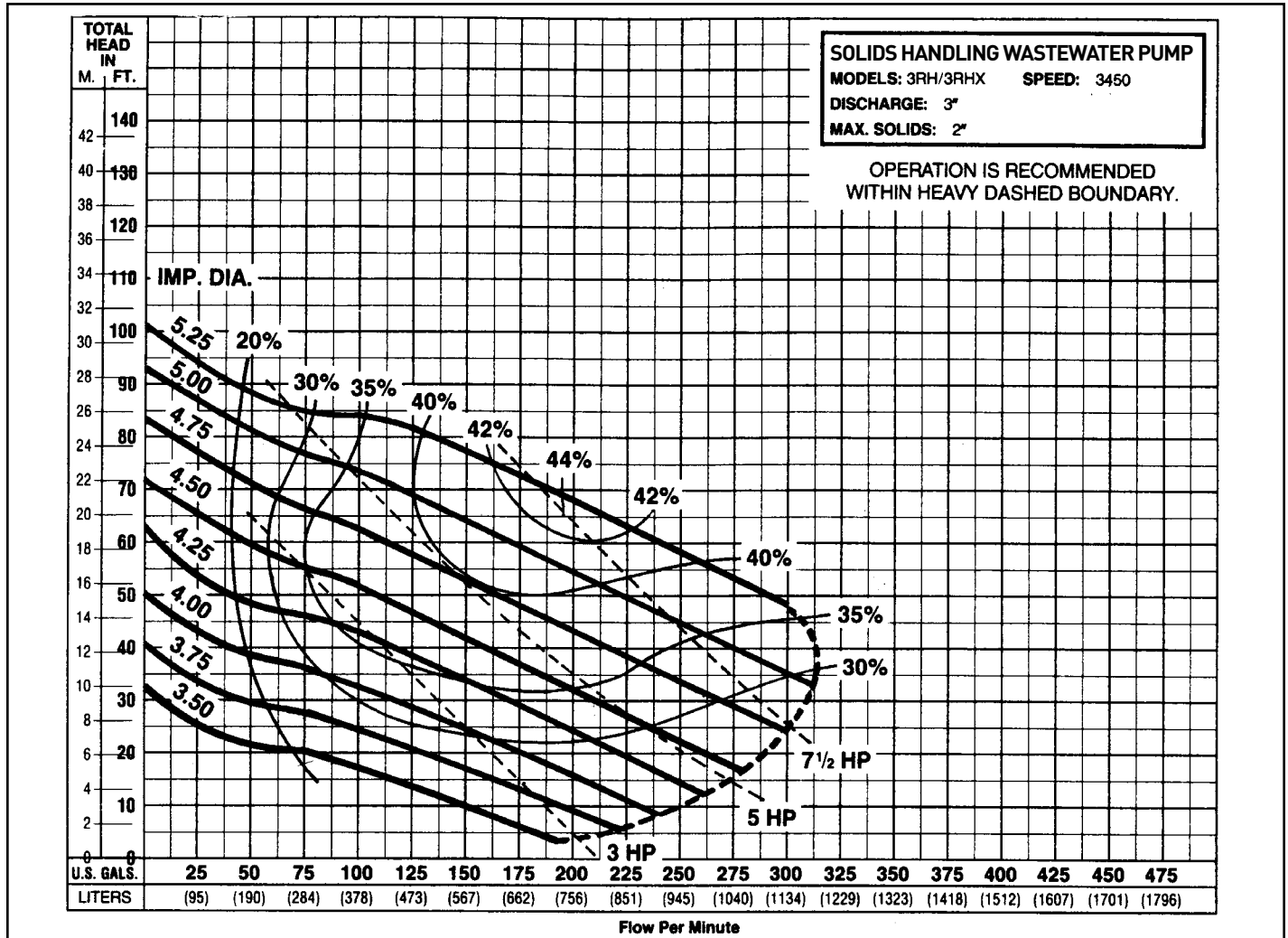

Pump performance is based on clear water (1.0 specific gravity @ 68°F) and pump fluid end (hydraulic) efficiency. Motor data based on 40°C ambient temperature.

Available Models		Motor Electrical Data												
Standard	Hazardous Location	HP	Volts	Phase	Hertz	Start Amps	Run Amps	Service Factor Amps	Run kW	Service Factor kW	Start KVA	Run KVA	NEC Code Letter	Service Factor
3RH30M2-01	3RHX30M2-01	3	208	1	60	135.0	17.9	23.8	3.5	4.6	27.0	3.6	L	1.20
3RH30M2-21	3RHX30M2-21	3	230	1	60	75.0	15.6	20.7	3.5	4.6	17.3	3.6	G	1.20
3RH30M2-03	3RHX30M2-03	3	208	3	60	66.0	9.9	13.3	3.2	4.3	22.9	2.3	J	1.20
3RH30M2-23	3RHX30M2-23	3	230	3	60	56.6	8.6	11.5	3.2	4.3	22.5	2.3	J	1.20
3RH30M2-43	3RHX30M2-43	3	460	3	60	28.3	4.3	5.8	3.2	4.3	22.5	2.3	J	1.20
3RH30M2-53	3RHX30M2-53	3	575	3	60	23.0	3.5	4.6	3.2	4.3	22.9	2.4	J	1.20
3RH50M2-01	3RHX50M2-01	5	208	1	60	135.0	29.3	33.4	5.2	5.8	27.0	5.9	F	1.20
3RH50M2-21	3RHX50M2-21	5	230	1	60	117.0	25.5	29.0	5.2	5.8	26.9	5.9	F	1.20
3RH50M2-03	3RHX50M2-03	5	208	3	60	82.0	17.0	19.1	5.2	5.9	28.4	4.0	G	1.20
3RH50M2-23	3RHX50M2-23	5	230	3	60	77.0	14.8	16.6	5.2	5.9	30.7	4.0	G	1.20
3RH50M2-43	3RHX50M2-43	5	460	3	60	38.5	7.4	8.3	5.2	5.9	30.7	4.0	G	1.20
3RH50M2-53	3RHX50M2-53	5	575	3	60	34.0	5.9	6.6	5.2	5.9	33.9	4.0	G	1.20
3RH75M2-03	3RHX75M2-03	7.5	208	3	60	211.0	23.6	31.1	7.4	9.7	73.1	5.5	L	1.31
3RH75M2-23	3RHX75M2-23	7.5	230	3	60	172.0	20.5	27.0	7.4	9.7	68.5	5.5	L	1.31
3RH75M2-43	3RHX75M2-43	7.5	460	3	60	86.0	10.3	13.5	7.4	9.7	68.5	5.5	L	1.31
3RH75M2-53	3RHX75M2-53	7.5	575	3	60	71.4	8.2	10.8	7.4	9.7	71.1	5.5	L	1.31

Motor Efficiencies and Power Factor											
HP	Phase	Service Factor Load	Motor Efficiency %				Service Factor Load	Power Factor %			
			100% Load	75% Load	50% Load	100% Load		75% Load	50% Load		
3	1	65.0	65.2	60.0	51.7	95	96	97	96		
3	3	68.8	69.3	68.9	58.4	94	94	91	86		
5	1	77.5	71.5	69.5	62.8	86	92	95	95		
5	3	75.5	71.6	67.4	61.6	89	90	87	83		
7.5	3	75.2	76.0	74.7	69.4	91	90	88	83		

ADVANTAGES BY DESIGN

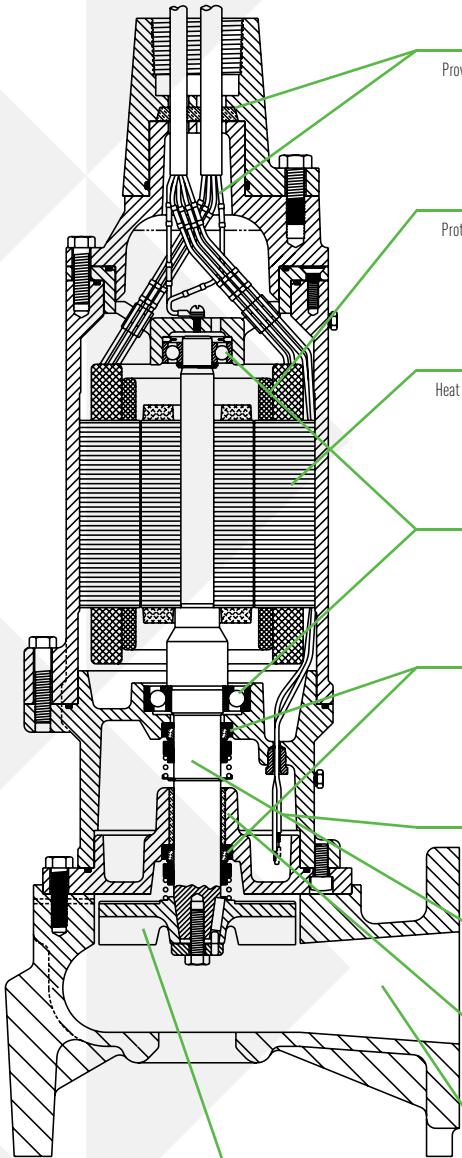

CABLE ENTRY SYSTEM

Provides double seat protection. Cable jacket seated by compression grommet. Individual wires sealed by epoxy potting.

HEAT SENSOR

Protects motor from burnout due to excessive heat from any overload condition. Automatically resets when motor has cooled.

MOTOR STATOR

Heat shrunk into housing for perfect alignment and best heat transfer. Oil-filled motor conducts heat and lubricates bearings.

BALL BEARINGS

Upper and lower ball bearings support shaft and rotor and take axial and radial loads.

SHAFT SEALS

Double tandem mechanical shaft seals protect motor. Oil-filled seal chamber provides continuous lubrication.

SEAL LEAK PROBES

Detect water in seal housing. Activate warning light in control panel.

HEAVY 416 SST SHAFT

Corrosion resistant.

SLEEVE BEARING

Takes radial shock load; provides flame path.

VOLUTE CASE

Handles 2" solids. Completely open from inlet to discharge. 3" ANSI 125 lb. flange.

RECESSED IMPELLER

Handles stringy trash and slurries without clogging or binding. Pump out vanes help keep trash from seal; reduces pressure at seal faces.

DIMENSIONS [Dimensions in mm]

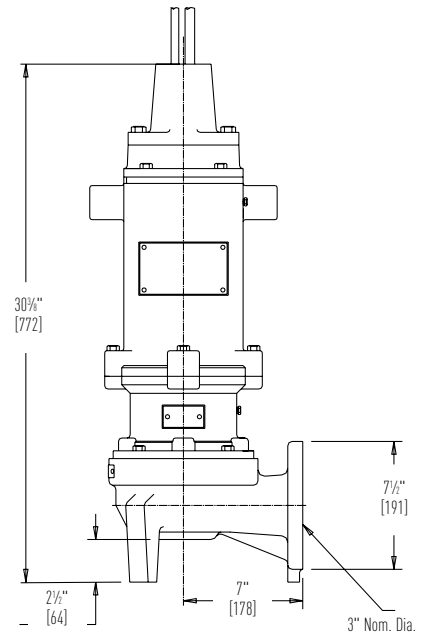
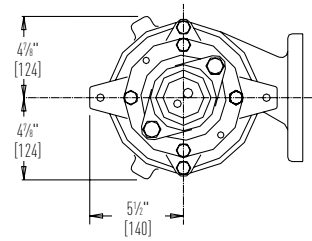

1101 MYERS PARKWAY
ASHLAND, OHIO 44805
PH: 855-274-8948
WWW.FEMYERS.COM

490 PINEBUSH ROAD, UNIT 4
CAMBRIDGE, ONTARIO, CANADA N1T 0A5
PH: 800-387-4386 ORDERS FAX: 888-606-5484
WWW.FEMYERS.COM

Because we are continuously improving our products and services, Pentair reserves the right to change specifications without prior notice.
K3437 08/07/17 © 2017 Pentair Ltd. All Rights Reserved.