

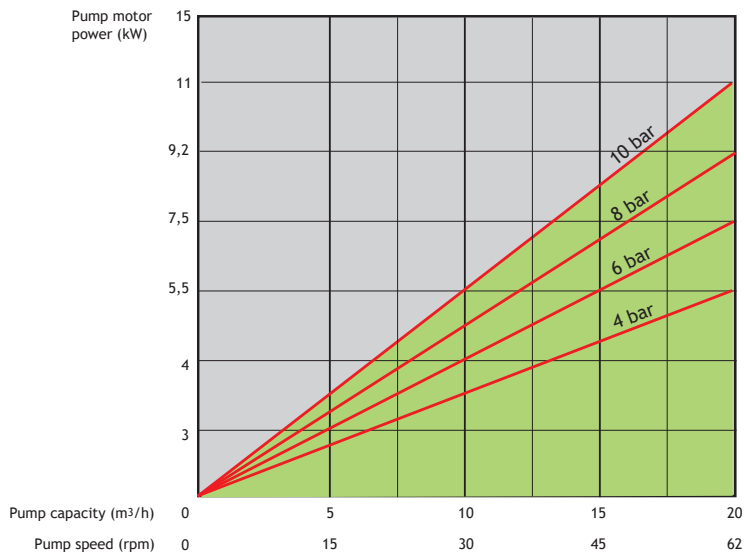

# LPP-T65 Hose Pump

## FLOW WITH MAXIMUM PRESSURE

LPP-T65 CAPACITY CHART, CONTINUOUS DUTY  
UP TO 95 °C



Continuous duty

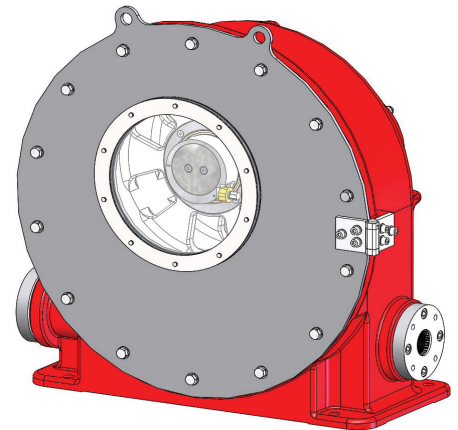

### Technical Data

- Maximum flow: 20m<sup>3</sup>/h
- Maximum pressure: 10 bar
- Flow/revolution: 5,4 l
- Hose bore: 65 mm
- Lubricant volume: 4 l
- Weight: ~960kg
- Motor power: 3 - 11 kW

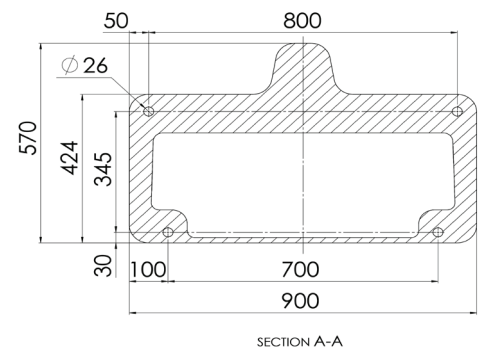
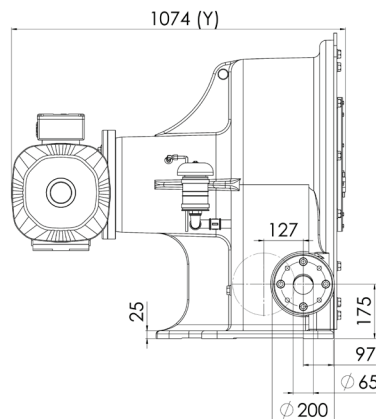
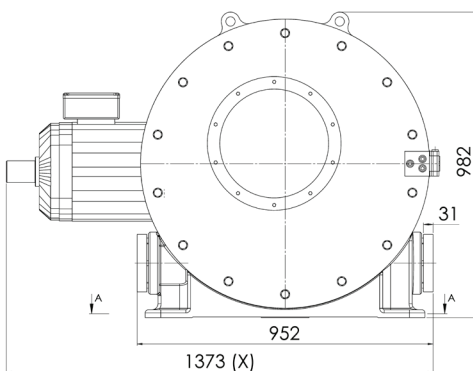

Dimensions (X, Y) vary according to the drive size.  
Please consult Flowrox for the exact drive sizing to your application.

## FLOWROX PUMP MODEL NUMBERING

Model	Size (DN)	Drive	Pressure Class (PN)	Connection	Body Material	Drive Control	Auxiliaries
LPP-T= Industrial hose pump	32 40 50 65 80 100 (mm)	GM = geared motor GU = gear unit BS = bare shaft pump	10 = 10 BAR 7.5 - 7.5 BAR (DN80)	1 = - 2 = flanged DIN PN10 3 = flanged DIN PN16 6 = flanged ANSI 150 8 = flanged B.S. TABLE D 9 = other	0 = FE	II = Integrated inverter (IP66) I = Inverter (IP20) N = None WC = Control unit	T = pressure transmitter with display R = Revolution detector D = Hose leak detector H = Connector hoses K = Connector flange for pressure transmitter F = Forced cooling

**Example:** Pump LPP-T40, geared motor, 10 bar, flanges DIN PN10, with integrated inverter, pressure transmitter with display, hose leak detector

**Type marking:** LPP-T40GM 10-2-0-II-TD

## FLOWROX PUMP HOSE MODEL NUMBERING

Hose Type	Hose Material	Pressure Class (PN)	Hose Inner Diameter (mm)
LPP-T = LPP-T pump hose	EPDM = Ethylene propylene NR = Natural rubber NBR = Nitrile NBRF = Nitrile (FDA)	10 = 10 BAR 7.5 = 7.5 BAR (DN80)	32 40 50 65 80 100

**Example:** LPP-T hose, natural rubber, pressure class 10 bar, hose bore diameter 40 mm

**Type marking:** LPP-T40-NR10

*Information without engagement. All rights to changes without prior notice reserved.*



Flowrox Oy  
P.O. Box 338  
FI-53101 Lappeenranta, Finland  
Tel. +358 201 113 311

[www.flowrox.com](http://www.flowrox.com)  
[info@flowrox.com](mailto:info@flowrox.com)

