

AURORA® MODEL 411 PUMPS

2" THRU 8" PUMPS

POWER SERIES NO. 1-2-3-4-4A

Section **410** Page **201**
Date **May 2013**

Supersedes Section 410 Page 201
Dated April 2013

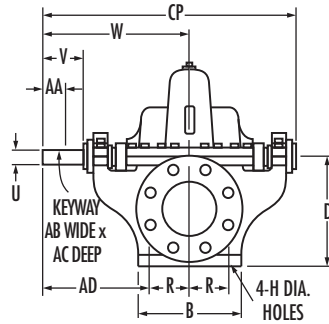

RIGHT-HAND ROTATION

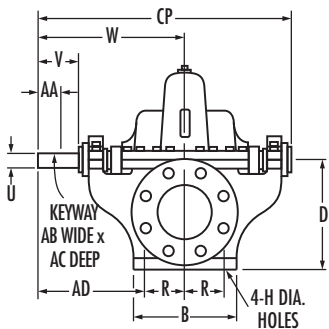
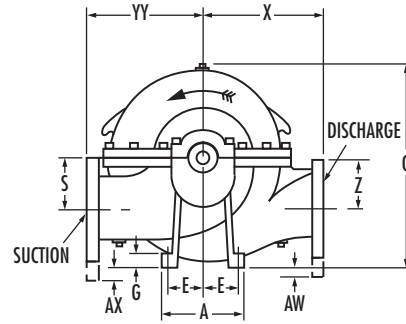

LEFT-HAND ROTATION

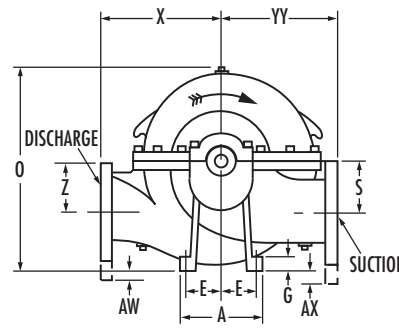

PUMP SIZE			POWER SERIES	DIMENSIONS (INCHES)																					
DISCH.	SUCT.	CASE BORE		A	B	D	E	G	H	O	R	S	U	V	W	X	Z	AA	AB	AC	AD	AW	AX	CP	YY
2	2-1/2	9	1	6-1/2 (165)	8 (203)	7 (178)	2-3/4 (70)	5/8 (16)	1/2 (13)	13-3/8 (340)	3-1/4 (83)	3-1/2 (89)	3/4 (19)	3-1/2 (89)	11-5/8 (295)	8-1/2 (216)	3-1/2 (89)	2 (51)	3/16 (5)	3/32 (2)	8-3/8 (213)	-	1/4 (6)	20-1/2 (521)	9 (229)
2	2-1/2	10	1	6-1/2 (165)	8 (203)	7 (178)	2-3/4 (70)	5/8 (16)	1/2 (13)	13-1/2 (343)	3-1/4 (83)	3-1/2 (89)	3/4 (19)	3-1/2 (89)	11-5/8 (295)	8-1/2 (216)	3-1/2 (89)	2 (51)	3/16 (5)	3/32 (2)	8-3/8 (213)	-	1/4 (6)	20-1/2 (521)	9 (229)
2	2-1/2	12	1	6-1/2 (165)	8 (203)	8 (203)	2-3/4 (70)	5/8 (16)	1/2 (13)	15-7/8 (403)	3-1/4 (83)	4 (102)	3/4 (19)	3-1/2 (89)	11-5/8 (295)	10 (254)	4 (102)	2 (51)	3/16 (5)	3/32 (2)	8-3/8 (213)	-	-	20-1/2 (521)	10-3/4 (273)
2-1/2	3	10	2	8 (203)	10 (254)	8 (203)	3-1/2 (89)	3/4 (19)	5/8 (16)	16 (406)	4 (102)	4 (102)	1-1/8 (29)	2-7/8 (73)	13-1/2 (343)	9-3/4 (248)	4 (102)	2-1/8 (54)	1/4 (6)	1/8 (3)	9-1/2 (241)	-	-	24 (610)	10 (254)
2-1/2	3	12	2	8 (203)	10 (254)	9 (229)	3-1/2 (89)	3/4 (19)	5/8 (16)	17-1/4 (438)	4 (102)	4-1/2 (114)	1-1/8 (29)	2-7/8 (73)	13-1/2 (343)	11 (343)	4-1/2 (114)	2-1/8 (54)	1/4 (6)	1/8 (3)	9-1/2 (241)	-	-	24 (610)	11-1/2 (292)
3	4	10	2	8 (203)	10 (254)	9 (229)	3-1/2 (89)	3/4 (19)	5/8 (16)	16-1/4 (413)	4 (102)	4-1/2 (114)	1-1/8 (29)	2-7/8 (73)	13-1/2 (343)	10 (254)	4-1/2 (114)	2-1/8 (54)	1/4 (6)	1/8 (3)	9-1/2 (241)	-	1/2 (13)	24 (610)	11 (343)
3	4	14	2	8 (203)	10 (254)	10 (254)	3-1/2 (89)	3/4 (19)	5/8 (16)	19-3/8 (492)	4 (102)	5 (127)	1-1/8 (29)	2-7/8 (73)	13-1/2 (343)	12 (305)	5 (127)	2-1/8 (54)	1/4 (6)	1/8 (3)	9 (241)	-	-	24 (610)	13 (330)
4	5	10	2	8 (203)	10 (254)	9 (229)	3-1/2 (89)	3/4 (19)	5/8 (16)	16-1/4 (413)	4 (102)	4-5/8 (117)	1-1/8 (29)	2-7/8 (73)	13-1/2 (343)	10 (254)	4-1/2 (114)	2-1/8 (54)	1/4 (6)	1/8 (3)	9 (241)	1/2 (13)	1-1/8 (29)	24 (610)	11-1/4 (286)
4	5	11C	3	10 (254)	12 (305)	10 (254)	4-1/4 (108)	7/8 (22)	3/4 (19)	18-3/8 (467)	5 (127)	5 (127)	1-3/8 (35)	3 (76)	14-1/2 (368)	11-1/4 (286)	5 (127)	2-3/8 (60)	3/8 (10)	3/16 (5)	9 (241)	-	1/2 (13)	26 (660)	12-3/4 (324)
4	5	11D	3	10 (254)	12 (305)	10 (254)	4-1/4 (108)	7/8 (22)	3/4 (19)	18-3/8 (467)	5 (127)	5 (127)	1-3/8 (35)	3 (76)	14-1/2 (368)	12 (305)	5 (127)	2-3/8 (60)	3/8 (10)	3/16 (5)	9 (241)	-	1/2 (13)	26 (660)	12-3/4 (324)
4	5	15	3	10 (254)	12 (305)	11 (279)	4-1/4 (108)	7/8 (22)	3/4 (19)	21-1/8 (537)	5 (127)	5-1/2 (140)	1-3/8 (35)	3 (76)	14-1/2 (368)	13 (330)	5-1/2 (140)	2-3/8 (60)	3/8 (10)	3/16 (5)	9-1/2 (241)	-	-	26 (660)	14 (356)
4	6	18	4	10 (254)	12 (305)	12-1/2 (318)	4-1/4 (108)	7/8 (22)	3/4 (19)	24-1/4 (616)	5 (127)	6-1/4 (159)	1-1/2 (38)	3-1/2 (89)	16 (406)	14 (356)	6-1/4 (159)	2-7/8 (73)	3/8 (10)	3/16 (5)	11 (279)	-	-	28-1/2 (724)	16 (406)
5	6	11	4	10 (254)	12 (305)	11 (279)	4-1/4 (108)	7/8 (22)	3/4 (19)	19-3/4 (502)	5 (127)	5-1/2 (140)	1-1/2 (38)	3-1/2 (89)	16 (406)	11-1/4 (286)	5-1/2 (140)	2-7/8 (73)	3/8 (10)	3/16 (5)	11 (279)	-	3/4 (19)	28-1/2 (724)	13-1/4 (337)
5	6	15	4	10 (254)	12 (305)	12-1/2 (318)	4-1/4 (108)	7/8 (22)	3/4 (19)	22-1/2 (572)	5 (127)	6-1/4 (159)	1-1/2 (38)	3-1/2 (89)	16 (406)	13-1/4 (337)	6-1/4 (159)	2-7/8 (73)	3/8 (10)	3/16 (5)	11 (279)	-	-	28-1/2 (724)	15 (343)
5	6	17	4	10 (254)	12 (305)	12-1/2 (318)	4-1/4 (108)	7/8 (22)	3/4 (19)	22-1/2 (572)	5 (127)	6-1/4 (159)	1-1/2 (38)	3-1/2 (89)	16 (406)	14 (356)	6-1/4 (159)	2-7/8 (73)	3/8 (10)	3/16 (5)	11 (279)	-	-	28-1/2 (724)	15 (343)
6	8	11	4	10 (254)	12 (305)	12-1/2 (318)	4-1/4 (108)	7/8 (22)	3/4 (19)	21-7/8 (556)	5 (127)	6-1/4 (159)	1-1/2 (38)	3-1/2 (89)	16 (406)	11-3/4 (298)	6-1/4 (159)	2-7/8 (73)	3/8 (10)	3/16 (5)	11 (279)	-	3/2 (32)	28-1/2 (724)	14-1/2 (368)
6	8	11HH	4A	12 (305)	14-1/2 (360)	16-1/2 (419)	5 (127)	1-1/4 (32)	7/8 (22)	25-1/2 (648)	6 (152)	8-5/8 (159)	1-1/2 (38)	3-1/2 (89)	18-1/8 (461)	10 (254)	8-5/8 (219)	2 (51)	3/8 (10)	3/16 (5)	12-1/8 (308)	-	-	32-3/4 (832)	15 (381)
8	8	11	4	10 (254)	12 (305)	12-1/2 (318)	4-1/4 (108)	7/8 (22)	3/4 (19)	21-3/4 (552)	5 (127)	6-1/4 (159)	1-1/2 (38)	3-1/2 (89)	16 (406)	12 (305)	6-1/4 (159)	2-7/8 (73)	3/8 (10)	3/16 (5)	11 (279)	1-1/4 (32)	1-1/4 (32)	28-1/2 (724)	14-1/2 (368)

NOTES:

- All dimensions in inches (mm).
- Dimensions may vary ± 3/8" (10).
- Not for construction purposes unless certified.
- Discharge and suction flanges – ANSI Standard flat face.
- 1/4" NPT gauge tap on top of suction/discharge flanges.

STD. 125# FLANGES	OPT. 250# FLANGES
-------------------	-------------------

AURORA® MODEL 411 PUMPS

6" THRU 14" PUMPS

POWER SERIES NO. 5-5A-6B-7-7A

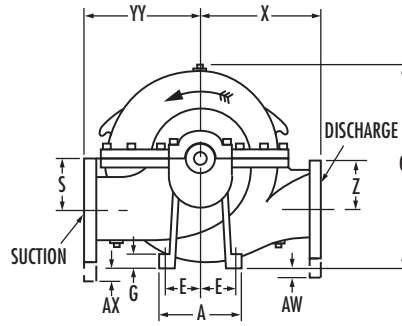
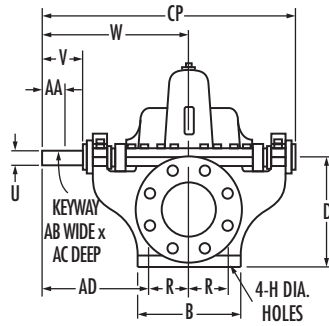

RIGHT-HAND ROTATION

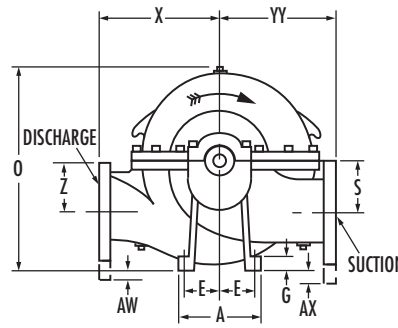
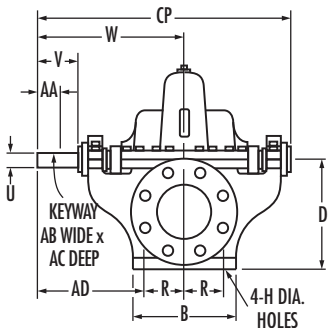

LEFT-HAND ROTATION

PUMP SIZE				POWER SERIES	A	B	D	E	G	H	O	R	S	U	V	W	X	Z	AA	AB	AC	AD	AW	AX	CP	YY
DISCH	SUCT	CASE BORE																								
6	8	14HH	5A	12 (305)	14-1/2 (368)	16-1/2 (351)	5 (127)	1-1/4 (32)	7/8 (22)	26-21/32 (609)	6 (152)	7-1/2 (191)	1-3/4 (44)	4-1/8 (105)	20-7/16 (381)	15 (191)	7-1/2 (73)	2-7/8 (10)	3/8 (3)	3/16 (5)	14-7/16 (367)	-	-	36-3/4 (933)	17 (432)	
6	8	15	5	12 (305)	14 (356)	13-1/2 (343)	5 (127)	1 (25)	7/8 (22)	24-7/8 (632)	6 (152)	6-3/4 (171)	1-3/4 (44)	4 (102)	18 (457)	14-1/4 (362)	6-3/4 (171)	2-7/8 (73)	3/8 (10)	3/16 (5)	12 (305)	-	3/4 (19)	32 (813)	16-3/4 (425)	
6	8	18	5	12 (305)	14 (356)	14-3/4 (375)	5 (127)	3/4 (19)	7/8 (22)	27-1/4 (692)	6 (152)	8 (203)	1-3/4 (44)	4 (102)	18 (457)	16 (406)	8 (203)	2-7/8 (73)	3/8 (10)	3/16 (5)	12 (305)	-	3/4 (19)	32 (813)	18 (457)	
6	8	20	5	12 (305)	14 (356)	14-3/4 (375)	5 (127)	1 (25)	7/8 (22)	27-3/4 (705)	6 (152)	8 (203)	1-3/4 (44)	4 (102)	18 (457)	15-3/4 (400)	8 (203)	2-7/8 (73)	3/8 (10)	3/16 (5)	12 (305)	-	3/4 (19)	32 (813)	18 (457)	
8	10	12	5	12 (305)	14 (356)	14-3/4 (375)	5 (127)	1-1/4 (32)	7/8 (22)	26-3/8 (670)	6 (152)	8 (203)	1-3/4 (44)	4 (102)	18 (457)	17 (432)	9 (229)	2-7/8 (73)	3/8 (10)	3/16 (5)	12 (305)	1-3/4 (44)	2 (51)	32 (813)	17-3/4 (451)	
8	10	15	5	12 (305)	14 (356)	14-3/4 (375)	5 (127)	1-1/4 (32)	7/8 (22)	26-5/8 (676)	6 (152)	8 (203)	1-3/4 (44)	4 (102)	18 (457)	17 (432)	9 (229)	2-7/8 (73)	3/8 (10)	3/16 (5)	12 (305)	1-3/4 (44)	2 (51)	32 (813)	17-3/4 (451)	
8	10	17	5	12 (305)	14 (356)	14-3/4 (375)	5 (127)	1-1/4 (32)	7/8 (22)	27-1/8 (689)	6 (152)	8 (203)	1-3/4 (44)	4 (102)	18 (457)	17 (432)	8 (203)	2-7/8 (73)	3/8 (10)	3/16 (5)	12 (305)	3/4 (19)	2 (51)	32 (813)	17-3/4 (451)	
8	10	21	6B	15 (508)	17 (432)	18-1/2 (470)	9 (229)	1 (25)	7/8 (22)	32-1/2 (826)	7-1/2 (191)	9-1/2 (241)	2-1/8 (54)	5-7/16 (138)	21-7/8 (556)	18 (457)	9-1/2 (241)	4-3/4 (121)	1/2 (13)	1/4 (6)	14-3/8 (365)	-	-	38 (965)	21 (533)	
10	12	12B	6B	15 (381)	22 (559)	23 (584)	6-1/2 (165)	1 (25)	7/8 (22)	35-1/2 (902)	10 (254)	12 (305)	2-1/8 (54)	5-7/16 (138)	21-7/8 (556)	16 (406)	12 (305)	4-3/4 (121)	1/2 (13)	1/4 (6)	11-7/8 (302)	-	-	38 (965)	19 (483)	
10	12	15B&C	6B	15 (381)	22 (559)	25 (635)	6-1/2 (165)	1 (25)	7/8 (22)	38-1/2 (978)	10 (254)	13-1/2 (343)	2-1/8 (54)	5-7/16 (138)	21-7/8 (556)	17 (432)	13-1/2 (343)	4-3/4 (121)	1/2 (13)	1/4 (6)	11-7/8 (302)	-	-	38 (965)	20 (508)	
10	12	18	6B	15 (381)	22 (559)	25 (635)	6-1/2 (165)	1 (25)	7/8 (22)	39-1/2 (1003)	10 (254)	13-1/2 (343)	2-1/8 (54)	5-7/16 (138)	21-7/8 (556)	18 (457)	13-1/2 (343)	4-3/4 (121)	1/2 (13)	1/4 (6)	11-7/8 (302)	-	-	38 (965)	22 (559)	
10	12	18D	7A	15 (381)	22 (559)	25 (635)	6-1/2 (165)	1-1/4 (32)	7/8 (22)	40-3/8 (1026)	10 (254)	12-1/4 (311)	2-1/8 (53)	5-3/4 (146)	24-5/16 (618)	20 (508)	12-1/4 (311)	4-3/4 (121)	1/2 (13)	1/4 (6)	14-5/16 (364)	-	-	42-15/16 (1090)	24 (610)	
8	12	24	7	15 (381)	22 (559)	26 (660)	6-1/2 (165)	1-1/8 (29)	7/8 (22)	43-7/8 (1114)	10 (254)	15 (381)	2-1/2 (64)	6-5/8 (168)	25-1/4 (641)	20 (508)	15 (381)	5 (127)	5/8 (16)	5/16 (8)	15-1/4 (387)	-	-	43-7/8 (1114)	25 (635)	
12	14	15B	7	15 (381)	22 (559)	24 (610)	6-1/2 (165)	1 (25)	7/8 (22)	39 (991)	10 (254)	15 (381)	2-1/2 (64)	6-5/8 (168)	25-1/4 (641)	17 (432)	15 (381)	5 (127)	5/8 (16)	5/16 (8)	15-1/4 (387)	1-1/4 (32)	2-1/2 (64)	43-7/8 (1114)	22 (559)	
12	14	18	7	15 (381)	22 (559)	24 (610)	6-1/2 (165)	1 (25)	7/8 (22)	40-1/8 (1019)	10 (254)	15 (381)	2-1/2 (64)	6-5/8 (168)	25-1/4 (641)	18 (457)	15 (381)	5 (127)	5/8 (16)	5/16 (8)	15-1/4 (387)	1-1/4 (32)	2-1/2 (64)	43-7/8 (1114)	23 (584)	
14	16	18	7	15 (381)	22 (559)	29-1/4 (743)	6-1/2 (165)	1 (25)	7/8 (22)	47-1/2 (1207)	10 (254)	16 (406)	2-1/2 (64)	6-5/8 (168)	25-1/4 (641)	22 (559)	16 (406)	5 (127)	5/8 (16)	5/16 (8)	15-1/4 (387)	-	-	43-7/8 (1114)	27 (686)	

NOTES:

- All dimensions in inches (mm).
- Dimensions may vary ± 3/8" (10).
- Not for construction purposes unless certified.
- Discharge and suction flanges – ANSI Standard flat face.
- 1/4" NPT gauge tap on top of suction/discharge flanges.

STD. 125# FLANGES	OPT. 250# FLANGES
-------------------	-------------------

AURORA® MODEL 411 PUMPS

10" AND 12" BOTTOM SUCTION PUMPS

POWER SERIES NO. 6B & 7

Section **410** Page **203**
Date **May 2013**

Supersedes Section 410 Page 203
Dated April 2013

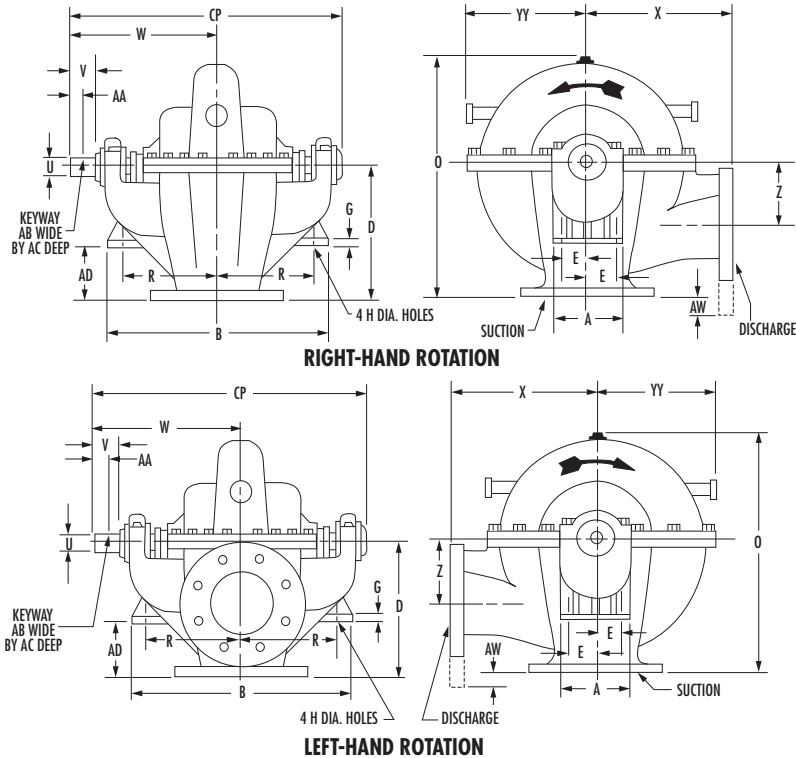

PUMP SIZE			POWER SERIES	A	B	D	E	G	H	O	R	U	V	W	X	Z	AA	AB	AC	AD	AW	CP	YY
DISCH	SUCT	CASE BORE																					
10	12	18	6B	16-3/4 (425)	26 (660)	25 (635)	7-1/2 (191)	1-1/4 (32)	7/8 (22)	39-1/2 (1003)	11-3/4 (298)	2-1/8 (54)	5-7/16 (138)	21-7/8 (556)	18 (457)	13-1/2 (343)	4-3/4 (121)	1/2 (13)	1/4 (6)	12-1/2 (318)	-	38 (965)	18 (457)
12	14	15B	7	21 (533)	32 (813)	25 (635)	9 (229)	1-1/4 (32)	7/8 (22)	40 (1016)	14-1/2 (368)	2-1/2 (64)	6-5/8 (168)	25-1/4 (641)	17 (432)	15 (381)	5 (127)	5/8 (16)	5/16 (8)	13-11/16 (348)	1/4 (6)	43-7/8 (1114)	19 (483)

NOTES:

1. All dimensions in inches (mm).
2. Dimensions may vary $\pm 3/8"$ (10).
3. Not for construction purposes unless certified.
4. Discharge and suction flanges – ANSI Standard flat face.
5. 1/4" NPT gauge tap on top of suction/discharge flanges.

STD. 125# FLANGES	OPT. 250# FLANGES
-------------------	-------------------

AURORA® MODEL 411 PUMPS

ON STEEL BASE

2" THRU 4" PUMPS

POWER SERIES NO. 1-2-3

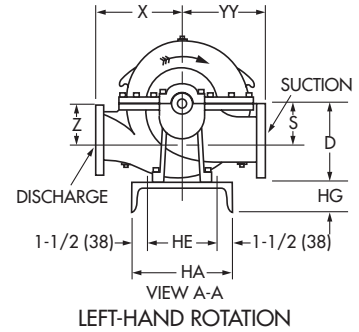
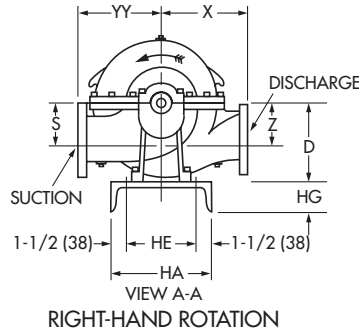
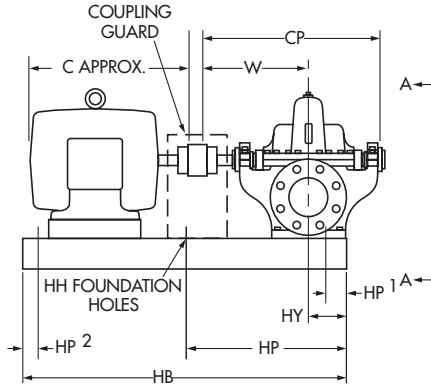

BASE	SIZE	HA	HB	HE	HG	HH		HP	HP1	HP2
						QTY	SIZE			
2	10 x 28	10 (254)	28 (711)	7 (178)	2-5/8 (67)	2	5/8 (16)	14 (356)	-	-
3	12 x 30	12 (305)	30 (762)	9 (229)	3 (76)	2	5/8 (16)	15 (381)	-	-
4	12 x 34	12 (305)	34 (864)	9 (229)	3 (76)	4	5/8 (16)	20 (508)	-	1 (25)
5	12 x 38	12 (305)	38 (965)	9 (229)	3 (76)	4	5/8 (16)	20 (508)	-	1 (25)
6	13 x 38	13 (330)	38 (965)	10 (254)	4 (102)	4	3/4 (19)	-	1 (25)	1 (25)
7	13 x 42	13 (330)	42 (1067)	10 (254)	4 (102)	4	3/4 (19)	24 (610)	-	1 (25)
8	15 x 40	15 (381)	40 (1016)	12 (305)	3-3/8 (86)	4	3/4 (19)	-	1 (25)	1 (25)
9	15 x 44	15 (381)	44 (1118)	12 (305)	3-3/8 (86)	4	3/4 (19)	24 (610)	-	1 (25)
10	18 x 44	18 (457)	44 (1118)	15 (381)	4 (102)	4	3/4 (19)	-	1 (25)	1 (25)
11	18 x 48	18 (457)	48 (1219)	15 (381)	4 (102)	4	3/4 (19)	-	1 (25)	1 (25)
12	18 x 54	18 (457)	54 (1372)	15 (381)	4 (102)	4	3/4 (19)	-	1 (25)	1 (25)
15	22 x 60	22 (559)	60 (1524)	19 (483)	4 (102)	4	3/4 (19)	-	1 (25)	1 (25)

NOTE: WHEN 2 "D" DIMENSIONS ARE INDICATED ALWAYS USE THE LARGER FIGURE.

PUMP SIZE			POWER SERIES	D	S	W	X	Z	CP	HY	YY
DISCH	SUCT	CASE BORE									
2	2-1/2	9	1	7 (178)	3-1/2 (89)	11-5/8 (295)	8-1/2 (216)	3-1/2 (89)	20-1/2 (521)	4 (102)	9 (229)
2	2-1/2	10		7 (178)	3-1/2 (89)		8-1/2 (216)	3-1/2 (89)			9 (229)
2	2-1/2	12		8 (203)	4 (102)		10 (254)	4 (102)			10-3/4 (273)
2-1/2	3	10B	2	8 (203)	4 (102)	13-1/2 (343)	9-3/4 (248)	4 (102)	24 (610)	5 (127)	10 (254)
2-1/2	3	12		9** (229)**	4-1/2 (114)		11 (279)	4-1/2 (114)			11-1/2 (292)
3	4	10B & C		9** (229)**	4-1/2 (114)		10 (254)	4-1/2 (114)			11 (279)
3	4	14	3	10 (254)	5 (127)	14-1/2 (368)	12 (305)	5 (127)	26 (660)	6 (152)	13 (330)
4	5	10B		9** (229)**	4-5/8 (118)		10 (254)	4-1/2 (114)			11-1/4 (286)
4	5	11A & C		10± (254±)	5 (127)		11-1/4 (286)	5 (127)			12-3/4 (324)
4	5	11D	10± (254±)	5 (127)	12 (286)	5 (127)	12-3/4 (324)				
4	5	15	11 (279)	5-1/2 (140)	13 (330)	5-1/2 (140)	14 (356)				

PUMP SIZE	FRAME	143T	145T	182T	184T	213T	215T	254T	256T	284TS	284T	286TS	286T	324TS	324T	326TS	326T	364TS	364T	365TS	365T	404TS	405TS	444TS
	C	13 (330)	13 (330)	13 (330)	14 (356)	16 (406)	18 (457)	21 (533)	23 (584)	22 (559)	24 (610)	24 (610)	25 (635)	25 (635)	26 (660)	26 (660)	28 (711)	27 (686)	29 (737)	28 (711)	30 (762)	30 (762)	31 (787)	34 (864)
	D	-	-	-	-	-	-	-	-	-	-	-	-	8 (203)	8 (203)	8 (203)	9 (229)	9 (229)	9 (229)	9 (229)	9 (229)	10 (254)	10 (254)	11 (279)
2 x 2-1/2 x 9	BASE	2		3		4		6		8		9		10										
2 x 2-1/2 x 10	BASE	2		3		4		6		8		9		10										
2 x 2-1/2 x 12	BASE	2		3		4		6		8		9		10										
2-1/2 x 3 x 10B	BASE	2		3		4		6		8		9		10										
2-1/2 x 3 x 12	BASE	2		3		4		6		8		9		10										
3 x 4 x 10B & C	BASE	3		4		5		7		9		11		12										
3 x 4 x 14	BASE	3		4		5		7		9		11		12										
4 x 5 x 10B	BASE	3		4		5		7		9		11		12										
4 x 5 x 11A & C	BASE	3		4		5		7		9		11		12										
4x5x11D	BASE	-		5		7		9		11		12		15										
4 x 5 x 15	BASE	-		5		7		9		11		12		15										

NOTES:

- All dimensions in inches (mm).
- Dimensions may vary ± 3/8" (10).
- Not for construction purposes unless certified.
- Coupling gap may vary 1/8" (3) to 2-1/16" (52).

5. Conduit box is shown in approximate location. Dimensions are not specified as they vary with each motor manufacturer.

6. Discharge and suction flanges – ANSI Standard flat face.

7. 1/4" NPT gauge tap on top of suction/discharge flanges.

** Dimension "D" is 10-1/2" (267) when using frames 324TS thru 365T.

± Dimension "D" is 10-1/2" (267) when using frames 404TS thru 405TS.

‡ Dimension "D" is 11" (279) when using frames 444TS.

STD. 125# FLANGES	OPT. 250# FLANGES
-------------------	-------------------

AURORA® MODEL 411 PUMPS

ON STEEL BASE

4" THRU 8" PUMPS

POWER SERIES NO. 4-4A-5-5A

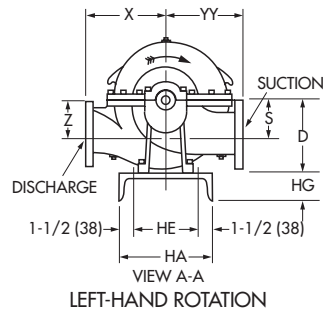
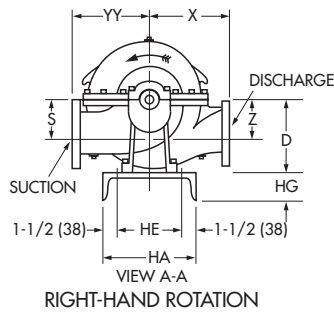
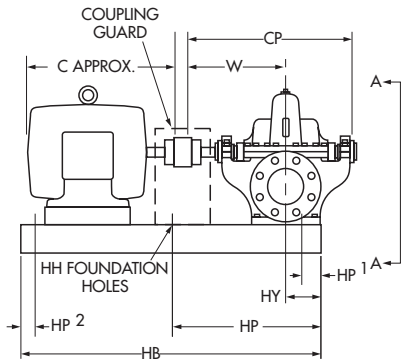

BASE	SIZE	HA	HB	HE	HG	HH						
						QTY	SIZE	HP	HP1	HP2		
5	12 x 38	12 (305)	38 (965)	9 (229)	3 (76)	4	3/4 (19)	1 (25)	5/8 (16)	20 (508)	-	
7	13 x 42	13 (330)	42 (1067)	10 (254)	4 (102)				24 (610)	-		
9	15 x 44	15 (381)	44 (1118)	12 (305)	3-3/8 (86)				24 (610)	-		
10	18 x 44	18 (457)	44 (1219)	15 (381)	4 (102)				-	-		
11	18 x 48	18 (457)	48 (1219)	15 (381)	4 (102)				-	1 (25)		
12	18 x 54	18 (457)	54 (1372)	15 (381)	4 (102)				-	-		
13	18 x 60	18 (457)	60 (1524)	15 (381)	4 (102)				24 (610)	-		
14	18 x 65	18 (457)	65 (1651)	15 (381)	4 (102)				24 (610)	-		
15	22 x 60	22 (559)	60 (1524)	19 (483)	4 (102)				-	-		
16	22 x 72	22 (559)	72 (1829)	19 (483)	4 (102)				-	1 (25)		
17	22 x 84	22 (559)	84 (2134)	19 (483)	4 (102)				-	-		

PUMP SIZE			POWER SERIES	S	W	X	Z	CP	HY	YY		
DISCH	SUCT	CASE BORE										
4	6	18B	4	12-1/2 (318)	6-1/4 (159)	14 (356)	6-1/4 (159)			16 (406)		
5	6	11A & C		11** (279)**	5-1/2 (140)		11-1/4 (286)	5-1/2 (140)			13-1/4 (337)	
5	6	15		12-1/2 (318)	6-1/4 (159)	16 (406)	13-1/4 (337)	6-1/4 (159)	28-1/2 (724)	6 (152)	15 (381)	
5	6	17		12-1/2 (318)	6-1/4 (159)		14 (356)	6-1/4 (159)			15 (381)	
6	8	11		12-1/2 (318)	6-1/4 (159)		11-3/4 (286)	6-1/4 (159)			14-1/2 (368)	
8	8	11B		12-1/2± (318±)	6-1/4 (159)		12 (305)	6-1/4 (159)			14-1/2 (368)	
6	8	11HH		4A	16-1/2 (419)	8-5/8 (219)	18-1/8 (461)	10 (254)	8-5/8 (219)	32-3/4 (832)	7 (178)	17 (432)
6	8	14HH		5A	16-1/2 (419)	7-1/2 (191)	20-7/16 (519)	15 (381)	7-1/2 (191)	36-3/4 (933)	7 (178)	17 (432)
6	8	15		5	13-1/2 (343)	6-3/4 (171)		14-1/4 (362)	6-3/4 (171)		16-3/4 (425)	
6	8	16A, B & C			14-3/4 (375)	8 (203)		16 (406)	8 (203)			18 (457)
6	8	20			14-3/4 (375)	8 (203)	18 (457)	15-3/4 (400)	8 (203)			18 (457)
8	10	12 & 12A			14-3/4 (375)	8 (203)		17 (432)	9 (229)	32 (813)	7 (178)	17-3/4 (451)
8	10	15A & B			14-3/4 (375)	8 (203)		17 (432)	9 (229)			17-3/4 (451)
8	10	17B			14-3/4 (375)	8 (203)		17 (432)	8 (203)			17-3/4 (451)

FRAME		213T	215T	254T	256T	284TS	284T	286TS	286T	324TS	324T	326TS	326T	364TS	364T	365TS	365T	404TS	404T	405TS	405T	444TS	444T	445TS	445T	447TS	447T	449TS	449T
PUMP SIZE	C	16 (406)	18 (457)	21 (533)	23 (584)	22 (559)	24 (610)	24 (610)	25 (635)	25 (635)	26 (660)	26 (660)	28 (711)	27 (686)	29 (737)	28 (711)	30 (762)	30 (762)	33 (838)	31 (787)	35 (889)	34 (864)	38 (965)	36 (1016)	40 (914)	40 (914)	44 (1118)	45 (1143)	49 (1245)
4 x 6 x 18B	BASE																												
5 x 6 x 11A & C	BASE																												
5 x 6 x 15	BASE																												
5 x 6 x 17	BASE																												
6 x 8 x 11	BASE																												
8 x 8 x 11B	BASE																												
6 x 8 x 11HH	BASE																												
6 x 8 x 14HH	BASE																												
6 x 8 x 15	BASE																												
6 x 8 x 16A, B, & C	BASE																												
6 x 8 x 20	BASE																												
8 x 10 x 12 & 12A	BASE																												
8 x 10 x 15A & B	BASE																												
8 x 10 x 17B	BASE																												

NOTES:

- All dimensions in inches (mm).
- Dimensions may vary ± 3/8" (10).
- Not for construction purposes unless certified.
- Coupling gap may vary 1/8" (3) to 2-1/16" (52).
- Conduit box is shown in approximate location. Dimensions are not specified as they vary with each motor manufacturer.
- Discharge and suction flanges - ANSI Standard flat face.
- 1/4" NPT gauge tap on top of suction/discharge flanges.

- ** Dimension "D" is 12" (305) when using frames 404TS thru 449T.
- ‡ Dimension "D" is 14-1/2" (368) when using frames 404TS thru 449T.

STD. 125# FLANGES	OPT. 250# FLANGES
-------------------	-------------------

AURORA® MODEL 411 PUMPS

ON STEEL BASE

8" THRU 12" PUMPS

POWER SERIES NO. 6B-7A-7

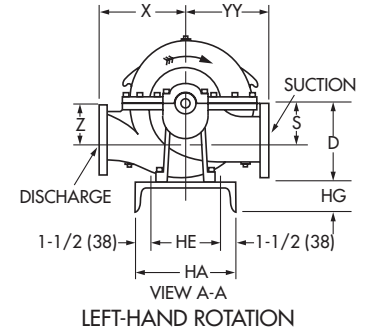
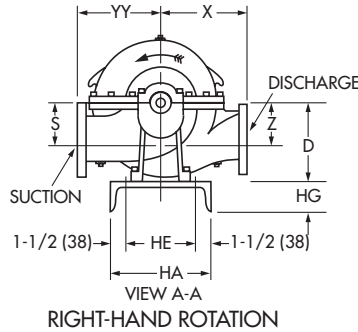
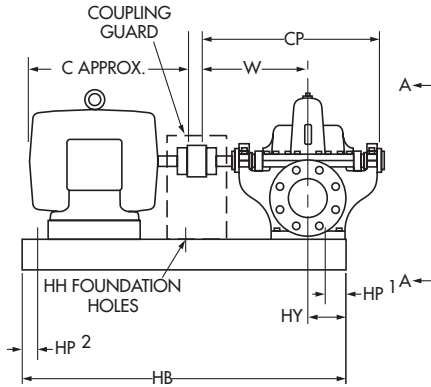

BASE	SIZE	HA	HB	HE	HG	HH		HP1	HP2
						QTY	SIZE		
13	18 x 60	18	60	15	4	4	3/4	24	1
		(457)	(1524)	(381)	(102)	(19)	(610)	(25)	
14	18 x 65	18	65	15	4	4	3/4	24	1
		(457)	(1651)	(381)	(102)	(19)	(610)	(25)	
15	22 x 60	22	60	19	4	4	3/4	1	1
		(559)	(1524)	(483)	(102)	(19)	(25)	(25)	
16	22 x 72	22	72	19	4	4	3/4	1	1
		(559)	(1829)	(483)	(102)	(19)	(25)	(25)	
17	22 x 84	22	84	19	4	4	3/4	1	1
		(559)	(2134)	(483)	(102)	(19)	(25)	(25)	
18	22 x 84	22	84	19	4	4	3/4	1	1
		(559)	(2134)	(483)	(102)	(19)	(25)	(25)	

PUMP SIZE			POWER SERIES	D	S	W	X	Z	CP	HY	YY		
DISCH	SUCT	CASE BORE											
8	10	21 & 21A	6B	18-1/2 (470)	9-1/2 (241)	21-7/8 (556)	18 (457)	9-1/2 (241)	38 (965)	11 (279)	21 (533)		
		12B		23 (584)	12 (305)	21-7/8 (556)	16 (406)	12 (305)	38 (965)	11 (279)	19 (483)		
10	12	15B & C		25 (635)	13-1/2 (343)	21-7/8 (708)	17 (432)	13-1/2 (343)	38 (965)	11 (279)	20 (508)		
		18		25 (635)	13-1/2 (343)	21-7/8 (708)	18 (457)	13-1/2 (343)	38 (965)	11 (279)	22 (559)		
10	12	18D		7A	25 (635)	12-1/4 (311)	24-5/16 (566)	20 (508)	12-1/4 (311)	42-15/16 (1091)	11 (279)	24 (610)	
		24			26 (660)	15 (381)	25-1/4 (641)	20 (508)	15 (381)	43-7/8 (1114)	11 (279)	25 (635)	
12	14	15B			7	24 (610)	15 (381)	25-1/4 (641)	17 (432)	15 (381)	43-7/8 (1114)	11 (279)	22 (559)
		18A				24 (610)	15 (381)	25-1/4 (641)	18 (457)	15 (381)	43-7/8 (1114)	11 (279)	23 (584)
14	16	18				29-1/4 (743)	16 (406)	25-1/4 (641)	22 (559)	16 (406)	43-7/8 (1114)	11 (279)	27 (686)

PUMP SIZE	FRAME	286TS	286T	324TS	324T	326TS	326T	364TS	364T	365TS	365T	404TS	404T	405TS	405T	444TS	444T	445TS	445T	447TS	447T	449TS	449T
	C	24 (610)	25 (635)	25 (635)	26 (660)	26 (660)	28 (711)	27 (686)	29 (737)	28 (711)	30 (762)	30 (762)	33 (838)	31 (787)	35 (889)	34 (864)	38 (965)	36 (1016)	40 (914)	40 (914)	44 (1118)	45 (1143)	49 (1245)
8 x 10 x 21 & 21A	BASE	13				14				16				17									
10 x 12 x 12B	BASE	13				14				16				17									
10 x 12 x 15B & C	BASE	13				14				16				17									
10 x 12 x 18	BASE	13				14				16				17									
10 x 12 x 18D	BASE	13				14				16				17									
8 x 12 x 24	BASE	13				14				16				17									
12 x 14 x 15B	BASE	13				14				16				17									
12 x 14 x 18A	BASE	13				14				16				17									
14 x 16 x 18	BASE	13				14				16				17									

NOTES:

- All dimensions in inches (mm).
- Dimensions may vary ± 3/8" (10).
- Not for construction purposes unless certified.
- Coupling gap may vary 1/8" (3) to 2-1/16" (52).
- Conduit box is shown in approximate location. Dimensions are not specified as they vary with each motor manufacturer.
- Discharge and suction flanges - ANSI Standard flat face.
- 1/4" NPT gauge tap on top of suction/discharge flanges.

STD. 125# FLANGES	OPT. 250# FLANGES
-------------------	-------------------

THIS PAGE INTENTIONALLY LEFT BLANK

AURORA® MODEL 411 PUMPS

ON STEEL DRIP RIM BASE

2"-2-1/2"-3"-4" PUMPS

POWER SERIES NO. 1-2-3

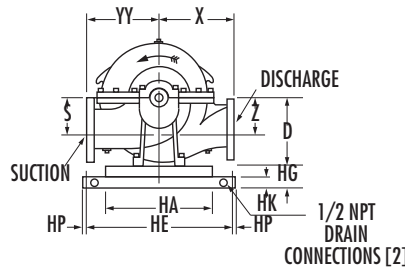
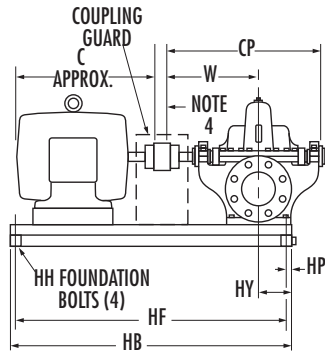

RIGHT-HAND ROTATION

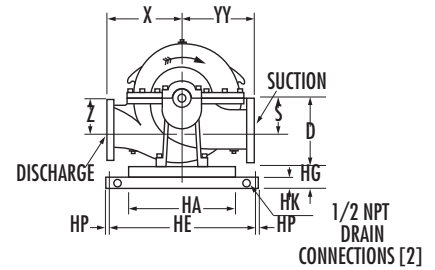

LEFT-HAND ROTATION

BASE	SIZE	HA	HB	HE	HF	HG	HH	HK	HP
3	9 x 33	9 (229)	33-1/2 (851)	13-3/4 (349)	32-1/4 (819)	3 (76)	3/4 (19)	1-1/2 (38)	5/8 (16)
5	11 x 36	11 (279)	36-1/2 (927)	15-7/8 (403)	35-1/8 (892)	3 (76)	7/8 (22)	1-1/2 (38)	11/16 (18)
6	11 x 42	11 (279)	42-1/2 (1080)	15-7/8 (403)	41-1/8 (1045)	3 (76)	7/8 (22)	1-1/2 (38)	11/16 (18)
8	14 x 42	14 (356)	42-1/2 (1080)	19 (483)	41 (1041)	3 (76)	1 (25)	1-1/2 (38)	3/4 (19)
9	14 x 48	14 (356)	48-1/2 (1232)	19 (483)	47 (1194)	3 (76)	1 (25)	1-1/2 (38)	3/4 (19)
11	18 x 46	18 (457)	46-1/2 (1181)	25-1/8 (638)	44-7/8 (1140)	4 (102)	1-1/8 (29)	2 (51)	13/16 (21)
12	18 x 54	18 (457)	54-1/2 (1384)	25-1/8 (638)	52-7/8 (1343)	4 (102)	1-1/8 (29)	2 (51)	13/16 (21)
15	22 x 54	22 (559)	54-1/2 (1384)	29-1/8 (740)	52-7/8 (1343)	4-1/2 (114)	1-1/8 (29)	2 (51)	13/16 (21)

NOTE: WHEN 2 "D" DIMENSIONS ARE INDICATED ALWAYS USE THE LARGER FIGURE.

PUMP SIZE		CASE BORE	POWER SERIES	D	S	W	X	Z	CP	HY	YY
DISCH	SUCT										
2	2-1/2	9	1	7 (178)	3-1/2 (89)		8-1/2 (216)	3-1/2 (89)			9 (229)
2	2-1/2	10		7 (178)	3-1/2 (89)	11-5/8 (295)	8-1/2 (216)	3-1/2 (89)	20-1/2 (521)	4-1/2 (114)	9 (229)
2	2-1/2	12		8 (203)	4 (102)		10 (254)	4 (102)			10-3/4 (273)
2-1/2	3	10B	2	8 (203)	4 (102)		9-3/4 (248)	4 (102)			10 (254)
2-1/2	3	12		9** (229)**	4-1/2 (114)		11 (279)	4-1/2 (114)			11-1/2 (292)
3	4	10B & C		9** (229)**	4-1/2 (114)	13-1/2 (343)	10 (254)	4-1/2 (114)	24 (610)	5-1/2 (140)	11 (279)
3	4	14	3	10 (254)	5 (127)		12 (305)	5 (127)			13 (330)
4	5	10B		9** (229)**	4-5/8 (118)		10 (254)	4-1/2 (114)			11-1/4 (286)
4	5	11A & C		10‡ (254‡)	5 (127)		11-1/4 (286)	5 (127)			12-3/4 (324)
4	5	11D	3	10‡ (254‡)	5 (127)	14-1/2 (368)	12 (305)	5 (127)		26 (660)	12-3/4 (324)
4	5	15		11 (279)	5-1/2 (140)		13 (330)	5-1/2 (140)			14 (356)

PUMP SIZE			FRAME	143T	145T	182T	184T	213T	215T	254T	256T	284TS	284T	286TS	286T	324TS	324T	326TS	326T	364TS	364T	365TS	365T	404TS	405TS	444TS		
DISCH	SUCT	CASE BORE		D	13 (330)	13 (330)	13 (330)	14 (356)	16 (406)	18 (457)	21 (533)	23 (584)	22 (559)	24 (610)	24 (610)	25 (635)	25 (635)	26 (660)	26 (660)	28 (711)	27 (686)	29 (737)	28 (711)	30 (762)	30 (762)	31 (787)	34 (864)	
2	2-1/2	9	BASE													8 (203)	8 (203)	8 (203)	8 (203)	9 (229)	9 (229)	9 (229)	9 (229)					
2	2-1/2	10	1	BASE		3			5				8			11												
2	2-1/2	12	BASE																									
2-1/2	3	10B	2	BASE																								
2-1/2	3	12		BASE																								
3	4	10B & C		BASE		3				5		8		9			11	12	11			12						
3	4	14	BASE																									
4	5	10B	BASE																									
4	5	11A & C	BASE																									
4	5	11D	3	BASE					5	6	8		9		11													
4	5	15		BASE																		12				15		

NOTES:

- All dimensions in inches (mm).
- Dimensions may vary ± 3/8" (10).
- Not for construction purposes unless certified.
- Coupling gap may vary 1/8" (3) to 2-1/16" (52).
- Conduit box is shown in approximate location. Dimensions are not specified as they vary with each motor manufacturer.

- Discharge and suction flanges – ANSI Standard flat face.
- 1/4" NPT gauge tap on top of suction/discharge flanges.
- ** Dimension "D" is 10-1/2" (267) when using frames 324TS thru 365T.
- ‡ Dimension "D" is 10-1/2" (267) when using frames 404TS thru 405TS.

STD. 125# FLANGES	OPT. 250# FLANGES
-------------------	-------------------

Supersedes Section 410 Page 302
Dated May 2013

AURORA® MODEL 411 PUMPS

ON STEEL DRIP RIM BASE

4"-5"-6"-8" PUMPS

POWER SERIES NO. 4-4A-5-5A

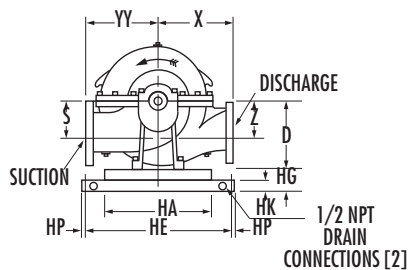
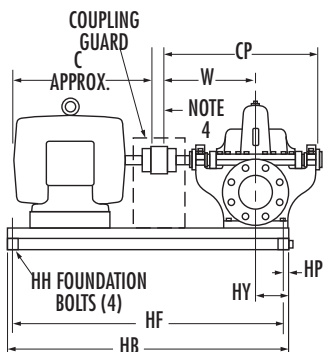

RIGHT-HAND ROTATION

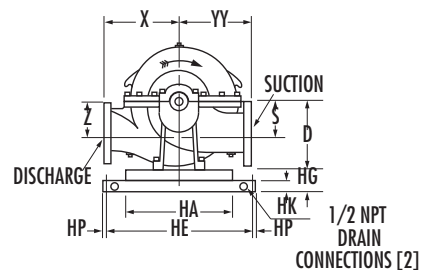

LEFT-HAND ROTATION

BASE	SIZE	HA	HB	HE	HF	HG	HH	HK	HP
6	11 x 42	11 (279)	42-1/2 (1080)	15-7/8 (403)	41-1/8 (1045)	3 (76)	7/8 (22)	1-1/2 (38)	11/16 (18)
9	14 x 48	14 (356)	48-1/2 (1232)	19 (483)	47 (1194)	3 (76)	1 (25)	1-1/2 (38)	3/4 (19)
11	18 x 46	18 (457)	46-1/2 (1181)	25-1/8 (638)	44-7/8 (1140)	4 (102)	1-1/8 (29)	2 (51)	13/16 (21)
12	18 x 54	18 (457)	54-1/2 (1384)	25-1/8 (638)	52-7/8 (1343)	4 (102)	1-1/8 (29)	2 (51)	13/16 (21)
13	18 x 64	18 (457)	64-1/2 (1638)	25-1/8 (638)	62-7/8 (1597)	4 (102)	1-1/8 (29)	2 (51)	13/16 (21)
15	22 x 54	22 (559)	54-1/2 (1384)	29-1/8 (740)	52-7/8 (1343)	4-1/2 (114)	1-1/8 (29)	2 (51)	13/16 (21)
16	22 x 64	22 (559)	64-1/2 (1638)	29-1/8 (740)	62-7/8 (1597)	4-1/2 (114)	1-1/8 (29)	2 (51)	13/16 (21)
17	22 x 74	22 (559)	74-1/2 (1892)	29-1/8 (740)	72-7/8 (1851)	4-1/2 (114)	1-1/8 (29)	2 (51)	13/16 (21)
18	22 x 82	22 (559)	82-1/2 (2096)	29-1/8 (740)	80-7/8 (2054)	4-1/2 (114)	1-1/8 (29)	2 (51)	13/16 (21)

PUMP SIZE			POWER SERIES	D	S	W	X	Z	CP	HY	YY				
DISCH	SUCT	CASE BORE													
4	6	18B	4	12-1/2 (318)	6-1/4 (159)	16 (408)	14 (356)	6-1/4 (159)	28-1/2 (734)	6-1/2 (165)	16 (406)				
5	6	11A & C		11** (279**)	5-1/2 (140)		11-1/4 (286)	5-1/2 (140)			15 (381)				
5	6	15		12-1/2 (318)	6-1/4 (159)		13-1/4 (337)	6-1/4 (159)			15 (381)				
5	6	17		12-1/2 (318)	6-1/4 (159)		14 (356)	6-1/4 (159)			15 (381)				
6	8	11		12-1/2 (318)	6-1/4 (159)		11-3/4 (298)	6-1/4 (159)			14-1/2 (368)				
8	8	11B		12-1/2† (318†)	6-1/4 (159)		12 (305)	6-1/4 (159)			14-1/2 (368)				
6	8	11HH		4A	16-1/2 (419)		8-5/8 (219)	18-1/8 (461)			10 (254)	8-5/8 (219)	32-3/4 (832)	7 (178)	17 (432)
6	8	14HH		5A	16-1/2 (419)		7-1/2 (191)	20-7/16 (519)			15 (381)	7-1/2 (191)	36-3/4 (933)	7 (178)	17 (432)
6	8	15		5	13-1/2 (343)		6-3/4 (171)	18 (457)			14-1/4 (362)	6-3/4 (171)	32 (813)	7-1/2 (191)	16-3/4 (425)
6	8	18A, B & C			14-3/4 (375)		8 (203)				16 (406)	8 (203)			18 (457)
6	8	20			14-3/4 (375)		8 (203)				15-3/4 (400)	8 (203)			18 (457)
8	10	12 & 12A			14-3/4 (375)		8 (203)				17 (432)	9 (229)			17-3/4 (451)
8	10	15A & B	14-3/4 (375)		8 (203)	17 (432)	9 (229)		17-3/4 (451)						
8	10	17B	14-3/4 (375)		8 (203)	17 (432)	8 (203)		17-3/4 (451)						

PUMP SIZE		FRAME	213T	215T	254T	256T	284TS	284T	286TS	286T	324TS	324T	326TS	326T	364TS	364T	365TS	365T	404TS	404T	405TS	405T	444TS	444T	445TS	445T	447TS	447T	449TS	449T	
DISCH	SUCT	CASE BORE	16 (406)	18 (457)	21 (533)	23 (584)	22 (559)	24 (610)	24 (610)	25 (635)	25 (635)	26 (660)	26 (660)	28 (711)	27 (686)	29 (737)	28 (711)	30 (762)	30 (762)	33 (838)	31 (787)	35 (889)	34 (864)	38 (965)	36 (914)	40 (1016)	40 (1016)	44 (1118)	45 (1143)	49 (1245)	
4	6	18B	BASE																												
5	6	11A & C	BASE																												
5	6	15	BASE	6	9			11						12						15			16					17			
5	6	17	BASE																												
6	8	11	BASE																												
8	8	11B	BASE																												
6	8	11HH	BASE										15										16								
6	8	14HH	BASE										16										16	16			17		17	18	
6	8	15	BASE																												
6	8	18A, B & C	BASE																												
6	8	20	BASE																												
8	10	12 & 12A	BASE			9																									
8	10	15A & B	BASE																												
8	10	17B	BASE																												

- NOTES:
- All dimensions in inches (mm).
 - Dimensions may vary ± 3/8" (10).
 - Not for construction purposes unless certified.
 - Coupling gap may vary 1/8" (3) to 2-1/16" (52).
 - Conduit box is shown in approximate location. Dimensions are not specified as they vary with each motor manufacturer.

- Discharge and suction flanges – ANSI Standard flat face.
- 1/4" NPT gauge tap on top of suction/discharge flanges.
- ** Dimension "D" is 12" (305) when using frames 405TS-449T.
- † Dimension "D" is 14-1/2" (368) when using frames 404TS thru 449T.

STD. 125# FLANGES	OPT. 250# FLANGES
-------------------	-------------------

AURORA® MODEL 411 PUMPS

ON STEEL DRIP RIM BASE

8"-10"-12"-14" PUMPS

POWER SERIES NO. 6B-7-7A

Supersedes Section 410 Page 303
Dated May 2013

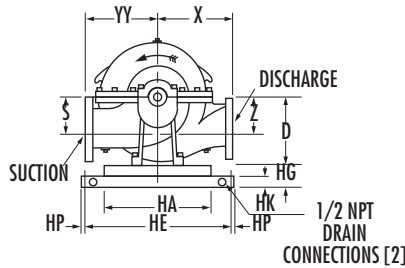
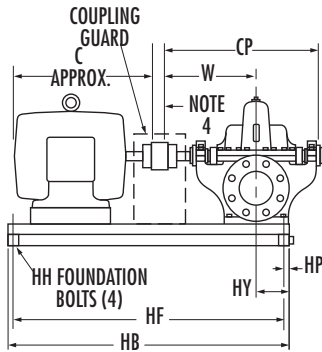

RIGHT-HAND ROTATION

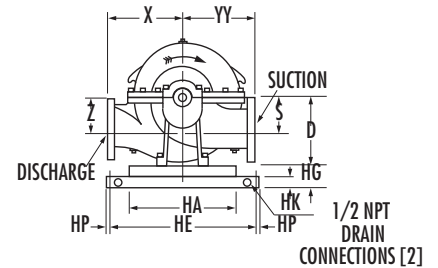

LEFT-HAND ROTATION

BASE	SIZE	HA	HB	HE	HF	HG	HH	HK	HP
13	18 x 64	18 (457)	64-1/2 (1638)	25-1/8 (638)	62-7/8 (1597)	4 (102)	1-1/8 (29)	2 (51)	13/16 (21)
17	22 x 74	22 (559)	74-1/2 (1892)	29-1/8 (740)	72-7/8 (1851)	4-1/2 (114)	1-1/8 (29)	2 (51)	13/16 (21)
18	22 x 82	22 (559)	82-1/2 (2096)	29-1/8 (740)	80-7/8 (2054)	4-1/2 (114)	1-1/8 (29)	2 (51)	13/16 (21)

PUMP SIZE			POWER SERIES	D	S	W	X	Z	CP	HY	YY
DISCH	SUCT	CASE BORE									
8	10	21 & 21A	6B	18-1/2 (467)	9-1/2 (241)	21-7/8 (556)	18 (457)	9-1/2 (241)	38 (965)	11-1/2 (292)	21 (533)
10	12	12B		23 (584)	12 (305)		16 (406)	12 (305)			19 (483)
10	12	15B & C		25 (635)	13-1/2 (343)		17 (432)	13-1/2 (343)			20 (508)
10	12	18		25 (635)	13-1/2 (343)		18 (457)	13-1/2 (343)			22 (559)
10	12	18D	7A	25 (635)	12-1/4 (311)	24-5/16 (556)	20 (508)	12-1/4 (311)	42-15/16 (1091)	11 (279)	24 (610)
8	12	24	7	26 (660)	15 (381)	25-1/4 (641)	20 (508)	15 (381)	43-7/8 (1114)	11-1/2 (292)	25 (635)
12	14	15B		24 (610)	15 (381)		17 (432)	15 (381)			22 (559)
12	14	18A		24 (610)	15 (381)		18 (457)	15 (381)			23 (584)
14	16	18		29-1/4 (743)	16 (406)		22 (559)	16 (406)			27 (686)

PUMP SIZE		FRAME	286TS	286T	324TS	324T	326TS	326T	364TS	364T	365TS	365T	404TS	404T	405TS	405T	444TS	444T	445TS	445T	447TS	447T	449TS	449T
DISCH	SUCT	CASE BORE	C	24 (610)	25 (635)	25 (635)	26 (660)	26 (660)	28 (711)	27 (686)	28 (711)	30 (762)	30 (762)	33 (838)	31 (787)	35 (889)	34 (864)	38 (965)	36 (914)	40 (1016)	40 (1016)	44 (1118)	45 (1143)	49 (1245)
8	10	21 & 21A	BASE																					
10	12	12B	BASE																					
10	12	15B & C	BASE	13													17							
10	12	18	BASE														18							
10	12	18D	BASE																					
8	12	24	BASE														18							
12	14	15B	BASE																					
12	14	18A	BASE														17							
14	16	18	BASE														18							

NOTES:

- All dimensions in inches (mm).
- Dimensions may vary $\pm 3/8"$ (10).
- Not for construction purposes unless certified.
- Coupling gap may vary 1/8" (3) to 2-1/16" (52).
- Conduit box is shown in approximate location. Dimensions are not specified as they vary with each motor manufacturer.
- Discharge and suction flanges – ANSI Standard flat face.
- 1/4" NPT gauge tap on top of suction/discharge flanges.

STD. 125# FLANGES	OPT. 250# FLANGES
-------------------	-------------------

THIS PAGE INTENTIONALLY LEFT BLANK