

MIXER SHAFT ASSEMBLY

1. ATTACH THE SHAFT COLLAR (ITEM 5) TO THE MIXER SHAFT (ITEM 4).

2. PLACE THE KEY (ITEM 7) ON THE MIXER SHAFT AND SLIDE THE MIXER SHAFT INTO THE HOLLOW OUTPUT SHAFT ON THE GEARDRIVE (ITEM 1).

3. PLACE THE THRUST WASHER (ITEM 6) OVER THE HOLLOW OUTPUT SHAFT ON THE TOP OF THE GEARDRIVE. APPLY THREADLOCKER TO THE THREADS OF THE HEX HEAD CAP SCREW (ITEM 3), INSTALL IT THRU THE THRUST WASHER AND INTO THE MIXER SHAFT. TORQUE THE GRADE 5 HEX HEAD CAP SCREW TO THE RECOMMENDED VALUE IN THE O&M MANUAL.

4. ATTACH THE GUARD (ITEM 2) ON THE TOP OF THE GEARDRIVE.

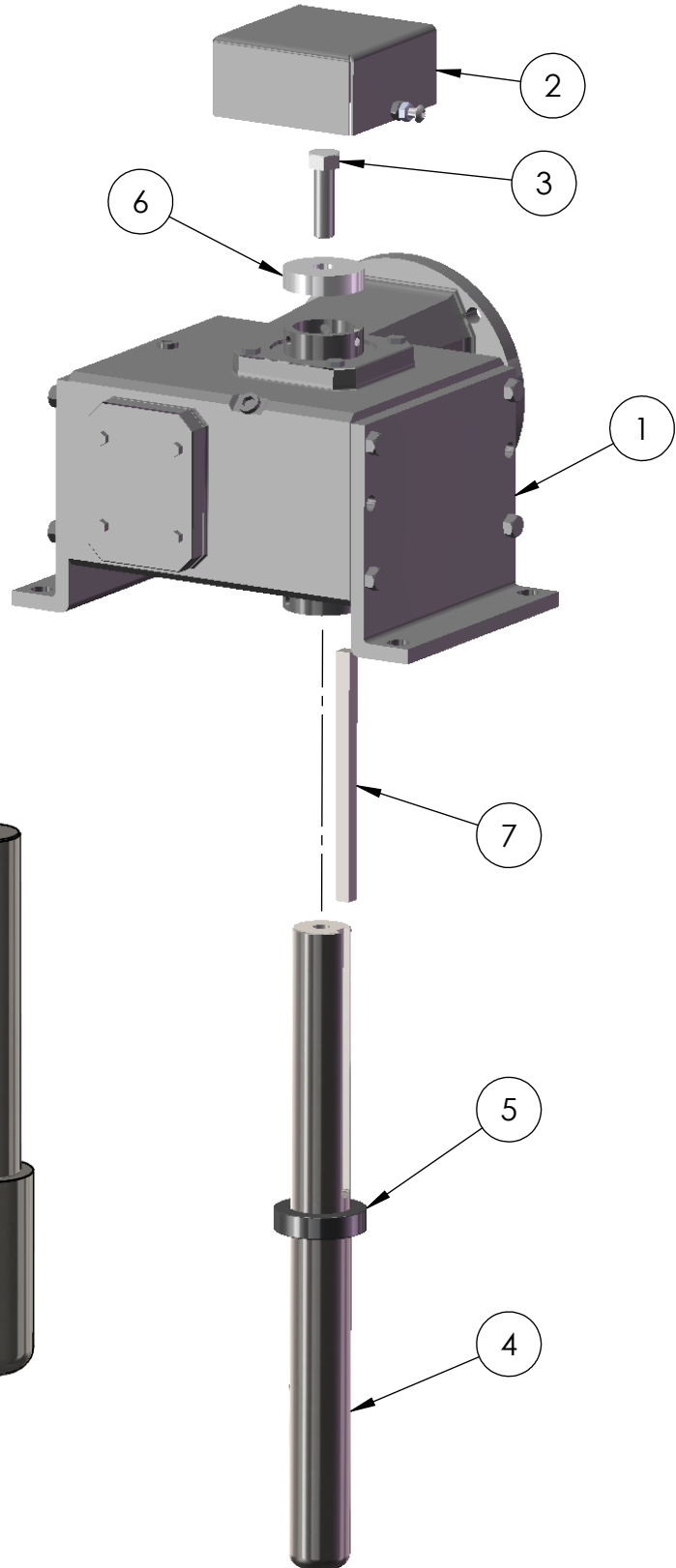

ALTERNATE CONST. OF SHAFT

7	1	KEY
6	1	THRUST WASHER
5	1	SHAFT COLLAR
4	1	MIXER SHAFT
3	1	HEX HEAD CAP SCREW
2	1	GUARD
1	1	GEARDIVE
ITEM NO.	QTY.	PART NAME

FOR REFERENCE ONLY

* ALL DIMENSIONS AND WEIGHTS ARE FOR REFERENCE ONLY UNLESS THE DRAWING IS CERTIFIED.

* ALL EQUIPMENT DESIGN AND APPLICATION DATA SHOWN HEREIN IS CONFIDENTIAL AND THE PROPERTY OF BRAWN MIXER. NO USE OR DISCLOSURE THEREOF MAY BE MADE WITHOUT OUR WRITTEN PERMISSION.



12838 Stainless Drive
Holland, MI 49424

PH: 616-399-5600
FAX: 616-399-3084

MIXER MODEL
BWG SHAFT ASSEMBLY

DIMENSION AND ASSEMBLY DRAWING

DRAWN BY: BSB DATE: 9/6/2018 © 2018

APPROVED BY: DATE:

DWG. NO. **A- TK0090** REV.