

## DESMI self-priming centrifugal pump Type VAC-2001

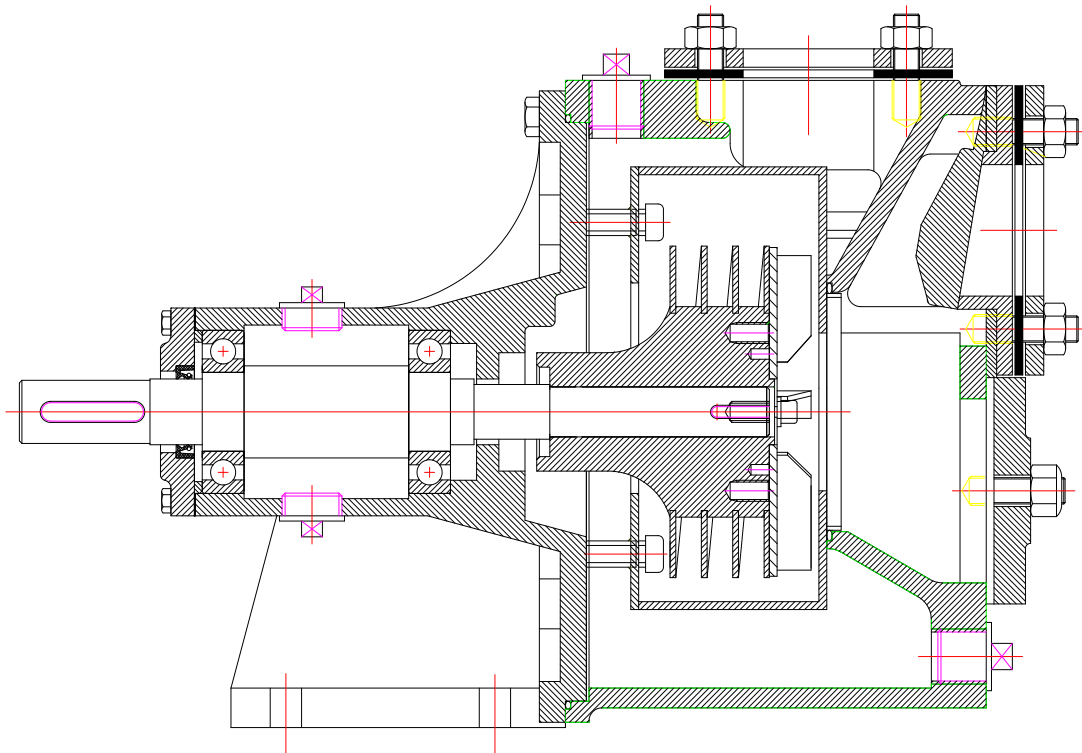

**DESMI PUMPING TECHNOLOGY A/S**  
Tagholm 1 – DK-9400 Nørresundby – Denmark

Tel.: +45 96 32 81 11  
Fax: +45 98 17 54 99  
E-mail: [desmi@desmi.com](mailto:desmi@desmi.com)  
Internet: [www.desmi.com](http://www.desmi.com)

Manual: T1451	Languag: English	Revision: F (11/09)
------------------	---------------------	------------------------



## Contents

<b>1. PRODUCT DESCRIPTION</b> .....	<b>3</b>
1.1 DELIVERY .....	3
<b>2. TECHNICAL DATA</b> .....	<b>3</b>
2.1 NAME PLATE .....	3
2.2 EXPLANATION OF THE TYPE NUMBER.....	3
2.3 TECHNICAL DESCRIPTION .....	4
<b>3. INSTALLATION</b> .....	<b>4</b>
3.1 MOUNTING/FASTENING.....	4
3.2 WIRING .....	6
<b>4. TRANSPORT/ STORAGE</b> .....	<b>6</b>
<b>5. DISMANTLING SEE DRAWING NO. 490230</b> .....	<b>7</b>
5.1 ACCESS TO IMPELLER AND ROTOR .....	7
5.2 DISMANTLING IMPELLER AND ROTOR.....	7
5.3 DISMANTLING ROTOR HOUSING AND REAR PLATE.....	7
5.4 DISMANTLING SHAFT SEAL.....	7
5.5 DISMANTLING SEAT.....	7
5.6 DISMANTLING SHAFT WITH BEARINGS.....	7
5.7 INSPECTION.....	7
<b>6. ASSEMBLING</b> .....	<b>7</b>
6.1 FITTING ROTOR HOUSING IN PUMP CASING.....	7
6.2 FITTING REAR PLATE FOR ROTOR HOUSING .....	7
6.3 FITTING SHAFT WITH BEARINGS .....	7
6.4 FITTING SHAFT SEAL.....	8
6.5 FITTING ROTOR .....	8
6.6 FITTING IMPELLER.....	8
6.7 FITTING BEARING BRACKET WITH REAR PLATE FOR ROTOR HOUSING.....	9
6.8 SHAFT.....	9
<b>7. FROST PROTECTION</b> .....	<b>9</b>
<b>8. DISMANTLING</b> .....	<b>9</b>
<b>9. START-UP</b> .....	<b>9</b>
9.1 STARTING .....	9
<b>10. SYSTEM BALANCING</b> .....	<b>10</b>
<b>11. INSPECTION AND MAINTENANCE</b> .....	<b>12</b>
11.1 DRAINING THE PUMP .....	12
11.2 BEARINGS .....	12
<b>12. REPAIRS</b> .....	<b>12</b>
12.1 ORDERING SPARE PARTS.....	12
<b>13. OPERATING DATA</b> .....	<b>12</b>
<b>14. EU DECLARATION OF CONFORMITY</b> .....	<b>13</b>
<b>15. INFORMATION RELEVANT FOR DISASSEMBLY OR DISPOSAL AT END-OF-LIFE</b> .....	<b>14</b>
<b>16. ASSEMBLY DRAWING</b> .....	<b>14</b>
<b>17. SPARE PARTS LIST</b> .....	<b>15</b>
<b>18. DIMENSIONAL SKETCH</b> .....	<b>16</b>

## 1. PRODUCT DESCRIPTION

This operation and maintenance instruction applies to the DESMI self-priming centrifugal pump, type VAC-2001. The pump is available with DN65 on the suction and pressure flanges.

The VAC-2001 pump is a single-stage self-priming centrifugal pump with horizontal inlet and vertical outlet at the top. The pump is equipped with a rotor which enables it to efficiently evacuate air from the suction hose. Further the pump has stainless steel shaft and mechanical shaft seal.

The pump is suitable for pumping clean and polluted liquids with temperatures between 0 and 80°C.

Max. number of revolutions is 3600 RPM.

The pump is particularly suitable for bilge pumping and for use in piping systems where large amounts of air have to be evacuated.

The VAC-2001 pump is a quality product manufactured in accordance with ISO 9001.

### 1.1 DELIVERY

- Check on delivery that the shipment is complete and undamaged.
- Defects and damages, if any, to be reported to the carrier and the supplier immediately in order that a claim can be advanced.

## 2. TECHNICAL DATA

### 2.1 NAME PLATE

Manufacturer:  
DESMI PUMPING TECHNOLOGY A/S  
DK-9400 Nørresundby  
Phone +45 96328111  
Fax +45 98175499  
e-mail: [desmi@desmi.com](mailto:desmi@desmi.com)  
<http://www.desmi.com>

TYPE: Pump type number  
CODE NO.: Pump item No.  
PUMP NO.: Pump No.  
IMP.: Impeller diameter  
WEEK/YEAR: Production week and year

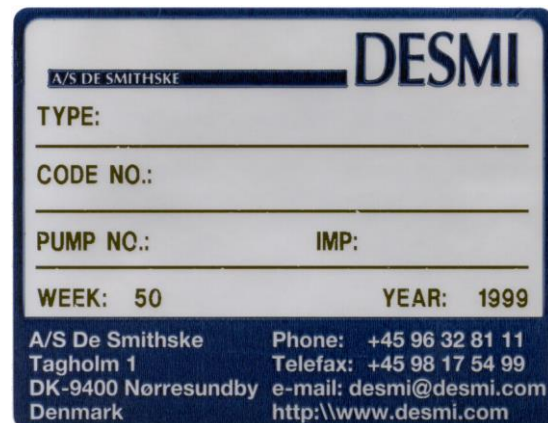

The pumps are manufactured in various material combinations which appear from the type number on the name plate.

### 2.2 EXPLANATION OF THE TYPE NUMBER

The VAC-2001 pump is provided with a name plate. The type number indicated on the name plate is built up as follows:

VAC-2001/M-R

- M : The material combination of the pump.
- R : The assembly combination of the pump.

M may be the following:

- A : Standard: Casing: GG20. Impeller: Stainless steel. Rotor: Stainless steel
- D : Casing: Rg5. Impeller: Stainless steel. Rotor: Stainless steel
- E : Special alloy.

The pumps can be delivered in other material combinations, which are agreed with the supplier.

R may be the following:

- 01 : With electromagnetic clutch
- 03 : With hydraulic motor
- 04 : V-belt pulley and disengaging clutch
- 07 : On base plate with petrol or diesel engine, or with electric motor
- 09 : With bare shaft end
- 10 : Special-tailored according to task

Any use of the pump is to be evaluated on the basis of the materials used in the pump. In case of doubt, contact the supplier.

Pumps in material combinations A are primarily used for fresh water.  
Pumps in material combination D are primarily used for seawater.

### 2.3 TECHNICAL DESCRIPTION

The noise level of the pump depends on the motor type supplied, as the noise from the pump can be calculated as the noise level of the motor + 2dB(A).

## 3. INSTALLATION

### 3.1 MOUNTING/FASTENING

The pump should be mounted and fastened on a solid base plate with a flat and horizontal surface to avoid distortion.

The pump must be mounted in such a way that the shaft centerline is horizontal.

When mounting a V-belt pulley on the pump a bore H7 is recommended. To facilitate the mounting the hub in the V-belt pulley may be heated to about 100°C after which the V-belt pulley is easily lead over the shaft towards the shoulder. Alternatively, the V-belt pulley may be mounted with a TAPER LOCK bush.

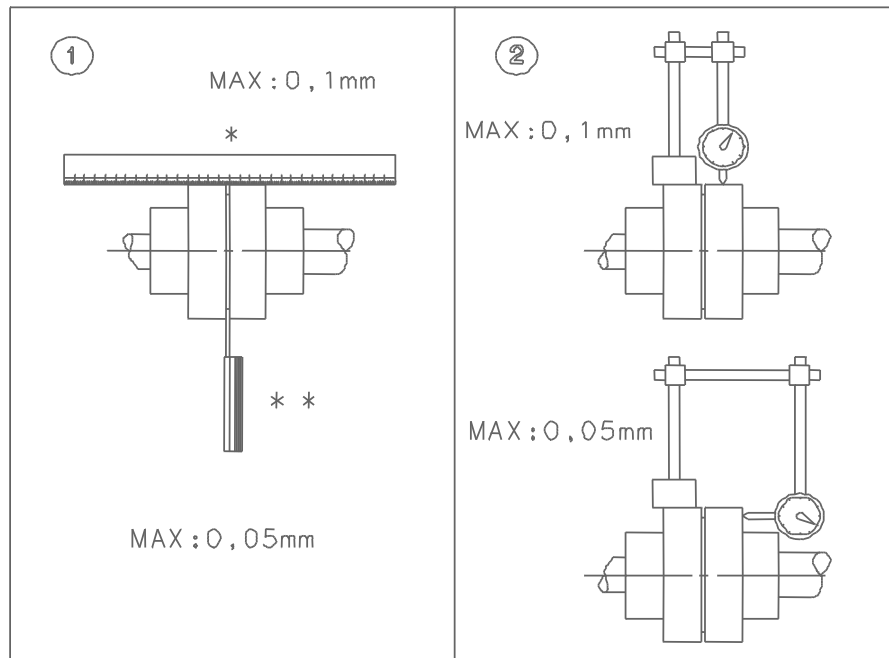

When dimensioning the V-belt pulley it is important to follow the rules of the DESMI nomograms for the pump size in question - contact DESMI.

Be careful when fitting the suction line to the pump so that it is absolutely tight, as even small leakages may impede the priming. When pumping polluted liquids a strainer is necessary. The strainer must be equipped with a sieve, the passage area of which is to be 3 x the area of the suction pipe. The mesh size is to be 1-3 mm smaller than the impeller gap of the pump in question.

In order to secure priming of the pump the pressure pipe is to be arranged so that water locks in the pipe are avoided.

If the pump is to be driven by a motor via a flexible coupling, motor and pump are to be placed on a common base plate. The following should be observed:

- Avoid distortion of the base plate.
- Avoid distortion in the piping system.
- Check that pump and motor are aligned correctly.

Two proposals for alignment are indicated above. The deviations mentioned cover a complete revolution of the coupling. The distance between the coupling halves is to be between 2 and 4 mm.



At installations pumping hot or very cold liquids, the operator must be aware that it is dangerous to touch the pump surface, and, consequently, he must take the necessary safety measures.

When connecting the pump and a prime mover the power transmission is to be equipped with a guard in accordance with the provisions of the COUNCIL DIRECTIVE.

## 3.2 WIRING



Wiring to be carried out by authorised skilled workmen according to the rules and regulations in force.

## 4. TRANSPORT/ STORAGE

The weights of the pumps are stated in the following table, and the pumps are to be lifted as shown below.

Pump	Weight [kg]
VAC-2001/A09	35
VAC-2001/A07 excl. electric motor	45

The pumps are to be stored in a dry place.

Before shipment the pump is to be fastened securely on pallets or the like.



The pump is to be lifted as shown here:

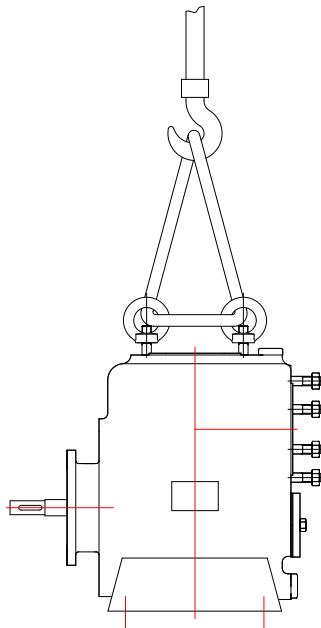

Screw lifting eyes into the pressure flange and mount lifting straps  
The lifting straps must not bear against sharp edges and corners.

## 5. DISMANTLING SEE DRAWING No. 490230

Before dismantling the pump, drain the bearing bracket of oil. Unscrew filling and drain plug (31) and drain the oil into a bucket.

### 5.1 ACCESS TO IMPELLER AND ROTOR

Remove M12 nuts (1), which hold the bearing bracket (22) to the pump casing. Pull the bearing bracket (22) to remove the complete bearing bracket with rotor, impeller, bearings, and shaft. Remove the O-ring (3).

### 5.2 DISMANTLING IMPELLER AND ROTOR

Remove impeller nut (20), washer (19) and lock washer (35). Pull the impeller (12) off the rotor. Pull the rotor off the shaft. Take care not to damage the shaft seal seat which is mounted in the rotor.

### 5.3 DISMANTLING ROTOR HOUSING AND REAR PLATE

Pull rotor housing (21) off the recess of the pump casing. Remove O-ring (8). Unscrew Allen screws (16) and remove the rear plate from the bearing bracket.

### 5.4 DISMANTLING SHAFT SEAL

Before dismantling shaft seal remove key (29). Now pull the shaft seal off the shaft.

### 5.5 DISMANTLING SEAT

Pull the shaft seal seat carefully out of the recess of the rotor hub.

### 5.6 DISMANTLING SHAFT WITH BEARINGS

Remove key (30) from the shaft and remove screws (33). Pull bearing cover (27) with oil sealing ring (26) off the shaft. Remove paper gasket (32). The shaft with bearings can now be pulled out of the bearing bracket allowing inspection of the bearings.

### 5.7 INSPECTION

When the pump has been dismantled, check the following parts for wear and damage:

- |                          |   |
|--------------------------|---|
| - Sealing ring/impeller: | Max. clearance 0.4-0.5 mm measured in radius  |
| - Shaft seal:            | Check wear ring and seat for flatness and cracks.<br>Check the rubber parts for elasticity and scratches. |
| - Bearing:               | Replace in case of wear and noise   |
| - Rotor:                 | Check the rotor for damages   |

## 6. ASSEMBLING

### 6.1 FITTING ROTOR HOUSING IN PUMP CASING

Place O-ring (8) on the collar of the rotor housing and press into place in the inlet of the pump casing.

### 6.2 FITTING REAR PLATE FOR ROTOR HOUSING

Fasten rear plate to the bearing bracket with Allen screws (16).

### 6.3 FITTING SHAFT WITH BEARINGS

Lead the shaft into the bearing bracket. Mount oil sealing ring (26) in bearing cover. Place paper gasket (32) on the bearing cover and lead the cover over the shaft. Fasten with screws (33). Mount the key (30) in the shaft.

## 6.4 FITTING SHAFT SEAL

Before fitting the seat, clean the recess in the rotor. When fitting the seat, remove the protective coating, if any, without scratching the lapped surface. Dip the outer rubber ring of the seat into soapy water. Now press the seat into place with the fingers and check that all parts are correctly imbedded. If it is necessary to use tools for assembling, protect the sliding surface of the seat to prevent it from being scratched or cut. Lubricate the inner diameter of the slide ring rubber bellows with soapy water and push it over the shaft. The use of a fitting bush as shown on the below assembly drawing is recommended to avoid that the rubber bellows is cut. Push the slide ring over the shaft with the hand. If the rubber bellows is tight, use a fitting tool and take care that the slide ring is not damaged.

Fitting bush

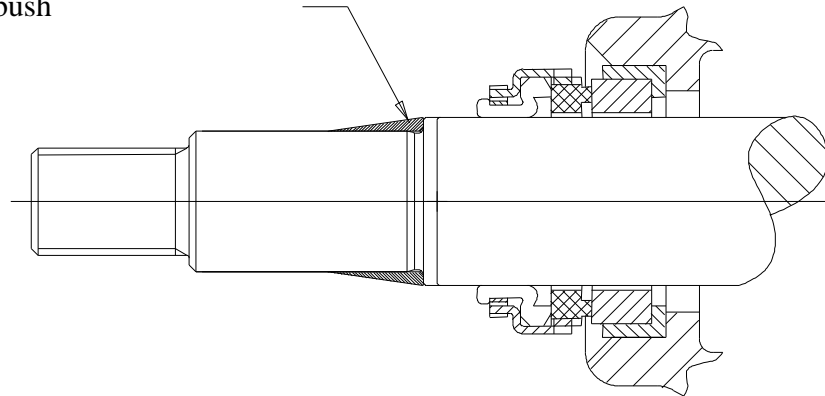

If the carbon ring is not fixed, it is important to check that it is fitted correctly, i.e. the chamfered/lapped side is to face the seat. The carbon ring can be held by a little grease.

## 6.5 FITTING ROTOR

Fit key (29) in the shaft and lead the rotor over the shaft and all the way to the shoulder of the shaft.

## 6.6 FITTING IMPELLER

The two guide pins (28) are placed in the front of the rotor, and the impeller is placed on the rotor in such a way that the two guide pins are located in the impeller holes. Secure the impeller with a disc (19), a lock washer (35) and an Allen screw (20).



## 6.7 FITTING BEARING BRACKET WITH REAR PLATE FOR ROTOR HOUSING

Place the O-ring (3) that seals between pump casing and bearing bracket on the bearing bracket where it can be held with a little silicone grease. Lead the bearing bracket into place and fasten with screws (1). Mount filling and drain plug (31) and fill bearing bracket with oil (SAE 15W40) until half the shaft is covered.

## 6.8 SHAFT

When the pump has been assembled, check that the shaft rotates freely.

## 7. FROST PROTECTION

Pumps which are not in operation during frost periods are to be drained to avoid frost damage. Remove the filling and drain plug (10) at the bottom to empty the pump. Alternatively, it is possible to use anti-freeze liquids in normal constructions.

## 8. DISMANTLING



Before dismantling the pump make sure that it has stopped. Empty the pump of liquid before it is dismantled from the piping system. If the pump has been pumping dangerous liquids you are to be aware of this and take the necessary safety measures. If the pump has been pumping hot liquids, take great care that it is drained before it is removed from the piping system. If cold or very hot liquids have been pumped, the operator must be aware that it is dangerous to touch the pump surface and he must, consequently, take the necessary safety measures.

## 9. START-UP

A self-priming centrifugal pump will not function until the pump casing has been filled with liquid.



The liquid also serves as coolant for the shaft seal. In order to protect the shaft seal the pump must not run dry.

WARNING

For safety reasons the pump is only allowed to operate against closed discharge valve for a short time (max. 5 minutes and at a max. temperature of 80°C for standard pumps). Otherwise there is a risk of damage to the pump and, at worst, of a steam explosion. If the pump is not monitored, the installation of a safety device is recommended.

### 9.1 STARTING

Before starting the pump check that

- the shaft rotates freely without noise
- the pump casing is filled with liquid.

Start the pump for a moment to check direction of rotation. If the direction is correct (i.e. in the direction of the arrow), the pump may be started.

## 10. SYSTEM BALANCING

It is often difficult to calculate a manometric delivery head in advance. It is, however, decisively important to the quantity of liquid delivered.

A considerably smaller delivery head than expected will increase the quantity of liquid delivered, causing increased power consumption and perhaps cavitation in pump and piping. In the pump the impeller may show signs of heavy erosion caused by cavitation (corrosion) which may at times render an impeller unfit for use in a very short time. Not unusually do similar erosions occur in pipe bends and valves elsewhere in the piping system.

Therefore, after start-up, it is necessary to check either the quantity of liquid delivered or the power consumption of the pump e.g. by measuring the current intensity of the connected motor. Together with a reading of the differential pressure the quantity of water delivered can be determined against the characteristics of the pump.

In cases where the liquid flow of the pump has to be reduced a valve in the piping system is the most common solution. This valve **always** has to be placed on the suction side of the pump - never on the delivery side.

Should the pump not function as intended, please proceed according to the fault-finding list. Bear in mind, though, that the pump was carefully checked and tested at the factory and that the majority of faults stem from the piping system.

FAULT	CAUSE	REMEDY
The pump does not prime	<ol style="list-style-type: none"> <li>1. The pump is not filled with liquid</li> <li>2. Leaking non-return valve in pump</li> <li>3. Wrong direction of rotation</li> <li>4. Air is drawn in because of too little liquid or leaking suction line</li> <li>5. Liquid lock in outlet line</li> <li>6. Temperature of liquid too high</li> <li>7. Air cannot escape on pressure side</li> </ol>	<p>Fill pump casing with liquid</p> <p>Remove foreign body in valve/Remove any coating on mating faces</p> <p>Change direction of rotation</p> <p>Lower suction pipe/ Tighten suction line</p> <p>Change the pressure line so that the air can pass out freely</p> <p>Replace liquid in pump casing/Wrong dimensioning/Contact DESMI</p> <p>Ventilate the system</p>
The pump has no or too low capacity	<ol style="list-style-type: none"> <li>1. Wrong direction of rotation</li> <li>2. Piping system choked</li> <li>3. The pump is choked</li> <li>4. Suction line leaks Pump takes air</li> <li>5. Suction lift too high</li> <li>6. Pump and piping system wrongly dimensioned</li> </ol>	<p>Change direction of rotation to clockwise when viewed from shaft end (the direction of the arrow)</p> <p>Clean or replace</p> <p>Clean the pump</p> <p>Find the leakage/repair the fault, non-return valve not submerged</p> <p>Check data sheet Q/H curve and NPSH or contact DESMI</p> <p>As 5</p>
The pump uses too much power	<ol style="list-style-type: none"> <li>1. Counter-pressure too low</li> <li>2. The liquid is heavier than water</li> <li>3. Foreign body in pump</li> <li>4. Electric motor is running on 2 phases</li> </ol>	<p>Insert orifice plate or check valve/Contact DESMI</p> <p>Contact DESMI</p> <p>Dismantle the pump, remove the cause</p> <p>Check fuses, cable connection, and cable</p>
The pump makes noise	<ol style="list-style-type: none"> <li>1. Cavitation in pump</li> </ol>	<p>Suction lift too high/ Suction line wrongly dimensioned/Liquid temperature too high</p>

## 11. INSPECTION AND MAINTENANCE

Inspect the shaft seal for leaks at regular intervals.

This is done by checking the oil inside the bearing bracket. If the shaft seal is leaking the oil becomes white.

- Before inspection of a pump without guard check that the pump cannot be .....started unintentionally.
- The system is to be without pressure and drained of liquid.
- The repairman must be familiar with the type of liquid that has been pumped as well as the safety measures he is to take when handling the liquid.

### 11.1 DRAINING THE PUMP

When the piping system has been drained, note that there is still liquid in the pump. Remove the liquid by dismantling the filling and drain plug (10) at the bottom of the pump.

### 11.2 BEARINGS

The pump is equipped with deep groove ball bearings with a nominal life of 25,000 working hours when direct coupled to electric motor, whereas the nominal life with overhanging V-belt drive is about 10,000 working hours. The bearings are oil lubricated and they only require that the oil level in the bearing bracket is correct. However, they should be replaced in case of noise or bearing wear. In connection with a leaking shaft seal where water has penetrated the bearings, inspect these for damages and replace is necessary.

## 12. REPAIRS

### 12.1 ORDERING SPARE PARTS

When ordering spare parts please always state pump type and pump no. (available from the name plate of the pump). See also spare parts drawing with item nos.

## 13. OPERATING DATA

The following working pressures are allowed

PUMP	VAC-2001
Pressure [mWC]	35

(10.2 mWC = 1 bar)

The above-mentioned max. working pressure is **NOT** valid for pumps approved by a classification society. Pumps approved by classification societies have been pressure tested according to the requirements of these societies, i.e. a test pressure of 1.5 x the permissible working pressure. The test pressure is stated in the test certificate and stamped into the discharge flange of the pump.

## 14. EU DECLARATION OF CONFORMITY

DESMI PUMPING TECHNOLOGY A/S, hereby declare that our pumps of the type VAC-2001 are manufactured in conformity with the following essential safety and health requirements in the COUNCIL DIRECTIVE 2006/42/EC on machines, Annex 1.

The following harmonized standards have been used:

EN/ISO 13857:2008	Safety of machinery. Safety distances to prevent danger zones being reached by the upper limbs
EN 809:1998 + A1:2009	Pumps and pump units for liquids – Common safety requirements
EN12162:2001+A1:2009	Liquid pumps – Safety requirements – Procedure for hydrostatic testing
EN 60204-1:2006/A1:2009	Safety of machinery – Electrical equipment of machines (item 4, General requirements)

Pumps delivered by us connected with prime movers are CE-marked and comply with the above requirements.

Pumps delivered by us without prime movers (as partly completed machinery) must only be used when the prime mover and the connection between prime mover and pump comply with the above requirements.

Nørresundby, March 05 2014



Henrik Mørkholt Sørensen  
Managing Director

DESMI Pumping Technology A/S  
Tagholm 1  
9400 Nørresundby

## 15. INFORMATION RELEVANT FOR DISASSEMBLY OR DISPOSAL AT END-OF-LIFE

No damage materials are used in DESMI pumps – please refer to DESMI Green Passport (can be sent on request – contact a DESMI sales office) – i.e. common recycling companies can handle the disposal at end-of-life. Alternatively the pump and motor can be returned to DESMI at end-of-life for safe recycling.

## 16. ASSEMBLY DRAWING

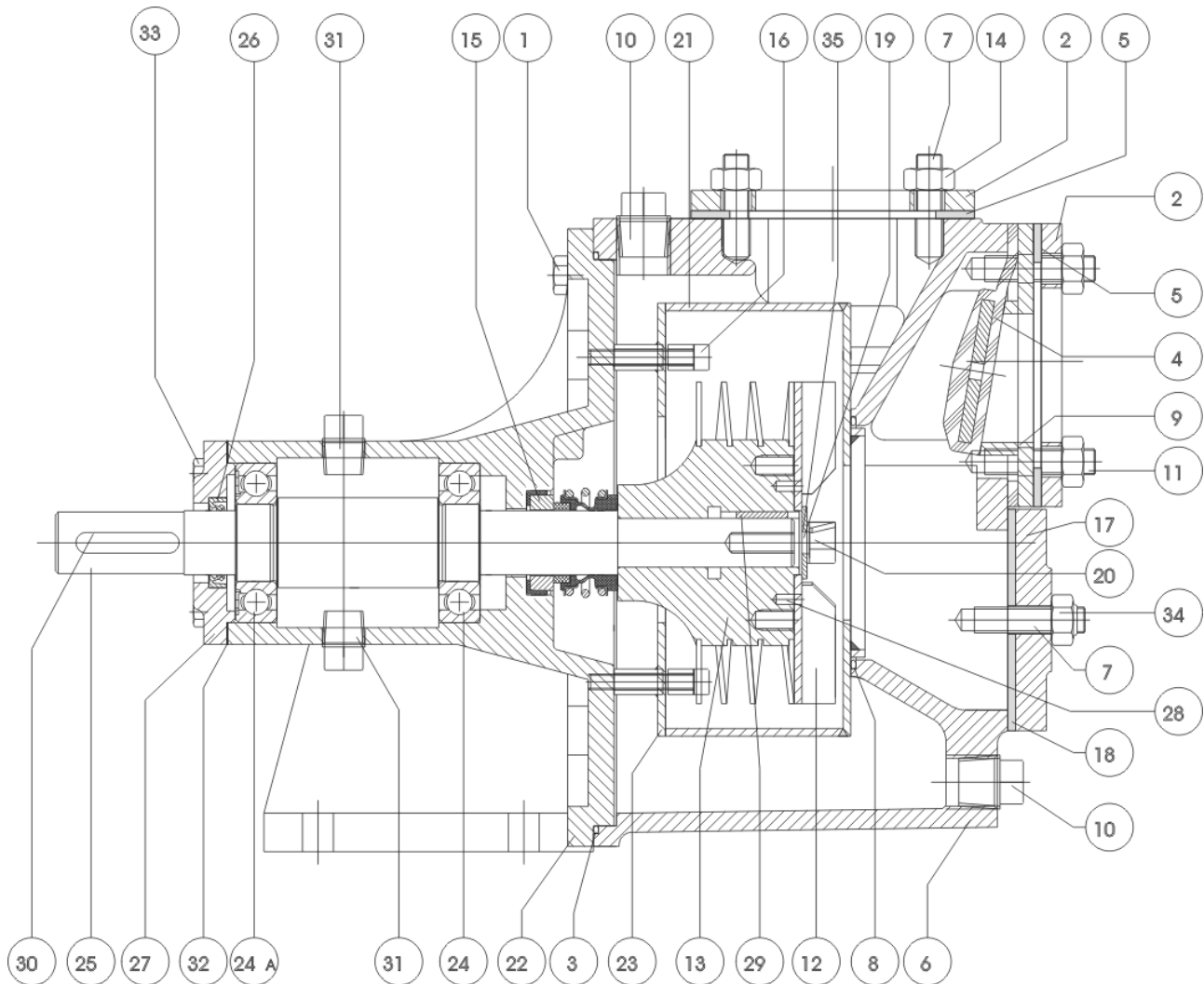

## 17. SPARE PARTS LIST

Pos. No.	Description	Qty.	Item No.
01	Allen screw M8x25	6	705254
02	Counter flange	2	190534
03	O-ring	1	710952
04	Check valve	1	190543
05	Flange gasket	2	190542
06	Pump casing	1	590790
07	Stud M10x25 A4	6	700218
08	O-ring	1	710953
09	Seat for check valve	1	590800
10	Filling and drain plug 1/2"	2	705020
11	Stud M10x30 A4	4	700219
12	Impeller	1	190535
13	Rotor	1	190537
14	Nut M10	8	704012
15	Shaft seal	1	710949
16	Allen screw M6x40	4	704180
17	Inspection cover	1	590810
18	Gasket for inspection cover	1	190541
19	Disc M8	1	710954
20	Allen screw M8x20 A4	1	704367
21	Rotor housing	1	190538
22	Bearing bracket	1	590840
23	Rear plate	1	190536
24	Ball bearing 6206	1	700982
24A	Ball bearing 6206 1RS	1	702387
25	Shaft	1	591300
26	Oil sealing ring	1	700835
27	Bearing cover	1	590830
28	Guide pin ø4x8	2	706284
29	Key for rotor	1	700012
30	Key for shaft	1	700899
31	Filling and drain plug 3/8"	2	2037505
32	Paper gasket	1	190544
33	Stud M6x20	4	706287
34	Nut Nyloc M10	2	703135
35	Lock washer M8	1	710948

## 18. DIMENSIONAL SKETCH

