

MOUNTING BOLT HOLES STRADDLE CENTERLINE

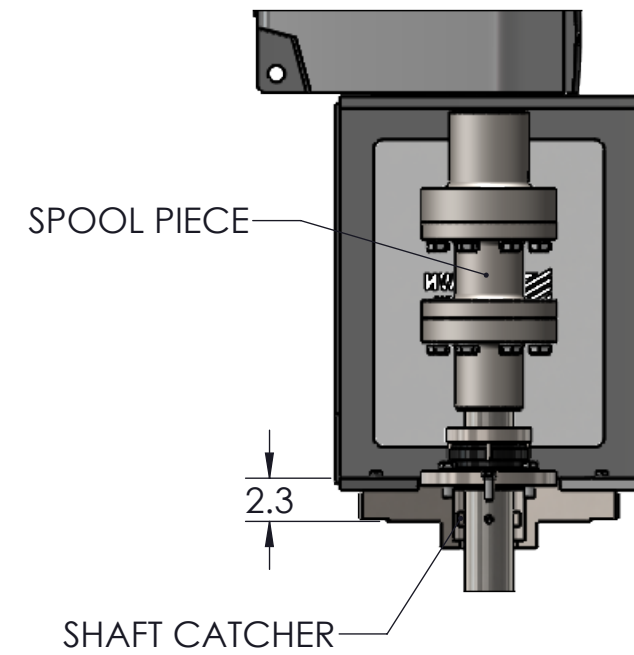

OPTIONAL AF3 IMPELLER

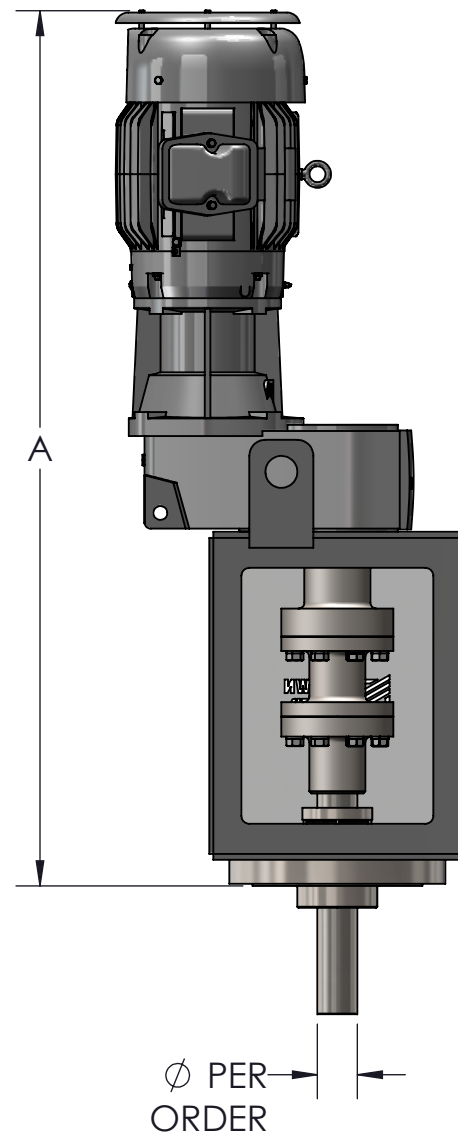

NOTES:

1. BASIC WEIGHT DOES NOT INCLUDE SHAFT, IMPELLER(S) OR MOTOR.
2. STANDARD FLANGE SIZES SHOWN. OTHER SIZES ARE OPTIONALLY AVAILABLE.
3. ALL DIMENSIONS ARE IN INCHES.

DIMENSIONS			
CASE SIZE	A	BASIC WGT. (LBS)	STD. ANSI FLANGE
2	43.5	285	8" 150#
3	45.5	330	8" 150#
4	51.5	440	8" 150#
5	56.2	690	8" 150#
6	76.3	1,125	10" 150#
7	78.5	1,280	10" 150#
8	87.2	1,860	12" 150#
9	89.1	2,690	14" 150#

FOR REFERENCE ONLY

* ALL DIMENSIONS AND WEIGHTS ARE FOR REFERENCE ONLY UNLESS THE DRAWING IS CERTIFIED.

* ALL EQUIPMENT DESIGN AND APPLICATION DATA SHOWN HEREIN IS CONFIDENTIAL AND THE PROPERTY OF BRAWN MIXER. NO USE OR DISCLOSURE THEREOF MAY BE MADE WITHOUT OUR WRITTEN PERMISSION.



12838 STAINLESS DR
HOLLAND, MI 49424
PH: 616-399-5600
FAX: 616-399-3084

MIXER MODEL
BTO - MECHANICAL SEAL
CLOSED TANK NOZZLE MOUNTED MIXER
DIMENSION AND ASSEMBLY DRAWING

DRAWN BY: BSB DATE: 9/13/2018 © 2018
APPROVED BY: DATE:

DWG. NO. **B- TK0024** REV.