

# DSS dosing skid station

Installation and operating instructions

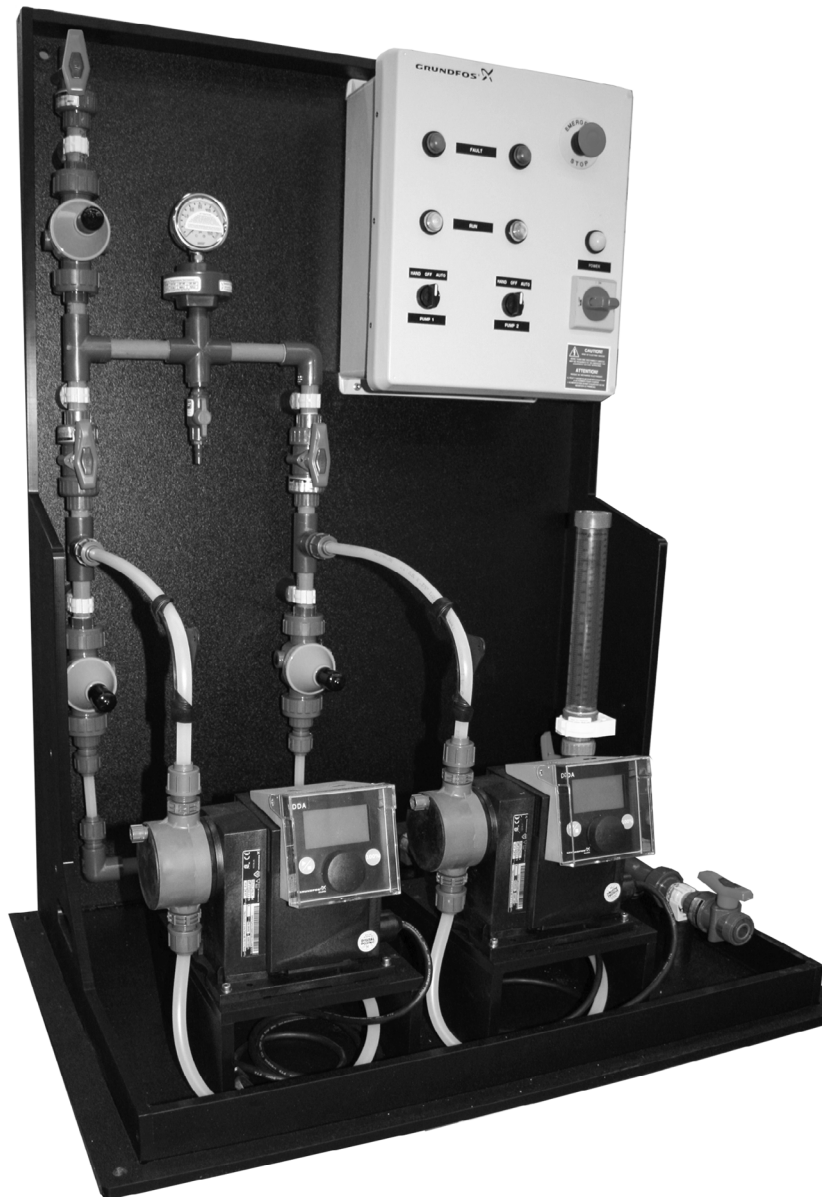

## Original installation and operating instructions

## CONTENTS

	Page
<b>1. Limited warranty</b>	<b>2</b>
<b>2. General information</b>	<b>2</b>
2.1 Type key	3
<b>3. Safety information</b>	<b>4</b>
3.1 Target group	4
3.2 Symbols used in this document	4
3.3 Safety-related symbols on the product	4
3.4 Safety instructions for the user	4
3.5 Unauthorized changes	4
3.6 Safety of the system in the event of product failure	4
3.7 Working with chemicals	5
<b>4. Product introduction</b>	<b>5</b>
4.1 Certificates	5
4.2 Intended use	5
4.3 Improper use	5
4.4 Product overview and dimensions	5
4.5 Standard DSS pipe and instrumentation diagram for 1-, 2- and 3-pump systems	7
<b>5. Technical data</b>	<b>8</b>
<b>6. Transport and storage</b>	<b>8</b>
<b>7. Installation</b>	<b>9</b>
7.1 Electrical connection	9
<b>8. Startup</b>	<b>12</b>
8.1 Calibration	12
<b>9. Operation</b>	<b>12</b>
<b>10. Maintenance</b>	<b>12</b>
10.1 Safety instructions	12
10.2 Maintenance intervals	13
<b>11. Long-term shutdown</b>	<b>13</b>
<b>12. Disposal</b>	<b>13</b>



## Warning

Prior to installation, read these installation and operating instructions. Installation and operation must comply with local regulations and accepted codes of good practice.



## Warning

Read the installation and operating instructions of the DSS components (dosing pumps, back pressure and pressure relief valves, pulsation dampers, calibration columns and control panels)

## 1. Limited warranty

Products manufactured by GRUNDFOS PUMPS CORPORATION (Grundfos) are warranted to the original user only to be free of defects in material and workmanship for a period of 24 months from date of installation, but not more than 30 months from date of manufacture. Grundfos' liability under this warranty shall be limited to repairing or replacing at Grundfos' option, without charge, FOB Grundfos' factory or authorized service station, any product of Grundfos' manufacture. Grundfos will not be liable for any costs of removal, installation, transportation, or any other charges which may arise in connection with a warranty claim. Products which are sold but not manufactured by Grundfos are subject to the warranty provided by the manufacturer of said products and not by Grundfos' warranty. Grundfos will not be liable for damage or wear to products caused by abnormal operating conditions, accident, abuse, misuse, unauthorized alteration or repair, or if the product was not installed in accordance with Grundfos' printed installation and operating instructions.

To obtain service under this warranty, the defective product must be returned to the distributor or dealer of Grundfos' products from which it was purchased together with proof of purchase and installation date, failure date, and supporting installation data. Unless otherwise provided, the distributor or dealer will contact Grundfos or an authorized service station for instructions. Any defective product to be returned to Grundfos or a service station must be sent freight prepaid; documentation supporting the warranty claim and/or a Return Material Authorization must be included if so instructed.

GRUNDFOS WILL NOT BE LIABLE FOR ANY INCIDENTAL OR CONSEQUENTIAL DAMAGES, LOSSES, OR EXPENSES ARISING FROM INSTALLATION, USE, OR ANY OTHER CAUSES. THERE ARE NO EXPRESS OR IMPLIED WARRANTIES, INCLUDING MERCHANTABILITY OR FITNESS FOR A PARTICULAR PURPOSE, WHICH EXTEND BEYOND THOSE WARRANTIES DESCRIBED OR REFERRED TO ABOVE.

Some jurisdictions do not allow the exclusion or limitation of incidental or consequential damages and some jurisdictions do not allow limit actions on how long implied warranties may last. Therefore, the above limitations or exclusions may not apply to you. This warranty gives you specific legal rights and you may also have other rights which vary from jurisdiction to jurisdiction.

## 2. General information

These installation and operating instructions apply to Grundfos DSS (dosing skid station) systems equipped with Grundfos dosing pumps.

The proper functioning of a DSS system depends on the following points:

- correct operation
- regular maintenance
- calibration of the pump after installing the service kit and periodic re-calibration of the pump
- installation of service kit as recommended by individual DSS component manuals, ie manuals for dosing pumps, back pressure and pressure relief valves.

## 2.1 Type key

### Example

DSS-S2-DDA -l/h-bar- PEF-J-B N N N -P 50 50 W

#### Dosing skid system

S = Standard  
C = Custom

#### Pumps per skid

1 = One pump  
2 = Two pumps  
3 = Three pumps  
(N) = Any other number of pumps

#### Pump model

DDA  
DDC  
DDE  
DME  
DDI  
DMH  
DMX

#### Pump performance

flow (l/h) - pressure (bar)

#### Base material

P = High-density polyethylene  
S = Stainless steel  
C = Carbon steel

#### Gasket material

E = EPDM  
V = Viton (FKM)  
T = Teflon (PTFE)

#### Mounting

F = Floor or base mounted skid  
W = Wall-mounted panel  
E = Wall-mounted with enclosure

#### Control panel

J = Junction box (terminal strip/On Off)  
C = Full control panel (Hand-Off-Auto (HOA))  
P = Power plugs only  
N = No control of any kind  
S = Special custom panel

#### Pipe connection

N = NPT  
W = Weld (solvent, socket, butt, fusion)  
C = Compression  
F = Flange

#### Outlet pipe size

50 = 1/2"  
75 = 3/4"  
10 = 1"  
15 = 1 1/2"

#### Inlet pipe size

50 = 1/2"  
75 = 3/4"  
10 = 1"  
15 = 1 1/2"

#### Pipe material

P = PVC  
C = CPVC  
F = PVDF  
S = Stainless steel

#### Extra control cables

B = Both relay output and analog output (DDA and DMH AR)  
R = Relay output  
A = Analog output (DDA and DMH AR)  
S = Remote stop (DME)  
T = Both relay output and remote stop (DME)  
N = No extra, or none for B variant pumps

#### Instrumentation

P = Pressure transducer  
N = No instrumentation

#### Accessories

D = Pulsation damper  
N = No accessories  
E = E-box  
B = Both an E-box and pulsation damper

#### Back pressure or pressure relief valves

M = Multifunction valve  
B = Back pressure and pressure relief valves

### 3. Safety information

Non-observance of the safety instructions may have dangerous consequences for the staff, the environment and the product and may result in the loss of any claims for damages.

Should you require further information, please contact Grundfos.

#### 3.1 Target group

These installation and operating instructions contain general instructions that must be observed during installation, startup, operation and maintenance of the product. The responsible staff must read these installation and operating instructions prior to any work at the product. These installation and operating instructions must be available at the installation site at all times.

##### 3.1.1 Qualification and training of staff

The staff responsible for the installation, startup, operation and maintenance must be qualified for these tasks. Areas of responsibility, levels of authority and the supervision of the staff must be precisely defined by the operating company. If necessary, the staff must be trained.

##### 3.1.2 Obligations of the operating company

- Observe the local safety regulations.
- Instruct the operating staff.
- Provide the stipulated safety equipment and personal protective equipment.
- Arrange regular maintenance.

##### 3.1.3 Obligations of the user

- Read this manual thoroughly before putting the product into operation.
- Observe the recognized health and safety regulations as well as the accident prevention regulations.
- Wear protective equipment in accordance with national health and safety regulations when working at the system and handling chemicals.

#### 3.2 Symbols used in this document



Warning

If these safety instructions are not observed, it may result in personal injury.







If these safety instructions are not observed, it may result in malfunction or damage to the equipment.



Notes or instructions that make the job easier and ensure safe operation.

#### 3.3 Safety-related symbols on the product

Symbol	Description
	Indication of universally dangerous spot.
	In case of emergency and prior to all maintenance work and repairs, take the mains plug out of the mains supply.
	The product complies with electrical safety class II.
	Connection for deaeration hose at dosing head. If the deaeration hose is not correctly connected, danger will arise due to possible leakage of dosing medium.

All signs and symbols on the product must be observed and kept legible.

#### 3.4 Safety instructions for the user

Warning

Observe the local regulations for work safety.

Observe the safety data sheets of the supplier of chemicals.

All work on DSS systems must be carried out by authorized and qualified staff.

Wear protective clothing when working on DSS systems.



#### 3.5 Unauthorized changes

Do not make changes of DSS systems without prior consent of or agreement with the supplier.

Use only original accessories and original spare parts. Use of other parts or modification of DSS systems can result in malfunction of the product.

#### 3.6 Safety of the system in the event of product failure

Use appropriate monitoring and control devices in order to ensure the overall safety of the system in case the product fails.

Warning

Danger of personal injury due to contact with chemicals.

Make sure that leaking chemicals do not cause personal injury or damage to property.

We recommend installation of leakage monitoring solutions and drip trays.



### 3.7 Working with chemicals



#### Warning

Danger of personal injury due to contact with chemicals.

Wear the stipulated personal protective equipment (protective clothing, goggles, respirator etc.) when handling chemicals.

Observe the chemicals manufacturer's safety data sheets and safety instructions of the chemicals used.

Make sure that parts in contact with the chemicals are resistant to the chemicals under the specific operating conditions.

#### Caution

Should you have questions regarding the material of construction of the Grundfos equipment, please contact Grundfos.

## 4. Product introduction

DSS systems consist of one or more dosing pumps mounted on a base together with optional equipment. See section [4.4 Product overview and dimensions](#).

Standard DSS systems are designed according to the variants available in the type key. Customized systems are designed as customer-specified products.

### 4.1 Certificates

Depending on the DSS model, certificates and approvals will differ. Please refer to the pump and control panel installation and operating instructions specific to the installed DSS system.

### 4.2 Intended use

- DSS systems are intended for media that are compatible with the DSS materials of construction.
- The operating safety of DSS systems is only ensured, if they are used for the specified application and media, and in accordance with the values mentioned in section [5. Technical data](#). The specified limit values must not be exceeded.
- DSS systems may only be operated by technical staff in accordance with the installation and operating instructions.
- Modifications to DSS systems are only permitted with the consent of the manufacturer. Original spare parts and accessories approved by the manufacturer are safe to use.



#### Warning

Any usage other than that described here is not intended. Grundfos accepts no liability for any injuries or damage resulting from improper use.

### 4.3 Improper use

- DSS systems are not intended for dosing explosive, gaseous, highly viscous, solid media, or media containing abrasive or long-fibred particles.
- DSS systems are not intended for operation in other conditions than specified in the agreement with the customer or described in section [5. Technical data](#).



#### Warning

Any improper use can lead to personal injury and damage to the equipment.

#### Note

Observe the freezing and boiling points of the dosing medium at operating pressure. Observe the temperatures specified.

The operational safety of the product is only guaranteed, if it is used in accordance with section [4.2 Intended use](#).

- The product must not be used for media that are not specified in the agreement between Grundfos and the customer.
- The product must not be used in potentially explosive areas.
- The product must not be used in food-processing systems.
- The product must not be used if it is damaged.
- The product must not be used after improper repair.
- The product must not be used after unauthorized modification.

### 4.4 Product overview and dimensions

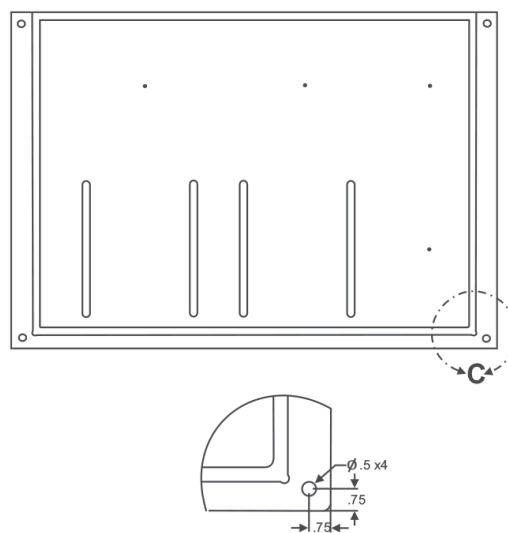

Typical for all standard skids

Fig. 1 DSS mounting holes

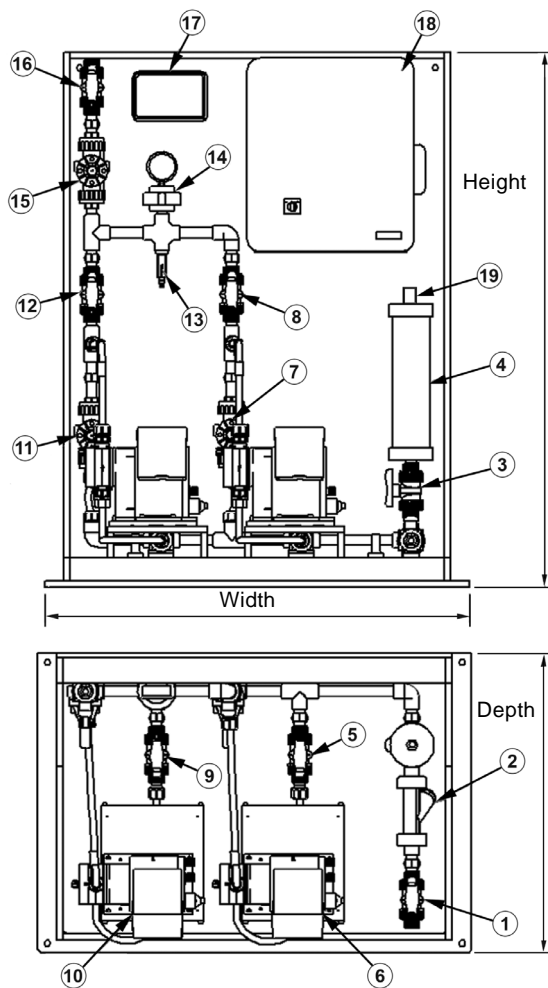

TM06 5481 1115

Fig. 2 Example of a DSS system

DSS system dimensions			
	Height [inches]	Width [inches]	Depth [inches]
Simplex	43	24	23.5
Duplex	43	34	23.5
Triplex	43	46	23.5

Pos.	Description
1	Inlet isolating valve
2	Y strainer
3	Isolating valve
4	Calibration column
5	Inlet isolating valve
6	Dosing pump
7	Pressure relief valve
8	Outlet isolating valve
9	Inlet isolating valve
10	Dosing pump
11	Pressure relief valve
12	Outlet isolating valve
13	Sample valve or bleed valve
14	Pressure gauge with diaphragm gauge guard
15	Back pressure valve
16	Outlet isolating valve
17	Nameplate
18	Junction box or Hand-Off-Auto panel (HOA) (optional)
19	Calibration column overflow accessory

4.5 Standard DSS pipe and instrumentation diagram for 1-, 2- and 3-pump systems

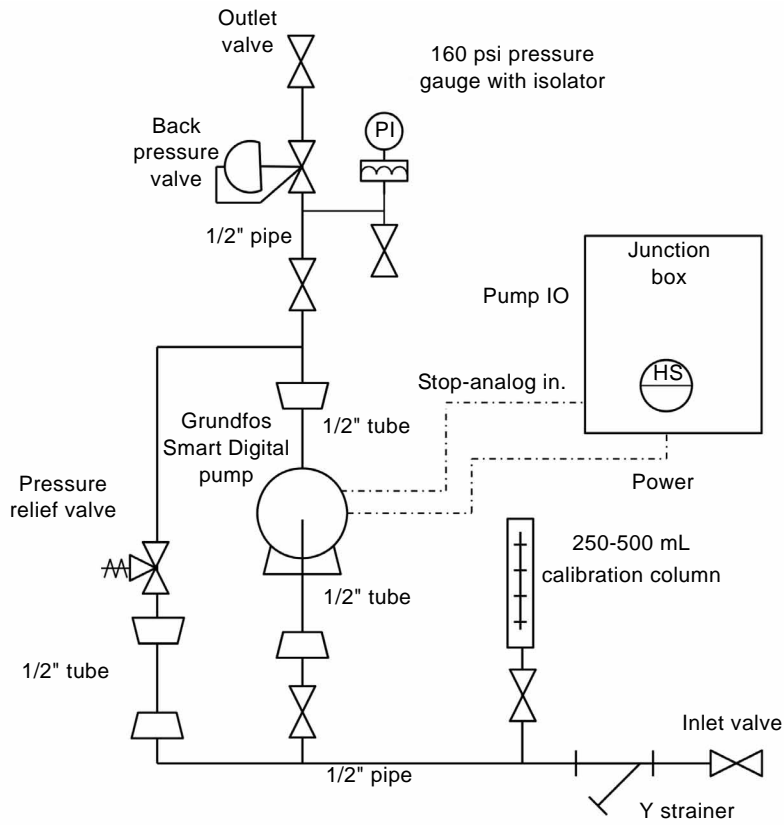

TM06 6241 0216

Fig. 3 Simplex DSS with junction box, see pos. 18 in fig. 2

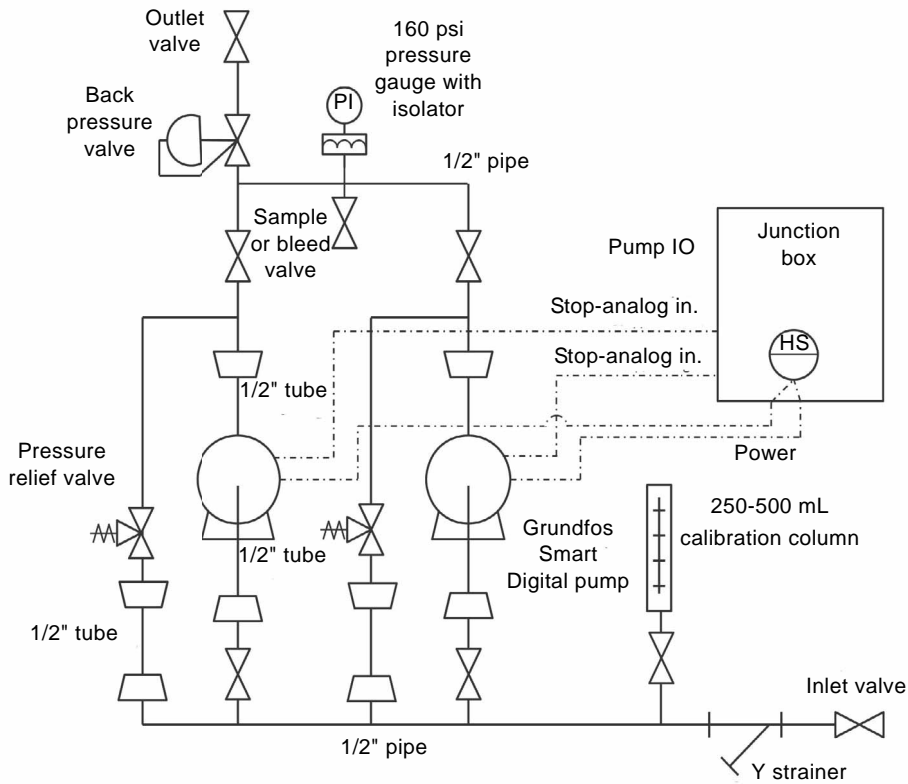

TM06 6242 0216

Fig. 4 Duplex DSS with junction box, see pos. 18 in fig. 2

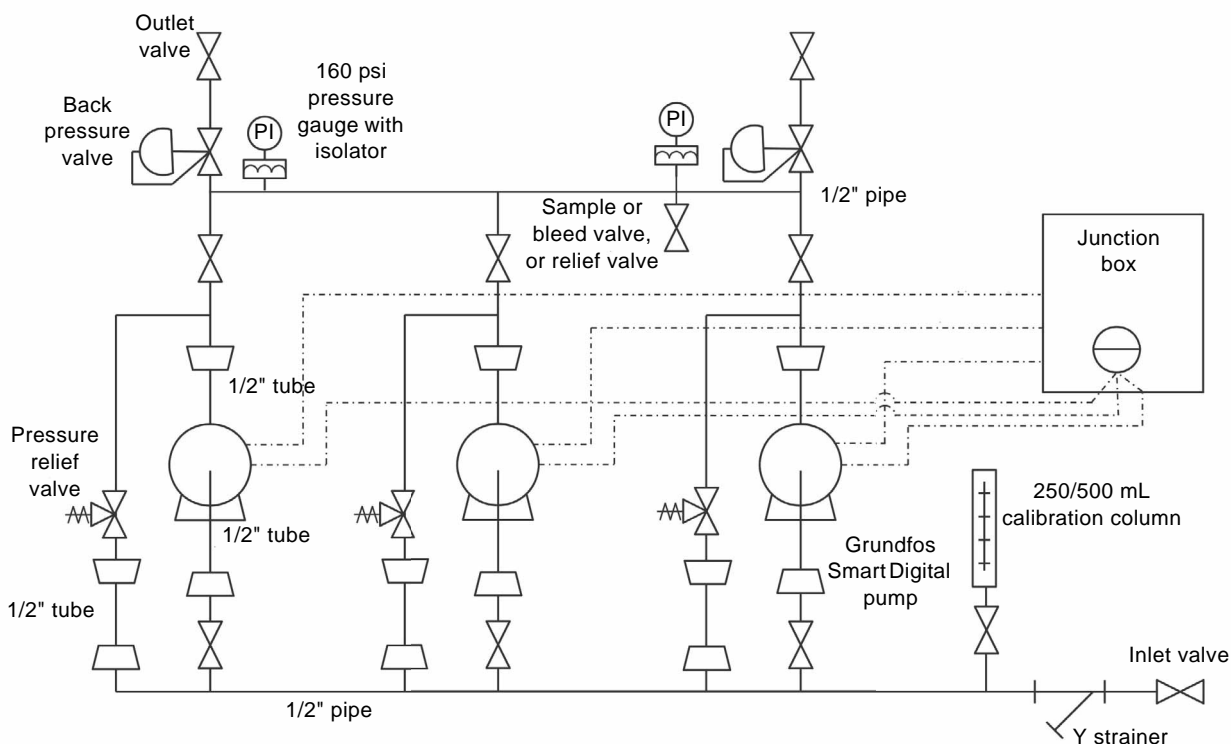

TM06 6243 0216

Fig. 5 Triplex DSS with junction box, see pos. 18 in fig. 2

## 5. Technical data

The values stated in the technical data of the components must be observed.

**Caution**

For the entire system, the value of the component with the most limited value applies.

**Caution**

The dosing medium must be in liquid state. Observe the freezing point of your dosing medium.

Refer to the installation and operating instructions of the dosing pump and characteristic of the dosing medium.

## 6. Transport and storage

**Caution**

Transport the DSS system carefully and only at temperatures above 41 °F (5 °C).  
Risk of breakage.

**Note**

The DSS system is tested for tightness in the factory. Some residual water may still be present in the fittings and pipes.

- Check the DSS system for transportation damage or missing parts.
- Store the DSS system in a sheltered place at temperatures between 41 and 113 °F (5 and 45 °C).



## 7. Installation

- During installation refer to Plant Engineering Drawings, Construction Drawings, Engineering Documentation, System - General Arrangement, P&ID and Electrical Drawings if included in the scope of delivery.

All DSS system pipes are supported within DSS. Make sure to adequately support all pipes outside DSS, including inlet, outlet, drain or vent pipes, to the site floor, wall or ceiling. Do not use the DSS pipes for support.

- Allow for clearance around the DSS system for regular maintenance to be safely carried out.
  - Allow provisions to drain the system pipes for maintenance and repair.
  - Depending on the vapor pressure of the dosing medium, you may need to mount the inlet line with a continuous upward slope from the supply tank to reduce gas locking, especially in volatile media.
1. Mount the DSS system to the wall if it is a wall-mounted system or on the floor if it is a floor-mounted system.
  2. Position DSS on an even, solid surface that is flat, hard, vibration free and leveled (i.e. a concrete floor or foundation).
  3. Install the on-site inlet, outlet and drain or vent pipes to the DSS termination point for the system inlet (1), outlet (16) and drain or vent pipe (13) in fig. 2. Make sure that the inlet conditions do not exceed the maximum suction lift capability of the dosing pump as described in the pump installation and operating instructions.
  4. Check that O-rings are installed in all unions.
  5. Check the tightness of all threaded connections.

**Caution** Pipes, components and equipment connections may become loose during transport or storage.

6. If required, install the pulsation dampers on DSS according to the pulsation damper connection instructions received with the DSS system.

**Note** The pulsation dampers may have been removed from DSS to prevent damage during transport.

7. If required, fit the calibration column into the 1/2" NPT connection on DSS in pos. 3 in fig. 2 on page 6.
8. A calibration column overflow accessory that can be fitted on top of the calibration column, is shipped separately. Install the calibration column overflow accessory with an appropriate length of 1/2" OD flexible tubing directed back to the dosing tank.

Keep the minimum diameter of the inlet and outlet lines. Too small diameters may cause damage to the DSS system and the dosing pump.

Depending on the viscosity and density of the dosing medium, the number of valves and fittings, and the length of the pipes, you may have to increase the pipe diameter.

The diameter and length of the outlet and inlet pipe or tube must be dimensioned in such a way that pressure peaks do not exceed the pressure limit during the dosing stroke and the minimum pressure does not fall below the vapor pressure of the dosing medium during the suction stroke.

### Caution



### Warning

Make sure that the room where the DSS system is installed has sufficient ventilation.



### Warning

Protect the DSS system against unauthorized access.

### Caution

The dosing medium must be in liquid state. Observe the freezing point of your dosing medium.

### Note

Keep the DSS system freely accessible for operation and maintenance.

Provide sufficient lighting.

### 7.1 Electrical connection

### Warning

The electrical work must be carried out by an authorized individual. Read manuals for all electrical components supplied with the DSS system or supplied separately. Make sure that the system is suitable for the power supply to which it is to be connected. The power supply, equipment and components (if included in the scope of delivery) must be installed, connected and tested by an authorized electrician in accordance with local codes and regulations and any wiring drawings supplied.



- DSS systems installed outdoors must be sheltered to allow trouble-free operation.
  - Exceptions are DSS systems equipped with an IP65 outdoor cabinet with integrated heating.

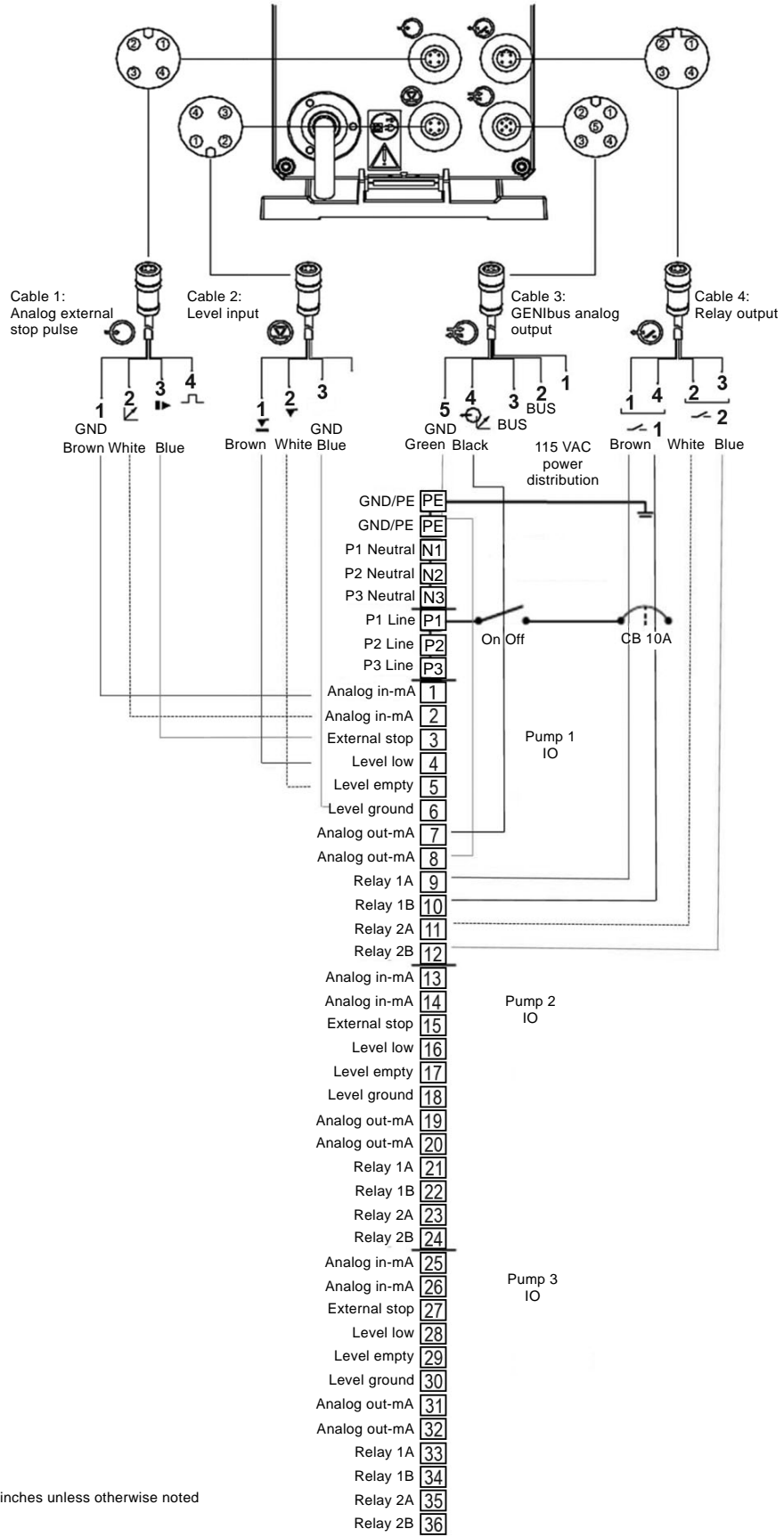

Not to scale  
 Dimensions are in inches unless otherwise noted

Fig. 6 Junction box wiring diagram

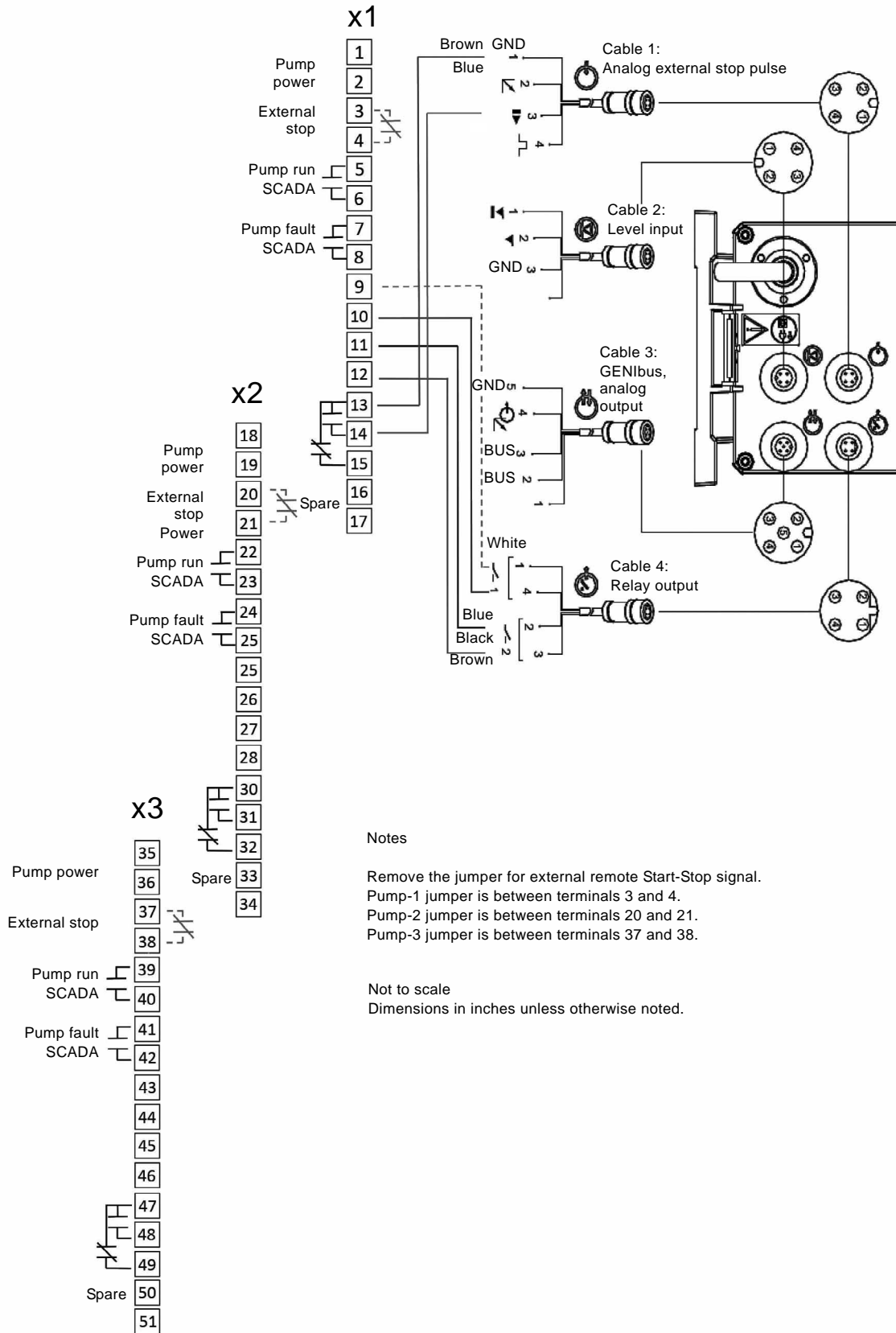

Fig. 7 Hand-Off-Auto control panel (HOA) wiring diagram

## 8. Startup



### Warning

Some chemicals react with water, which can lead to explosions. If the dosing medium can react with water, the DSS system must be flushed with a medium compatible with both water and the dosing medium first, to remove remaining water in the DSS system.

Prior to startup, flush all tanks and pipes.

### Caution

An initial test can be made with water if the dosing medium is compatible with water.

### Note

The DSS system is tested for tightness in the factory. Some residual water may still be present in the fittings and pipes.

1. Retighten all threaded joints.
2. Check the tightness of the entire DSS system and all pipes.
3. Check the electrical wiring and the power supply.
4. For dosing pumps with three-phase motors, additionally check the direction of rotation and the setting of the motor protection.
5. Install the inlet line with foot valve in the dosing tank.
  - Install the inlet line with a continuous upward slope towards the dosing pump.
6. Open the isolating valves for the dosing pump.
7. Vent the pump.
 

For details on venting the dosing pump, see installation and operating instructions for the dosing pump.

Optional procedure for venting a dosing pump via the sample or bleed valve:

  - Add a hose to the sample or bleed valve that directs the medium to a drain or back to the dosing tank.
  - Open the sample or bleed valve (13). See fig 2.
  - Start the pump and continue pumping until medium flows out of the sample or bleed valve.
  - Stop the pump and close the sample or bleed valve. The hose can either be removed or stay.
8. Check the proper interaction of all electronic signal accessories such as leakage detection, level switch, alarm relay, with the controller of the installation.

### 8.1 Calibration

Calibration must be done with the dosing medium. For details on calibration, see installation and operating instructions of the dosing pump.

## 9. Operation

In normal operation, the DSS system operates independently.

- Do not close the isolating valves on the outlet side of the pump during normal operation.
  - Otherwise the pressure relief valve (7 or 11) will open. See fig. 2
- Keep all isolating valves closed that are not in the line between the dosing medium inlet and the injection point, e.g. valve (3) of the calibration column; the inlet isolating valve (5 or 9) and outlet isolating valve (8 or 12) of the dosing pumps; and sample or bleed valve (13). The operator decides which pump is the duty pump and which is the standby pump. See fig. 2.
- Do not close or block the vent hole of the dosing tank.
- Do not contaminate the dosing tank.

## 10. Maintenance

### 10.1 Safety instructions

#### Warning

Cleaning and maintenance must only be carried out by authorized and qualified staff.



Wear the stipulated personal protective equipment (protective clothing, goggles, respirator etc.) when handling chemicals.

Observe the chemicals manufacturer's safety data sheets and safety instructions of the chemicals used.

#### Warning

Shut down the entire installation before starting any work on the system components and lines.



Before starting maintenance work, disconnect the DSS system from the power supply.

Before starting maintenance work, depressurize the outlet line.

Drain and flush dosing head, valves and pipes.

#### Warning

Safety devices, which have been deactivated during maintenance, must be activated again immediately after maintenance.



### Note

Store important spare parts close to the DSS system.

## 10.2 Maintenance intervals

### 10.2.1 Daily checks

- Inspect the tightness visually.

### 10.2.2 Regular checks

Carry out regular checks weekly or monthly, depending on the type of dosing pump and dosing medium. See the installation and operating instructions of the dosing pump and characteristic of the dosing medium.

- Check the dosing performance.
- Check the strainer
  - clean the strainer, if necessary.
- Maintain the dosing pump
  - see installation and operating instructions of the dosing pump.
- Maintain the pressure loading valve
  - see installation and operating instructions of the pressure loading valve.
- Check all accessories such as pulsation dampers and level switches to ensure they are functioning properly.

### 10.2.3 Annual checks

- Check the entire installation
  - replace gaskets, O-rings, diaphragms and other wear parts, if necessary.

**Note**

After maintenance, check the proper functioning and tightness of the entire installation.

## 11. Long-term shutdown

**Warning**

Some chemicals react with water, which can lead to explosions. If the dosing medium can react with water, the DSS system must be flushed with a medium compatible with the dosing medium.

1. Flush the dosing tank, lines, pipes, connections and pumps.
  - The flushing can be done with water if the dosing medium is compatible with water.
  - In case of danger of frost, remove remaining medium from tanks, lines and connections with compressed air.
2. Disconnect the DSS system from the power supply.

## 12. Disposal

This product or parts of it must be disposed of in an environmentally sound way. Use appropriate waste collection services. If this is not possible, contact the nearest Grundfos company or service workshop.

---

Subject to alterations.



**GRUNDFOS Kansas City**

17100 West 118th Terrace  
Olathe, Kansas 66061  
Phone: (913) 227-3400  
Fax: (913) 227-3500

[www.grundfos.us](http://www.grundfos.us)

**GRUNDFOS Canada**

2941 Brighton Road  
Oakville, Ontario L6H 6C9 Canada  
Phone: +1-905 829 9533  
Telefax: +1-905 829 9512

[www.grundfos.ca](http://www.grundfos.ca)

**GRUNDFOS México**

Boulevard TLC No. 15  
Parque Industrial Stiva Aeropuerto  
C.P. 66600 Apodaca, N.L. México  
Phone: 011-52-81-8144 4000  
Fax: 011-52-81-8144 4010

[www.grundfos.mx](http://www.grundfos.mx)

<b>99000331</b> 1016
ECM: 1194718

The name Grundfos, the Grundfos logo, and be think innovate are registered trademarks owned by Grundfos Holding A/S or Grundfos A/S, Denmark. All rights reserved worldwide. © Copyright Grundfos Holding A/S