

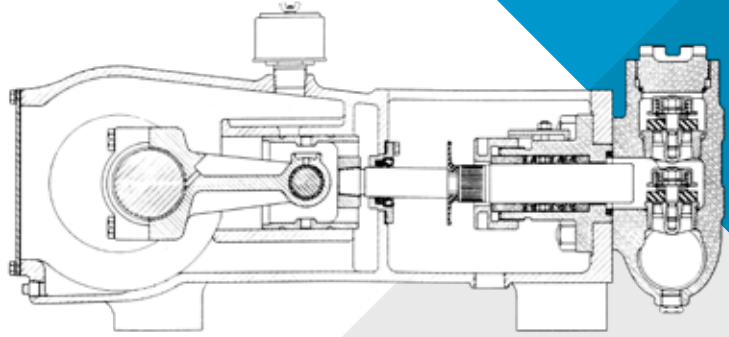

MA-60M/60H

TRIPLEX PLUNGER PUMP



No. of plungers	3
Maximum rated speed	500 rpm
Stroke length.....	3.00 in. 76.2 mm
Maximum rated power.....	60.0 HP 44.7 KW
Maximum rod load	4752 lb. 21.09 kN
Weight	945 lbs.

ENGLISH UNITS (MA-60M)

PLUNGER SIZE IN.	STUFFING BOX BORE IN.	MAX PSI	*GALLON PER/REV.	300 RPM US GPM	350 RPM US GPM	400 RPM US GPM	450 RPM US GPM	500 RPM US GPM
2.500	3.250	968	0.191	57.4	66.9	76.5	86.1	95.6
2.375	3.250	1073	0.173	51.8	60.4	69	77.7	86.3
2.250	3.250	1195	0.155	46.5	54.2	62	69.7	77.5
2.125	2.875	1340	0.138	41.5	48.4	55.3	62.2	69.1
2.000	2.875	1513	0.122	36.7	42.8	49	55.1	61.2
1.875	2.875	1721	0.108	32.3	37.7	43	48.4	53.8
1.750	2.875	1976	0.094	28.1	32.8	37.5	42.2	46.9
1.625	2.500	2291	0.081	24.2	28.3	32.3	36.4	40.4
1.500	2.500	2689	0.069	20.7	24.1	27.5	31	34.4
1.375	2.250	3200	0.058	17.4	20.2	23.1	26	28.9
HP REQUIRED @ RPM**				36	42	48	54	60

METRIC UNITS (MA-60M)

PLUNGER SIZE MM	STUFFING BOX BORE MM	MAX PRESS. BAR	*LITER PER/REV.	300 RPM LPM	350 RPM LPM	400 RPM LPM	450 RPM LPM	500 RPM LPM
63.5	82.6	66.7	0.724	217.2	253.4	289.6	325.8	362
60.3	82.6	74	0.653	196	228.7	261.4	294	326.7
57.2	82.6	82.4	0.586	175.9	205.2	234.6	263.9	293.2
54	73	92.4	0.523	156.9	183.1	209.2	235.4	261.6
50.8	73	104.3	0.463	139	162.2	185.3	208.5	231.7
47.6	73	118.7	0.407	122.2	142.6	162.9	183.3	203.7
44.5	73	136.2	0.355	106.4	124.1	141.9	159.6	177.3
41.3	63.5	158	0.306	91.8	107.1	122.4	137.7	152.9
38.1	63.5	185.4	0.261	78.2	91.3	104.3	117.4	130.4
34.9	57.2	220.6	0.219	65.8	76.7	87.7	98.6	109.6
KW REQUIRED @ RPM**				26.8	31.3	35.8	40.3	44.7

*Displacement based on 100% Volumetric Efficiency

**Power based on 90% Mechanical Efficiency

$$IHP = \frac{USGPM \times (\text{Discharge psig} - 1/2 \text{ Suction psig})}{1542}$$

$$IKW = \frac{M^3/HR \times (\text{Discharge Bar} - 1/2 \text{ Suction Bar})}{32.4}$$

$$PUMP \text{ RPM} = \frac{USGPM \text{ Desired}}{USG \text{ per Revolution of Selected Plunger}}$$

$$PUMP \text{ RPM} = \frac{M^3/HR \text{ Desired}}{M^3 \text{ per Revolution of Selected Plunger}}$$

ENGLISH UNITS (MA-60H)

PLUNGER SIZE IN.	STUFFING BOX BORE IN.	MAX PSI	* GALLON PER/REV.	100 RPM US GPM	200 RPM US GPM	300 RPM US GPM	400 RPM US GPM	500 RPM US GPM
1.375	2.250	3200	0.0579	5.8	11.6	17.4	23.1	28.9
1.250	2.250	3872	0.0478	4.8	9.6	14.3	19.1	23.9
1.125	1.750	4780	0.0387	3.9	7.7	11.6	15.5	19.4
1.000	1.750	5000	0.0306	3.1	6.1	9.2	12.2	15.3
HP REQUIRED @ RPM**				12.0	24.0	36.0	48.0	60.0

METRIC UNITS (MA-60H)

PLUNGER SIZE MM.	STUFFING BOX BORE MM.	MAX PRESS. BAR	* LITER PER/REV.	100 RPM LPM	200 RPM LPM	300 RPM LPM	400 RPM LPM	500 RPM LPM
34.9	57.2	220.6	0.2192	21.9	43.8	65.8	87.7	109.6
31.8	57.2	267.0	0.1809	18.1	36.2	54.3	72.4	90.5
28.6	44.5	329.6	0.1465	14.7	29.3	44.0	58.6	73.3
25.4	44.5	344.8	0.1158	11.6	23.2	34.7	46.3	57.9
KW REQUIRED @ RPM**				8.9	17.9	26.8	35.8	44.7

*Displacement based on 100% Volumetric Efficiency

$$IHP = \frac{USGPM \times (\text{Discharge psig} - 1/2 \text{ Suction psig})}{1542}$$

$$PUMP \text{ RPM} = \frac{USGPM \text{ Desired}}{USG \text{ per Revolution of Selected Plunger}}$$

**Power based on 90% Mechanical Efficiency

$$IKW = \frac{M^3/HR \times (\text{Discharge Bar} - 1/2 \text{ Suction Bar})}{32.4}$$

$$PUMP \text{ RPM} = \frac{M^3/HR \text{ Desired}}{M^3 \text{ per Revolution of Selected Plunger}}$$

MA-60M Triplex Pump

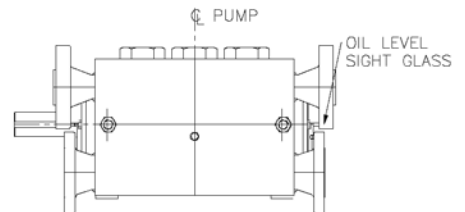
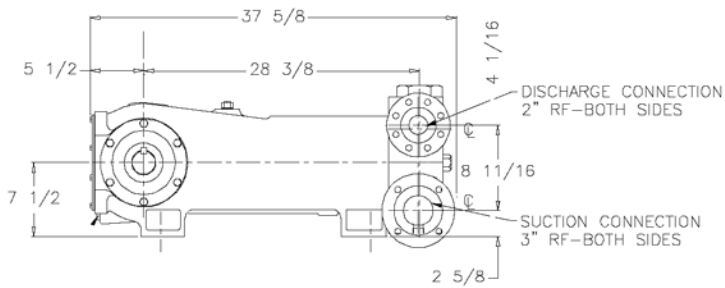
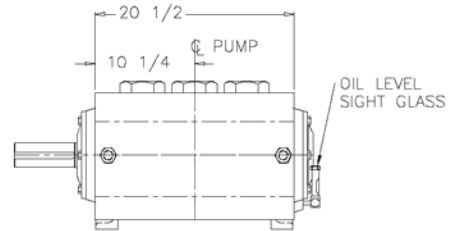
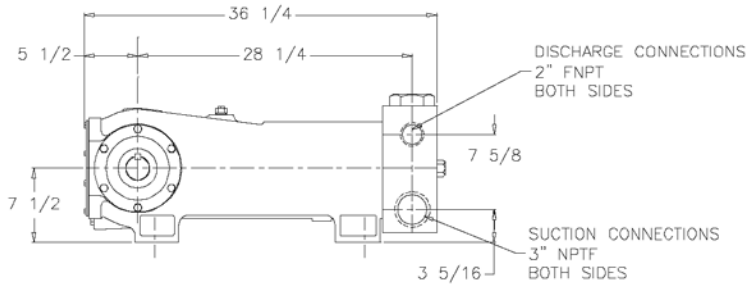
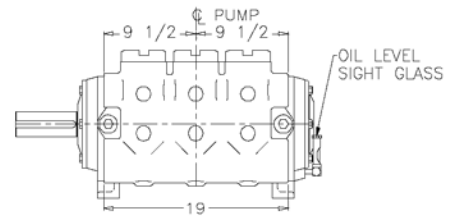
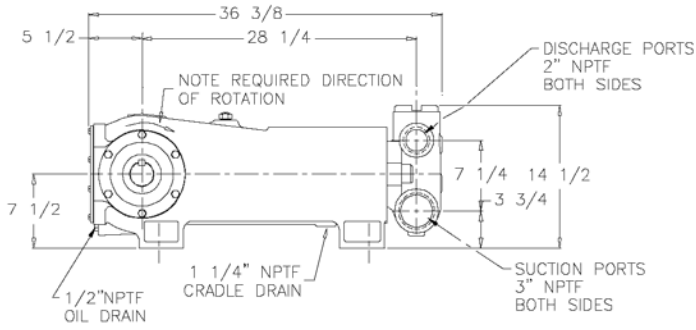
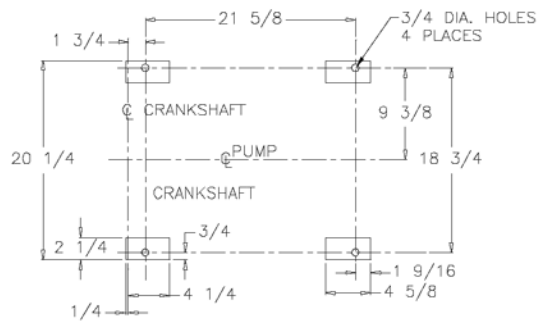
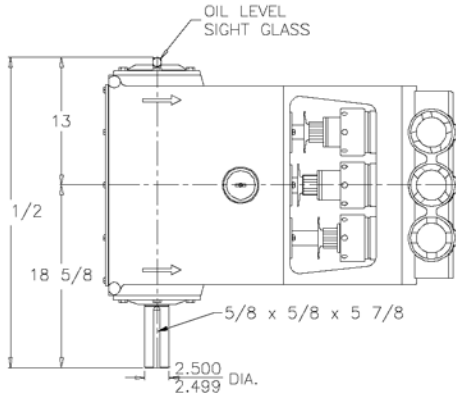

MA-60M Triplex Pump

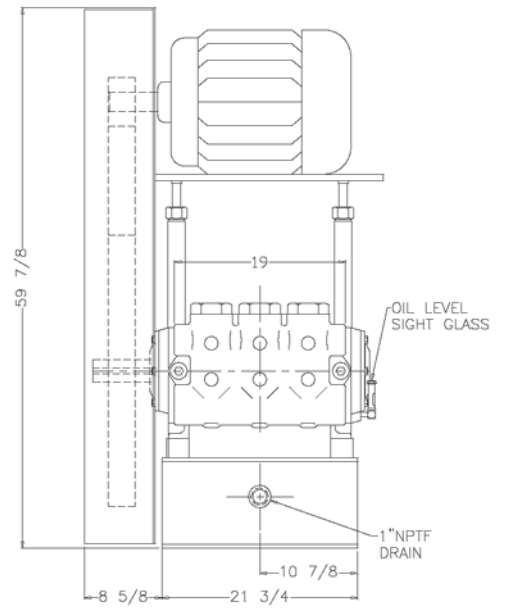
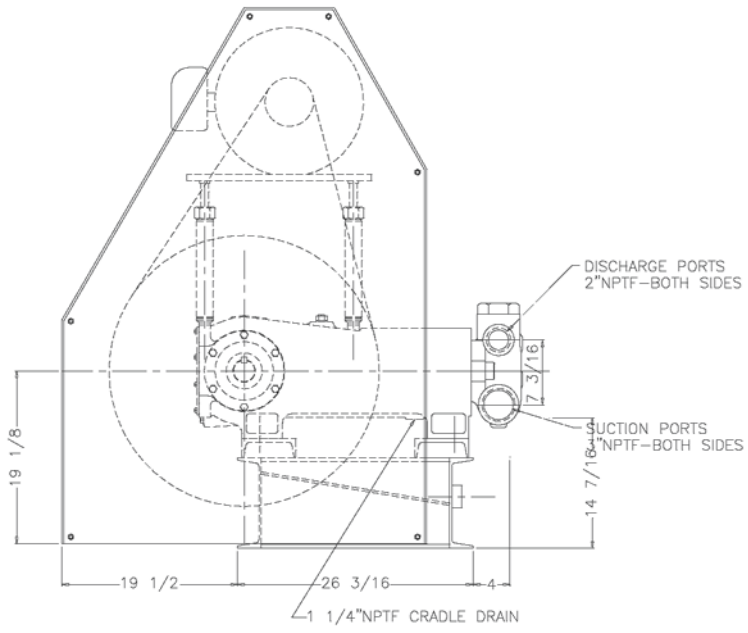

MA-60H Triplex Pump

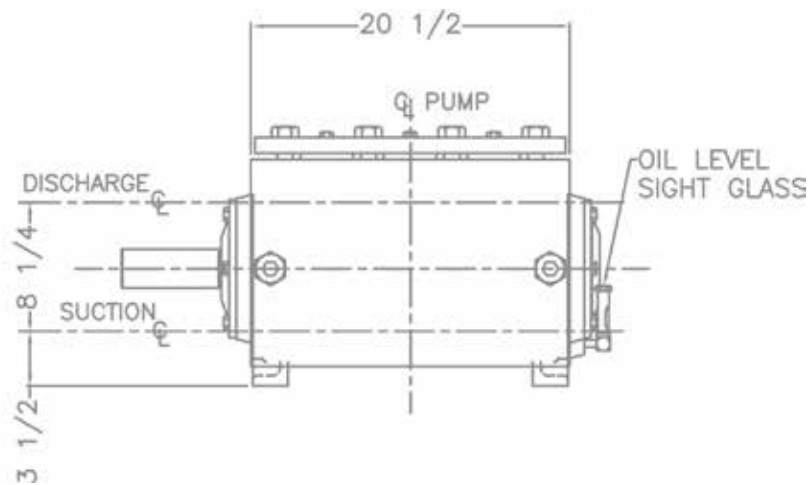
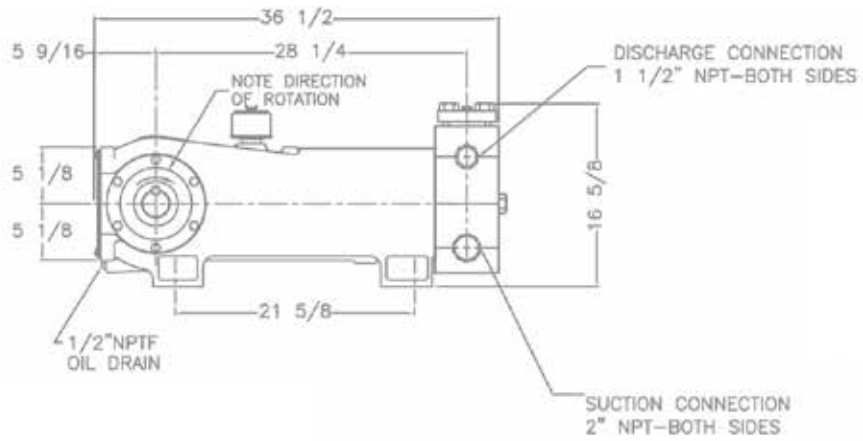
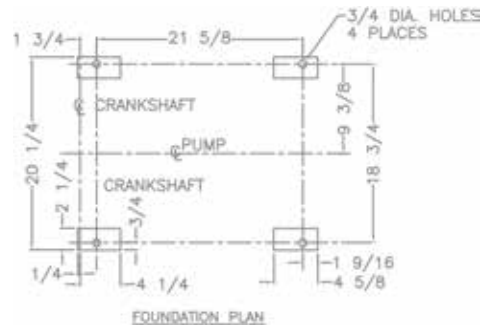
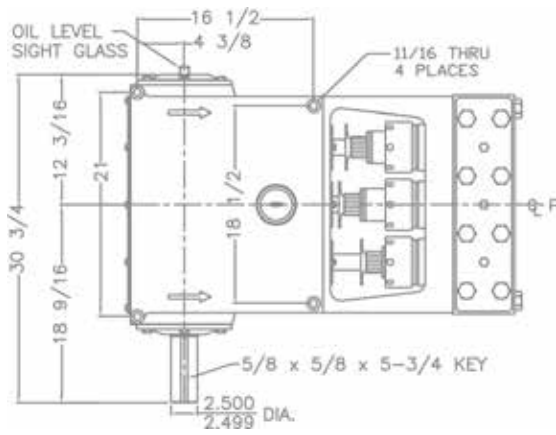

ENGINEERING DATA

MA-60M /60H Triplex Pump

POWER END ENGINEERING DATA

Max. Input Power @ Speed.....	60 HP @ 500 rpm
Rated Continuous Plunger Load	4,752 lb.
Max. Rated Continuous Speed	500 rpm
Normal Continuous Speed Range	150 to 450 rpm
Minimum Speed	100 rpm
Oil Capacity	9 U.S. Qrts
Power End Oiling System	Splash
Power Frame, One-Piece	Class 30 Cast Iron
Crosshead, Full Cylindrical	Cast Iron
Crosshead, Dia. x Length	4 3/4 x 5 in.
Crankshaft	Ductile Iron
Crankshaft Diameters:	
At Tapered Roller Bearings	2 5/8 in.
At Crankpin Bearings, Dia. x Length	3 1/2 x 3 in.
Crosshead (Wrist) Pin, Case-Hardened and Ground	AlSI 8620
Wrist Pin Bushing, SAE 660, dia. x width	1 1/2" x 2.25 in.®
Main Bearings, Tapered Roller	Timken
Crankpin Bearings, Precision Automotive	Steel Backed, Babbitt-Lined
Extension (Pony) Rod	17-4 PH S.S.
Connecting Rod, Automotive Type	Ductile Iron
Average Crosshead Speed @ 500 rpm	250 fpm
Minimum Life Expectancy, Main Bearings, L ₁₀	60,000+ hrs.

LIQUID END ENGINEERING DATA

Max. Continuous Working Pressure 60M	3,200 psi
Max. Continuous Working Pressure 60H	5,000 psi
Hydrostatic Test 60M.....	4,800 psi
Hydrostatic Test 60H.....	7,500 psi
Available Liquid End Materials, A.S.T.M.	
Nickel Aluminum Bronze Casting 60M.....	B148-C955
Carbon Steel Block 60M, 60H.....	Various Grades
Stainless Steel Block 60M, 60H.....	Various Grades
Ductile Iron Casting 60M	A536 80-55-06
Plunger Type (Chromium Oxide-Coated)	316 S.ST. (Other types available include Tungsten Carbide, Ceramic)
Stuffing Boxes, Field-Removable and Replaceable	Nickel Aluminum Bronze, Carbon Steel, Stainless Steel
Gland, Stuffing Box	Nickel Aluminum Bronze, Carbon Steel, Stainless Steel
Packing Types Available:	
Gland-Loaded, Non-Adjustable	Style 0838
Spring-loaded, cup-type	Style 120X
Spring-loaded, Braided PTFE Coating & Aramid Fiber	Style 0140, 0141, 8921K
Valve Cover and Cyl. Head Plugs	Same as Fluid End
Seals, Stuffing Boxes, Valve Covers, Cyl. Heads	Nitrile or PTFE
Available Valve Types:	
Standard Disc Type, Acetal Resin (60M)	Acetal
Optional Disc Type, Hardened and Lapped Stainless Steel	17-4PH S.S.®
Valve Spring Material	Inconel®
Plate (Disc) Valves, (Acetal or S.ST.) 60M	2.4 sq. in.
Plate (Disc) Valves, (Acetal or S.ST.) 60H	2.3 sq. in.
Abrasion Resistant Wing Guided Valves 60M	2.4 sq. in.
Abrasion Resistant Wing Guided Valves 60H	1.07 sq. in.
Valve Seat, Liquid Passage Area	
Avg. Liquid Velocity with 2 1/2" plungers @ 500 rpm:	
thru Suction Manifold	
60M	4.3 fps
60H	2.95 fps
thru Discharge Manifold	10.4 fps
60M	9.8 fps
60H	5.2 fps

All drawings and specifications subject to change without notice.

THIS PAGE IS LEFT BLANK INTENTIONALLY



1101 MYERS PARKWAY,
ASHLAND, OHIO 44805
WWW.FEMYERS.COM

490 PINEBUSH ROAD, UNIT 4,
CAMBRIDGE, ONTARIO N1T 0A5
WWW.FEMYERS.COM

Inconel® is a registered trademark of the Special Metals family of companies.
Timken® is a registered trademark of The Timken Company.
Myers® is a registered trademark of Pentair.

For a detailed list of where Pentair trademarks are registered, please visit www.pentair.com/en/registrations.html. Pentair trademarks and logos are owned by Pentair plc or its affiliates. Third party registered and unregistered trademarks and logos are the property of their respective owners because we are continuously improving our products and services. Pentair reserves the right to change specifications without prior notice. Pentair is an equal opportunity employer.
MA1012 (05/20/20) ©2020 Pentair. All Rights Reserved.