

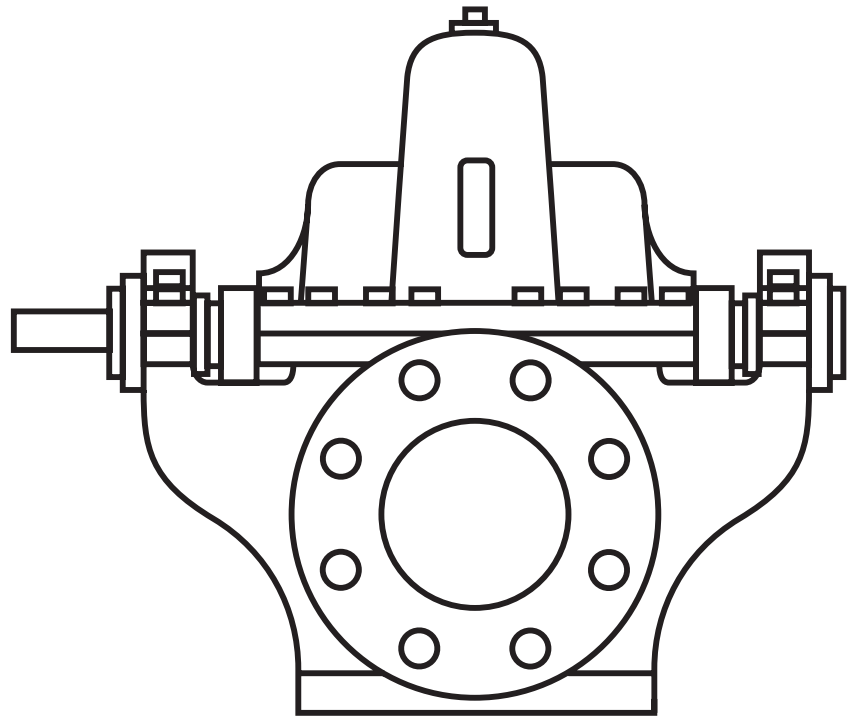

FAIRBANKS NIJHUIS®



1800, 1900 MODELS

VERTICAL AND HORIZONTAL SPLIT CASE FIRE PUMPS

REPAIR PARTS INDEX

NOTE! Read and understand the pump and driver instructions before attempting to install, disassemble or repair the pump.

1800 HORIZONTAL SPLIT CASE PIECE NUMBERS

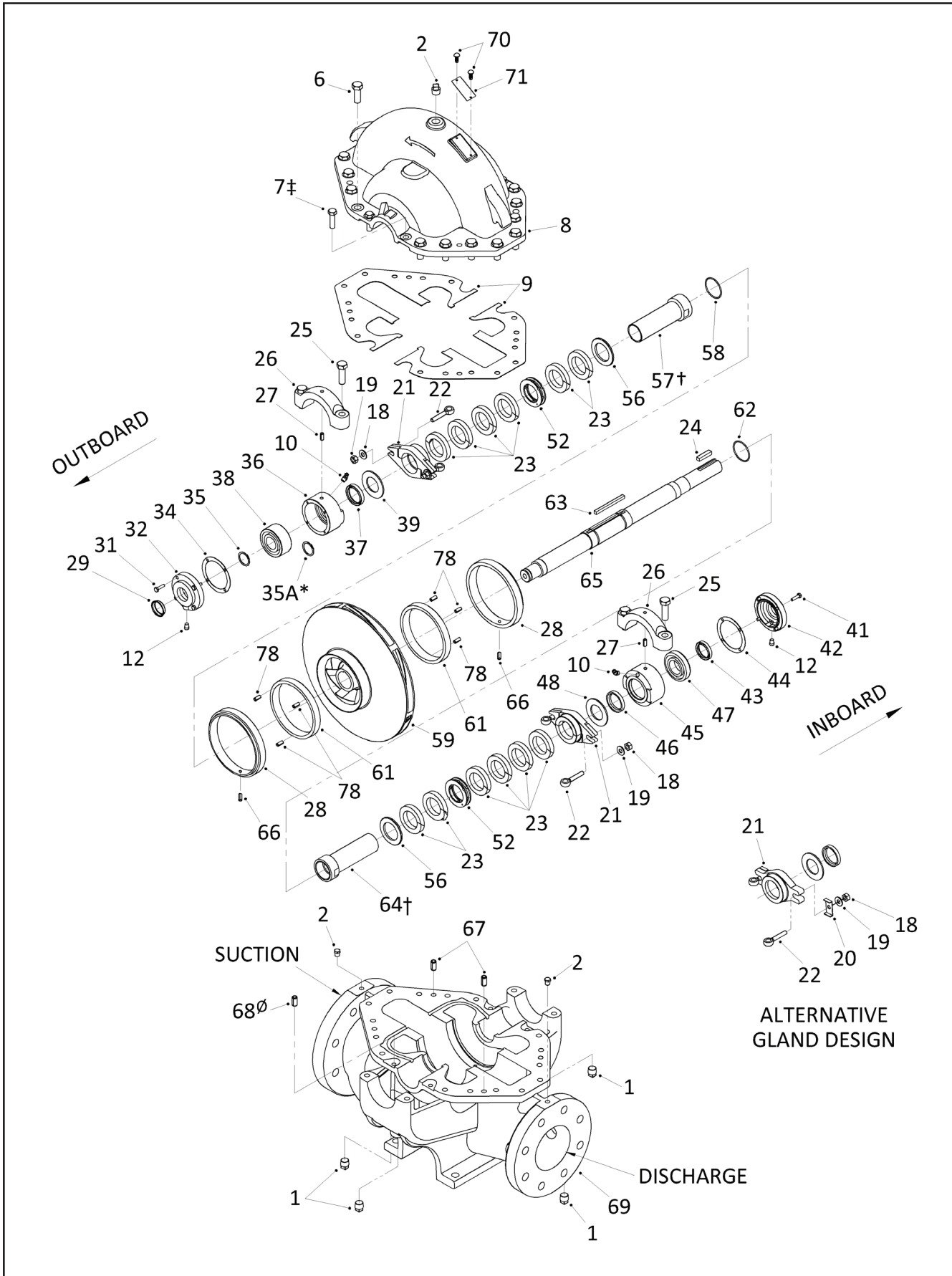

1800 VERTICAL SPLIT CASE PIECE NUMBERS

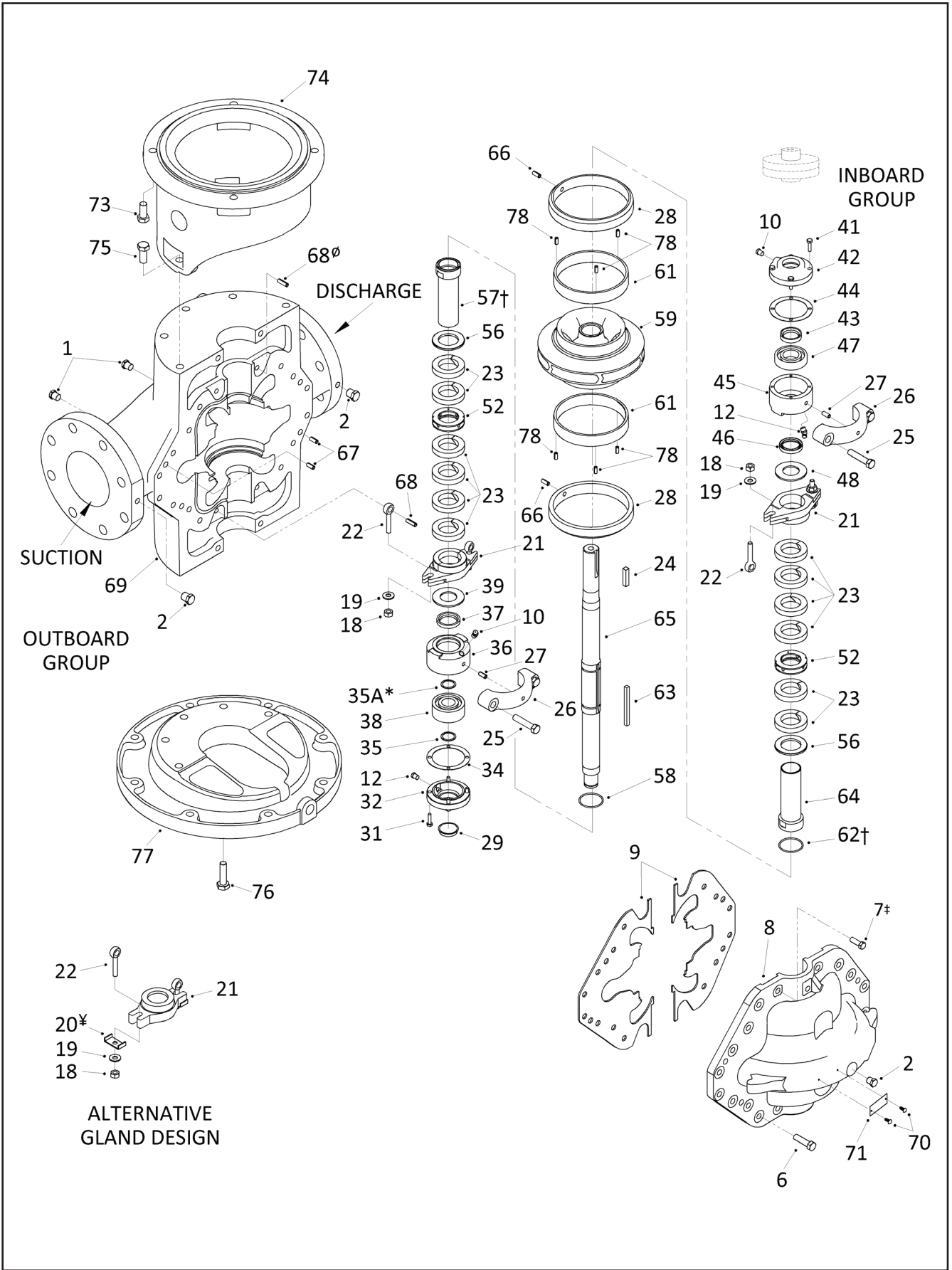

MODEL 1900* PIECE NUMBERS

*Use for all 1900 series except 5"1924F and 6"1924F

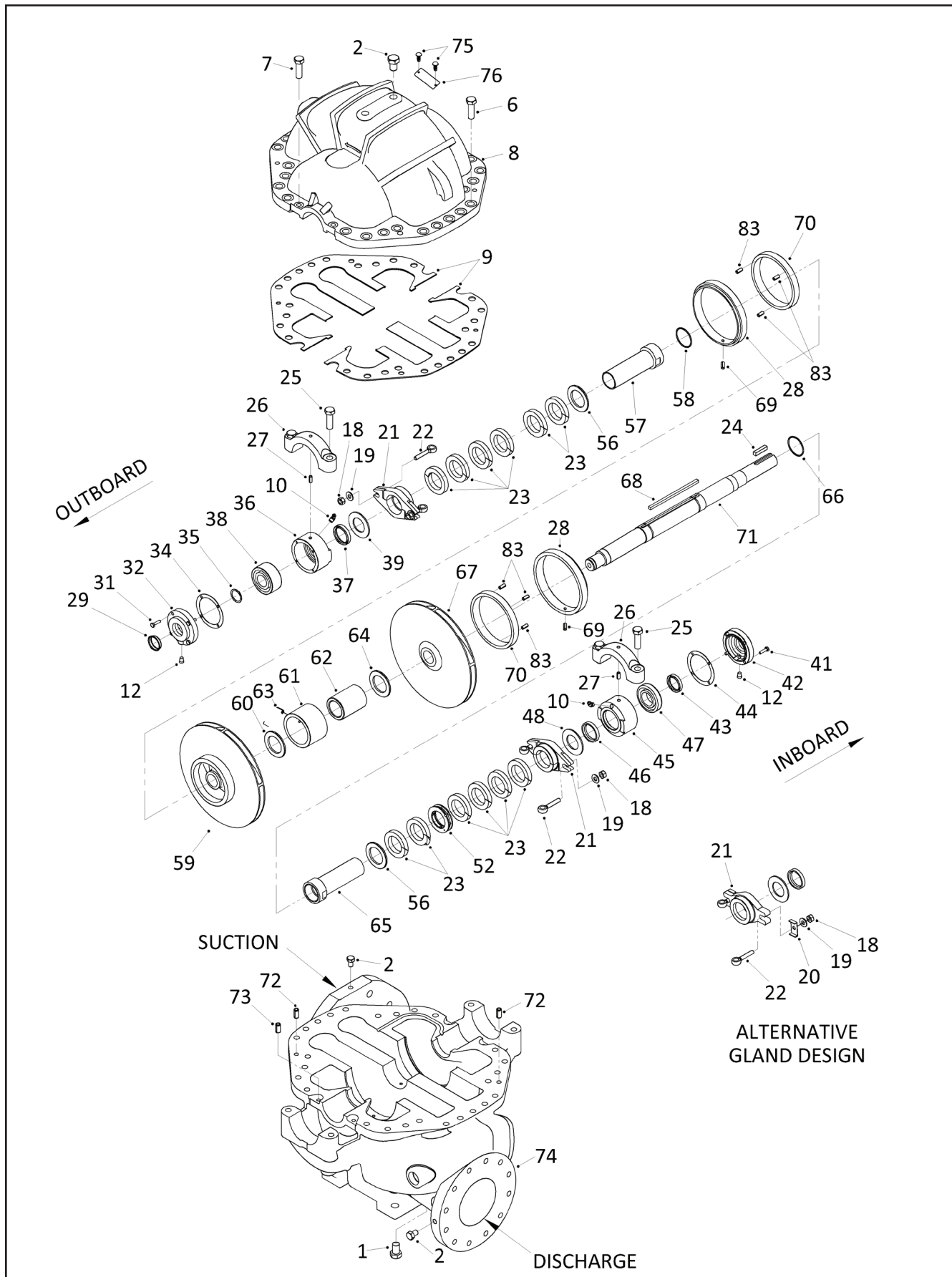

MODEL 1900** PIECE NUMBERS

**Use for 5"1924F & 6"1924F

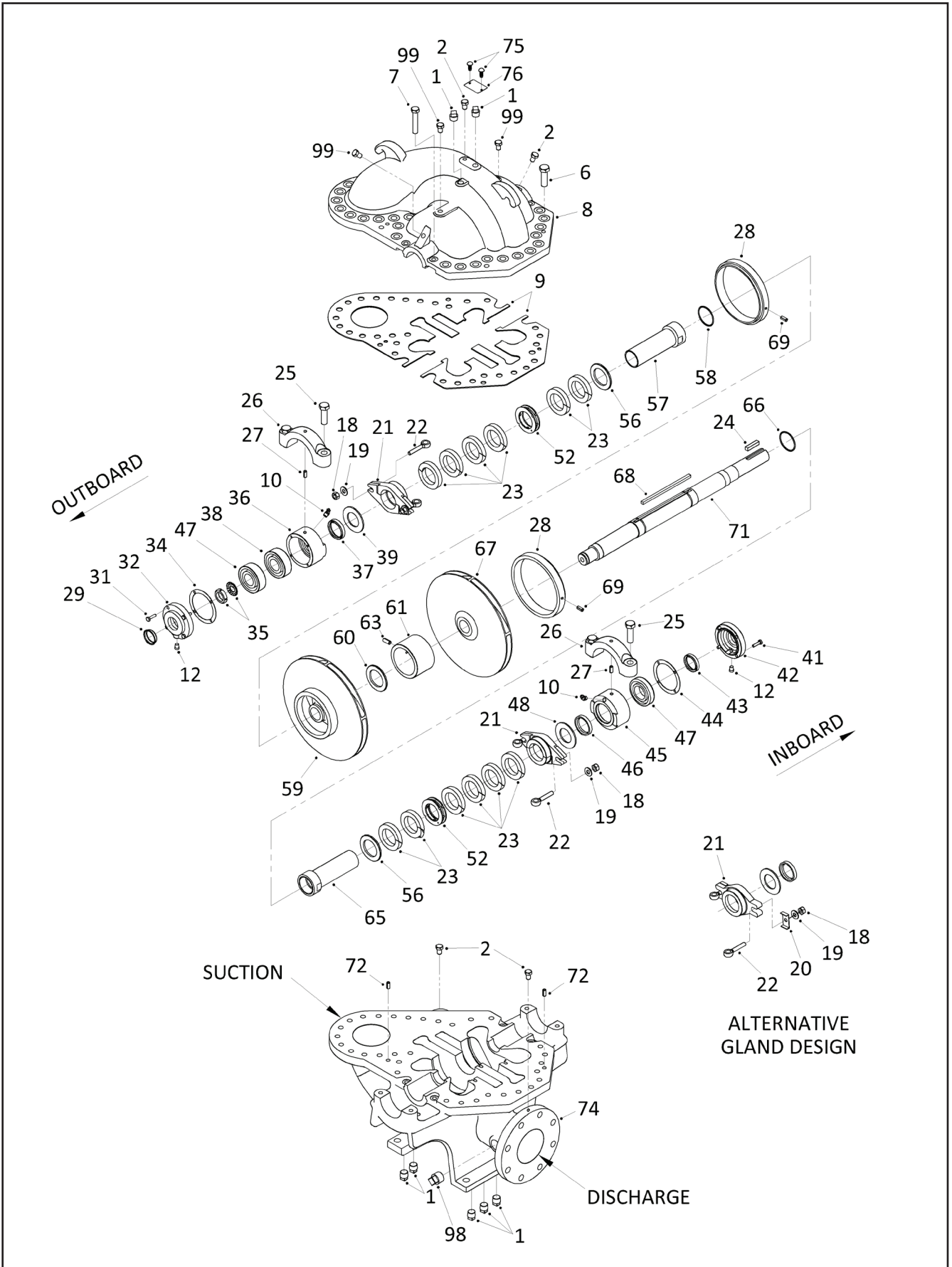

FAIRBANKS NIJHUIS®
1800, 1900 MODELS

1800 HORIZONTAL SPLIT CASE PARTS LIST

POWER SERIES				2		3			
ITEM NUMBER	COMPONENT TYPE	OTHER	QTY.	2.5"1823BF	3"1824F	4"1823AF	4"1823CF	4"1823DF	4"1824F
8 & 69	Casing Assy	125# x 125#	1	179-2296-010	179-1584-010	179-1585-010	179-1585-010	179-2515-010	179-1586-010
8 & 69	Casing Assy	125# x 250#	1	179-2349-010	179-2105-010	179-2107-010	179-2107-010	179-2516-010	179-2111-010
8 & 69	Casing Assy	250# x 250#	1	179-2304-010	179-1619-010	179-1620-010	179-1620-010	179-2517-010	179-1621-010
59	Impeller		1	443-2295-225	443-2266-225	443-2112-208	443-0147-208	443-2984-225	443-2115-208
65	Shaft		1	728-0946-063	728-0946-063	728-0947-063	728-0947-063	728-0947-063	728-0947-063
65	Shaft (optional)		1	728-0946-109	728-0946-109	728-0947-109	728-0947-109	728-0947-109	728-0947-109
64	Shaft Sleeve		2	756-0642-644	756-0642-644	756-0643-644	756-0643-644	756-0643-644	756-0643-644
66	Case Wear Ring		2	676-1745-208	676-1746-208	676-1720-208	676-1747-208	676-2136-208	676-1747-208
9	Casing Gasket		1	364-1263-598	364-1265-598	364-0099-598	364-0099-598	364-2165-598	364-1268-598
21	Gland		2	372-0602-104	372-0602-104	372-0603-104	372-0603-104	372-0608-104	372-0603-104
38	Bearing		1	068-0454-647	068-0454-647	068-0455-647	068-0455-647	068-0455-647	068-0455-647
47	Bearing		1	068-1907-647	068-1907-647	068-1908-647	068-1908-647	068-1908-647	068-1908-647
52	Lantern Ring*		2	676-1698-512	676-1698-512	676-1699-512	676-1699-512	676-1699-512	676-1699-512
23	Packing			564-0151-802	564-0151-802	564-0175-816	564-0175-816	564-0175-816	564-0175-816
	Qty Required*			12	12	10	10	10	10
	Repair Kit			476-0630-644	476-0630-644	476-0631-644	476-0631-644	476-0631-644	476-0631-644
	Overhaul Kit			476-0451-483	476-0451-483	476-0451-483	476-0372-483	476-1095-483	476-0372-483
	Rotating Assy			700-0084-483	700-0006-483	700-0009-483	700-0023-483	700-0742-483	700-0012-483

POWER SERIES				4					
ITEM NUMBER	COMPONENT TYPE	OTHER	QTY.	5"1822BF	5"1822CF	5"1822DF	5"1823F	5"1823AF	5"1824F
8 & 69	Casing Assy	125# x 125#	1	179-1588-010	179-1588-010	179-1587-010	179-1590-055	179-1590-055	179-1591-010
8 & 69	Casing Assy	125# x 250#	1	179-2248-010	179-2248-010	179-2250-010	179-2113-055	179-2113-055	179-2115-010
8 & 69	Casing Assy	250# x 250#	1	179-1623-010	179-1623-010	179-1622-010	179-1625-055	179-1625-055	179-1626-010
59	Impeller		1	443-0656-208	443-2300-225	443-2122-208	443-2117-208	443-3323-104	443-2118-225
65	Shaft		1	728-0948-063	728-0948-063	728-0948-063	728-0948-063	728-0948-063	728-0948-063
65	Shaft (optional)		1	728-0948-109	728-0948-109	728-0948-109	728-0948-109	728-0948-109	728-0948-109
64	Shaft Sleeve		2	756-0644-644	756-0644-644	756-0644-644	756-0644-644	756-0644-644	756-0644-644
66	Case Wear Ring		2	676-1748-208	676-1748-208	676-1721-208	676-1748-208	676-1748-208	676-1748-208
9	Casing Gasket		1	364-0809-598	364-0809-598	364-1269-598	364-1270-598	364-1270-598	364-1270-598
21	Gland		2	372-0604-104	372-0604-104	372-0604-104	372-0604-104	372-0604-104	372-0604-104
38	Bearing		1	068-0456-647	068-0456-647	068-0456-647	068-0456-647	068-0456-647	068-0456-647
47	Bearing		1	068-0359-647	068-0359-647	068-0359-647	068-1909-647	068-1909-647	068-1909-647
52	Lantern Ring*		2	676-1700-512	676-1700-512	676-1700-512	676-1700-512	676-1700-512	676-1700-512
23	Packing			564-0176-816	564-0176-816	564-0176-816	564-0176-816	564-0176-816	564-0176-816
	Qty Required*			12	12	12	12	12	12
	Repair Kit			476-0632-644	476-0632-644	476-0632-644	476-0632-644	476-0632-644	476-0632-644
	Overhaul Kit			476-0373-483	476-0373-483	476-0373-483	476-0373-483	476-0373-483	476-0373-483
	Rotating Assy			700-0101-483	700-0484-483	700-0496-483	700-0014-483	700-0261-483	700-0015-483

POWER SERIES				4	4A	5			
ITEM NUMBER	COMPONENT TYPE	OTHER	QTY.	6"1822F	6"1822HHF	6"1823F	6"1823BF	6"1823CF	6"1824BF
8 & 69	Casing Assy	125# x 125#	1	179-1592-010		179-1593-010	179-1593-010	179-1593-010	179-1594-010
8 & 69	Casing Assy	125# x 250#	1	179-2117-010		179-2506-055	179-2119-010	179-2119-010	179-2253-010
8 & 69	Casing Assy	250# x 250#	1	179-1627-010		179-2507-055	179-1628-010	179-1628-010	179-1629-010
59	Impeller		1	443-2116-208		443-2990-208	443-2119-225	443-0649-208	443-0658-225
65	Shaft		1	728-0948-063		728-7304-063	728-0949-063	728-0949-063	728-0949-063
65	Shaft (optional)		1	728-0948-109		728-7304-109	728-0949-109	728-0949-109	728-0949-109
64	Shaft Sleeve		2	756-0644-644		756-0828-644	756-0645-644	756-0645-644	756-0645-644
66	Case Wear Ring		2	676-1748-208		676-2138-208	676-1750-208	676-1750-208	676-1989-208
9	Casing Gasket		1	364-1271-598		364-2166-598	364-1272-598	364-1272-598	364-0802-598
21	Gland		2	372-0604-104		372-0604-104	372-0605-104	372-0605-104	372-0605-104
38	Bearing		1	068-0456-647		068-0456-647	068-0458-647	068-0458-647	068-0458-647
47	Bearing		1	068-1909-647		068-1909-647	068-0160-647	068-0160-647	068-0160-647
52	Lantern Ring*		2	676-1700-512		676-1700-512	676-1701-512	676-1701-512	676-1701-512
23	Packing			564-0176-816		564-0176-816	564-0177-816	564-0177-816	564-0177-816
	Qty Required*			12		12	12	12	12
	Repair Kit			476-0632-644		476-0912-644	476-0633-644	476-0633-644	476-0633-644
	Overhaul Kit			476-0373-483		476-0917-483	476-0374-483	476-0374-483	476-0374-483
	Rotating Assy			700-0025-483		700-0745-483	700-0018-483	700-0250-483	700-0486-483

* Not all pump assemblies contain a lantern ring. When Lantern ring is present, subtract 2 pieces of packing.

1800 HORIZONTAL SPLIT CASE PARTS LIST

POWER SERIES				5				5A	6B
ITEM NUMBER	COMPONENT TYPE	OTHER	QTY.	6"1824CF	6"1825F	8"1822F	8"1824BF	6"1823HHF	8"1825F
8 & 69	Casing Assy	125# x 125#	1	179-1594-010	179-1595-010	179-1596-010	179-1598-010		179-2333-010
8 & 69	Casing Assy	125# x 250#	1	179-2253-010	179-2121-010	179-2123-010	179-2127-010	179-2500-055	179-2331-010
8 & 69	Casing Assy	250# x 250#	1	179-1629-010	179-1630-010	179-1631-010	179-1633-010	179-2501-055	179-2335-010
59	Impeller		1	443-2298-208	443-2120-225	443-2119-225	443-0476-208	443-2985-208	443-2432-208
65	Shaft		1	728-0949-063	728-0949-063	728-0949-063	728-0949-063	728-7302-063	728-0502-076
65	Shaft (optional)		1	728-0949-109	728-0949-109	728-0949-109	728-0949-109	728-7302-109	728-0502-116
64	Shaft Sleeve		2	756-0645-644	756-0645-644	756-0645-644	756-0645-644	756-0827-644	756-0646-644
66	Case Wear Ring		2	676-1750-208	676-1750-208	676-1750-208	676-0018-208	676-2137-208	676-2031-208
9	Casing Gasket		1	364-0802-598	364-1273-598	364-1274-598	364-1276-598	364-2161-598	364-2110-598
21	Gland		2	372-0605-104	372-0605-104	372-0605-104	372-0605-104	372-0605-104	372-0606-104
38	Bearing		1	068-0458-647	068-0458-647	068-0458-647	068-0458-647	068-0458-647	068-0362-647
47	Bearing		1	068-0160-647	068-0160-647	068-0160-647	068-0160-647	068-0160-647	068-1912-647
52	Lantern Ring*		2	676-1701-512	676-1701-512	676-1701-512	676-1701-512	676-1701-512	676-1462-512
23	Packing			564-0177-816	564-0177-816	564-0177-816	564-0177-816	564-0177-816	564-0179-802
	Qty Required*			12	12	12	12	12	12
	Repair Kit			476-0633-644	476-0633-644	476-0633-644	476-0633-644	476-0913-644	476-0634-644
	Overhaul Kit			476-0374-483	476-0374-483	476-0374-483	476-0374-483	476-0918-483	476-0375-483
	Rotating Assy			700-0487-483	700-0019-483	700-0027-483	700-0021-483	700-0743-483	700-0658-483

POWER SERIES				6B		7	7A		
ITEM NUMBER	COMPONENT TYPE	OTHER	QTY.	8"1825AF	10"1823CF	10"1824F	8"1826F	10"1824AF	10"1824DF
8 & 69	Casing Assy	125# x 125#	1	179-2461-010	179-1599-010	179-1600-010	179-2526-055	179-2297-010	179-2422-010
8 & 69	Casing Assy	125# x 250#	1	179-2462-010	179-2255-010	179-2271-010	179-2527-055	179-2348-010	179-2423-010
8 & 69	Casing Assy	250# x 250#	1	179-2463-010	179-1634-010	179-1635-010	179-2528-055	179-1636-010	179-2424-010
59	Impeller		1	443-2662-208	443-0841-208	443-0652-225	443-3149-208	443-2482-208	443-2986-225
65	Shaft		1	728-0502-076	728-0502-076	728-0502-076	728-0503-076	728-0503-076	728-7306-076
65	Shaft (optional)		1	728-0502-116	728-0502-116	728-0502-116	728-0503-116	728-0503-116	728-7306-116
64	Shaft Sleeve		2	756-0646-644	756-0646-644	756-0646-644	756-0647-644	756-0647-644	756-0774-644
66	Case Wear Ring		2	676-2014-208	676-1983-208	676-1984-208	676-7125-208	676-2056-208	676-2140-208
9	Casing Gasket		1	364-2110-598	364-0804-598	364-0805-598	364-2171-598	364-0807-598	364-2168-598
21	Gland		2	372-0606-104	372-0606-104	372-0606-104	372-0607-104	372-0607-104	372-0610-104
38	Bearing		1	068-0362-647	068-0362-647	068-0362-647	068-0364-647	068-0364-647	068-0362-647
47	Bearing		1	068-1912-647	068-1912-647	068-1912-647	068-1914-647	068-1914-647	068-1912-647
52	Lantern Ring*		2	676-1462-512	676-1462-512	676-1462-512	676-1943-512	676-1943-512	676-7030-509
23	Packing			564-0179-802	564-0179-802	564-0179-802	564-0180-802	564-0180-802	564-0181-802
	Qty Required*			12	12	12	14	14	12
	Repair Kit			476-0634-644	476-0634-644	476-0634-644	476-0635-644	476-0635-644	476-0914-644
	Overhaul Kit			476-0375-483	476-0375-483	476-0375-483	476-0376-483	476-0376-483	476-0919-483
	Rotating Assy			700-0659-483	700-0488-483	700-0089-483	700-0831-483	700-0540-483	700-0693-483

* Not all pump assemblies contain a lantern ring. When Lantern ring is present, subtract 2 pieces of packing.

FAIRBANKS NIJHUIS®
1800, 1900 MODELS

1800 VERTICAL SPLIT CASE PARTS LIST

POWER SERIES				2			3		
ITEM NUMBER	COMPONENT TYPE	OTHER	QTY.	2.5"1843BF	3"1844F	4"1843AF	4"1843CF	4"1843DF	4"1844F
8 & 69	Casing Assy	125# x 125#	1	179-1445-010	179-1447-010	179-1451-010	179-1451-010	179-2522-010	179-1452-010
8 & 69	Casing Assy	125# x 250#	1	179-2351-010	179-2106-010	179-2108-010	179-2108-010	179-2523-010	179-2112-010
8 & 69	Casing Assy	250# x 250#	1	179-1423-010	179-1425-010	179-1429-010	179-1429-010	179-2524-010	179-1430-010
59	Impeller		1	443-2295-225	443-2266-225	443-2112-208	443-0147-208	443-2984-225	443-2115-208
65	Shaft		1	728-0946-063	728-0946-063	728-0947-063	728-0947-063	728-0947-063	728-0947-063
65	Shaft (optional)		1	728-0946-109	728-0946-109	728-0947-109	728-0947-109	728-0947-109	728-0947-109
64	Shaft Sleeve		2	756-0642-644	756-0642-644	756-0643-644	756-0643-644	756-0643-644	756-0643-644
66	Case Wear Ring		2	676-1745-208	676-1746-208	676-1720-208	676-1747-208	676-2136-208	676-1747-208
9	Casing Gasket		1	364-1263-598	364-1265-598	364-0099-598	364-0099-598	364-2165-598	364-1268-598
21	Gland		2	372-0602-104	372-0602-104	372-0603-104	372-0603-104	372-0608-104	372-0603-104
38	Bearing		1	068-0454-647	068-0454-647	068-0455-647	068-0455-647	068-0455-647	068-0455-647
47	Bearing		1	068-1907-647	068-1907-647	068-1908-647	068-1908-647	068-1908-647	068-1908-647
52	Lantern Ring*		1	676-1698-512	676-1698-512	676-1699-512	676-1699-512	676-1699-512	676-1699-512
23	Packing			564-0151-802	564-0151-802	564-0175-816	564-0175-816	564-0175-816	564-0175-816
	Qty Required*			12	12	10	10	10	10
	Repair Kit			476-0630-644	476-0630-644	476-0631-644	476-0631-644	476-0631-644	476-0631-644
	Overhaul Kit			476-0371-483	476-0371-483	476-0372-483	476-0372-483	476-1095-483	476-0372-483
	Rotating Assy			700-0084-483	700-0006-483	700-0009-483	700-0023-483	700-0742-483	700-0012-483

POWER SERIES				4				5	
ITEM NUMBER	COMPONENT TYPE	OTHER	QTY.	5"1842BF	5"1842CF	5"1843F	5"1844F	6"1842F	6"1843F
8 & 69	Casing Assy	125# x 125#	1	179-2135-010	179-2135-010	179-1454-010	179-1455-010	179-1456-010	179-1457-010
8 & 69	Casing Assy	125# x 250#	1	179-2249-010	179-2249-010	179-2114-010	179-2116-010	179-2118-010	179-2120-010
8 & 69	Casing Assy	250# x 250#	1	179-2136-010	179-2136-010	179-1432-010	179-1433-010	179-1434-010	179-1435-010
59	Impeller		1	443-0656-208	443-2300-225	443-2117-208	443-2118-225	443-2116-208	443-2119-225
65	Shaft		1	728-0948-063	728-0948-063	728-0948-063	728-0948-063	728-0948-063	728-0949-063
65	Shaft (optional)		1	728-0948-109	728-0948-109	728-0948-109	728-0948-109	728-0948-109	728-0949-109
64	Shaft Sleeve		2	756-0644-644	756-0644-644	756-0644-644	756-0644-644	756-0644-644	756-0645-644
66	Case Wear Ring		2	676-1748-208	676-1748-208	676-1748-208	676-1748-208	676-1748-208	676-1750-208
9	Casing Gasket		1	364-0809-598	364-0809-598	364-1270-598	364-1270-598	364-1271-598	364-1272-598
21	Gland		2	372-0604-104	372-0604-104	372-0604-104	372-0604-104	372-0604-104	372-0605-104
38	Bearing		1	068-0456-647	068-0456-647	068-0456-647	068-0456-647	068-0456-647	068-0458-647
47	Bearing		1	068-0359-647	068-0359-647	068-1909-647	068-1909-647	068-1909-647	068-0160-647
52	Lantern Ring*		1	676-1700-512	676-1700-512	676-1700-512	676-1700-512	676-1700-512	676-1701-512
23	Packing			564-0176-816	564-0176-816	564-0176-816	564-0176-816	564-0176-816	564-0177-816
	Qty Required*			12	12	12	12	12	12
	Repair Kit			476-0632-483	476-0632-483	476-0632-483	476-0632-644	476-0632-644	476-0633-644
	Overhaul Kit			476-0451-483	476-0451-483	476-0451-483	476-0373-483	476-0373-483	476-0374-483
	Rotating Assy			700-0101-483	700-0484-483	700-0014-483	700-0015-483	700-0025-483	700-0018-483

POWER SERIES				5						
ITEM NUMBER	COMPONENT TYPE	OTHER	QTY.	6"1843BF	6"1843CF	6"1844BF	6"1844CF	6"1845F	8"1842F	8"1844BF
8 & 69	Casing Assy	125# x 125#	1	179-1457-010	179-1457-010	179-2103-010	179-2103-010	179-1458-010	179-1461-010	179-2077-010
8 & 69	Casing Assy	125# x 250#	1	179-2120-010	179-2120-010	179-2254-010	179-2254-010	179-2122-010	179-2124-010	179-2128-010
8 & 69	Casing Assy	250# x 250#	1	179-1435-010	179-1435-010	179-2102-010	179-2102-010	179-1436-010	179-1439-010	179-2079-010
59	Impeller		1	443-0649-208	443-2983-225	443-0658-225	443-2298-208	443-2120-225	443-2119-225	443-0476-208
65	Shaft		1	728-0949-063	728-0949-063	728-0949-063	728-0949-063	728-0949-063	728-0949-063	728-0949-063
65	Shaft (optional)		1	728-0949-109	728-0949-109	728-0949-109	728-0949-109	728-0949-109	728-0949-109	728-0949-109
64	Shaft Sleeve		2	756-0645-644	756-0645-644	756-0645-644	756-0645-644	756-0645-644	756-0645-644	756-0645-644
66	Case Wear Ring		2	676-1750-208	676-1750-208	676-1989-208	676-1750-208	676-1750-208	676-1750-208	676-0018-208
9	Casing Gasket		1	364-1272-598	364-1272-598	364-0802-598	364-0802-598	364-1273-598	364-1274-598	364-1276-598
21	Gland		2	372-0605-104	372-0605-104	372-0605-104	372-0605-104	372-0605-104	372-0605-104	372-0605-104
38	Bearing		1	068-0458-647	068-0458-647	068-0458-647	068-0458-647	068-0458-647	068-0458-647	068-0458-647
47	Bearing		1	068-0160-647	068-0160-647	068-0160-647	068-0160-647	068-0160-647	068-0160-647	068-0160-647
52	Lantern Ring*		1	676-1701-512	676-1701-512	676-1701-512	676-1701-512	676-1701-512	676-1701-512	676-1701-512
23	Packing			564-0177-816	564-0177-816	564-0177-816	564-0177-816	564-0177-816	564-0177-816	564-0177-816
	Qty Required*			12	12	12	12	12	12	12
	Repair Kit		1	476-0633-644	476-0633-644	476-0633-644	476-0633-644	476-0633-644	476-0633-644	476-0633-644
	Overhaul Kit		1	476-0374-483	476-0374-483	476-0374-483	476-0374-483	476-0374-483	476-0374-483	476-0374-483
	Rotating Assy		1	700-0250-483	700-0333-483	700-0486-483	700-0487-483	700-0019-483	700-0027-483	700-0021-483

* Not all pump assemblies contain a lantern ring. When Lantern ring is present, subtract 2 pieces of packing.

MODEL 1900 PARTS LIST

POWER SERIES				4A	5A
ITEM NUMBER	COMPONENT TYPE	OTHER	QTY.	5"1924F	6"1924F
8 & 74	Casing	125# x 250#	1	179-2495-055	179-2497-055
8 & 74	Casing	250# x 250#	1	179-2496-055	179-2498-055
67	Impeller 1st Stage		1	443-2979-225	443-2981-225
59	Impeller 2nd Stage		1	443-2978-225	443-2980-225
71	Shaft		1	728-7292-076	728-7293-076
71	Shaft (optional)		1	728-7292-116	728-7293-116
57 & 65	Shaft Sleeve		2	756-0690-644	756-0691-644
28	Case Wear Ring		2	676-2118-208	676-2120-208
61	Bushing		1	136-1637-226	136-1638-226
9	Casing Gasket		1	364-2141-598	364-2142-598
21	Gland		2	372-0609-104	372-0605-104
38	Bearing Item 38		1	068-1909-647	068-0160-647
47	Bearing Item 47		2	068-0022-647	068-0023-647
52	Lantern Ring			676-2119-512	676-2121-512
	Qty Required*			1	2
23	Packing			564-0176-816	564-0177-816
	Qty Required*			9	12
	Repair Kit		1	476-1090-644	476-1091-644
	Overhaul Kit		1	476-1092-483	476-1093-483
	Rotating Assy		1	700-8225-483	700-8261-483

POWER SERIES				3	4	5		
ITEM NUMBER	COMPONENT TYPE	OTHER	QTY.	4"1922F	5"1922F	6"1923F	6"1923BF	6"1922AF
8 & 74	Casing	125# x 250#	1	179-1637-010	179-2288-010	179-2431-055	179-2431-055	179-1640-010
8 & 74	Casing	250# x 250#	1	179-1641-010	179-2292-010	179-2432-055	179-2432-055	179-1644-010
67	Impeller 1st Stage		1	443-2099-208	443-2100-208	443-3151-208	443-3155-208	443-2134-208
59	Impeller 2nd Stage		1	443-2098-208	443-2101-208	443-3153-208	443-3157-208	443-2133-208
71	Shaft		1	728-1041-063	728-1042-063	728-1043-063	728-1043-063	728-1043-063
71	Shaft (optional)		1	728-1041-109	728-1042-109	728-1043-109	728-1043-109	728-1043-109
65	Shaft Sleeve		2	756-0643-644	756-0644-644	756-0645-644	756-0645-644	756-0645-644
69	Case Wear Ring		2	676-1013-208	676-1012-208	676-2150-208	676-2150-208	676-1750-208
61	Bushing		1	136-1321-226	136-1322-226	136-1323-226	136-1323-226	136-1323-226
62	Sleeve		1	756-0633-644	756-0634-644	756-0635-644	756-0635-644	756-0635-644
9	Casing Gasket		1	364-1302-598	364-1224-598	364-2206-598	364-2206-598	364-1332-598
21	Gland		2	372-0603-104	372-0604-104	372-0605-104	372-0605-104	372-0605-104
38	Bearing Item 38		1	068-0455-647	068-0456-647	068-0458-647	068-0458-647	068-0458-647
47	Bearing Item 47		1	068-1908-647	068-1909-647	068-0160-647	068-0160-647	068-0160-647
52	Lantern Ring			676-1699-512	676-1700-512	676-1701-512	676-1701-512	676-1701-512
	Qty Required*			1	1	1	1	1
23	Packing			564-0175-816	564-0176-816	564-0177-816	564-0177-816	564-0177-816
	Qty Required*			9	11	11	11	11
	Repair Kit		1	476-0644-644	476-0645-644	476-0646-644	476-0646-644	476-0646-644
	Overhaul Kit		1	476-0378-483	476-0379-483	476-0380-483	476-0380-483	476-0380-483
	Rotating Assy		1	700-0037-483	700-0038-483	700-0825-483	700-0845-483	700-0039-483

* Not all pump assemblies contain a lantern ring. When Lantern ring is present, subtract 1 piece of packing per lantern ring.

1800 HORIZONTAL & VERTICAL SPLIT CASE PACKING REPAIR KITS

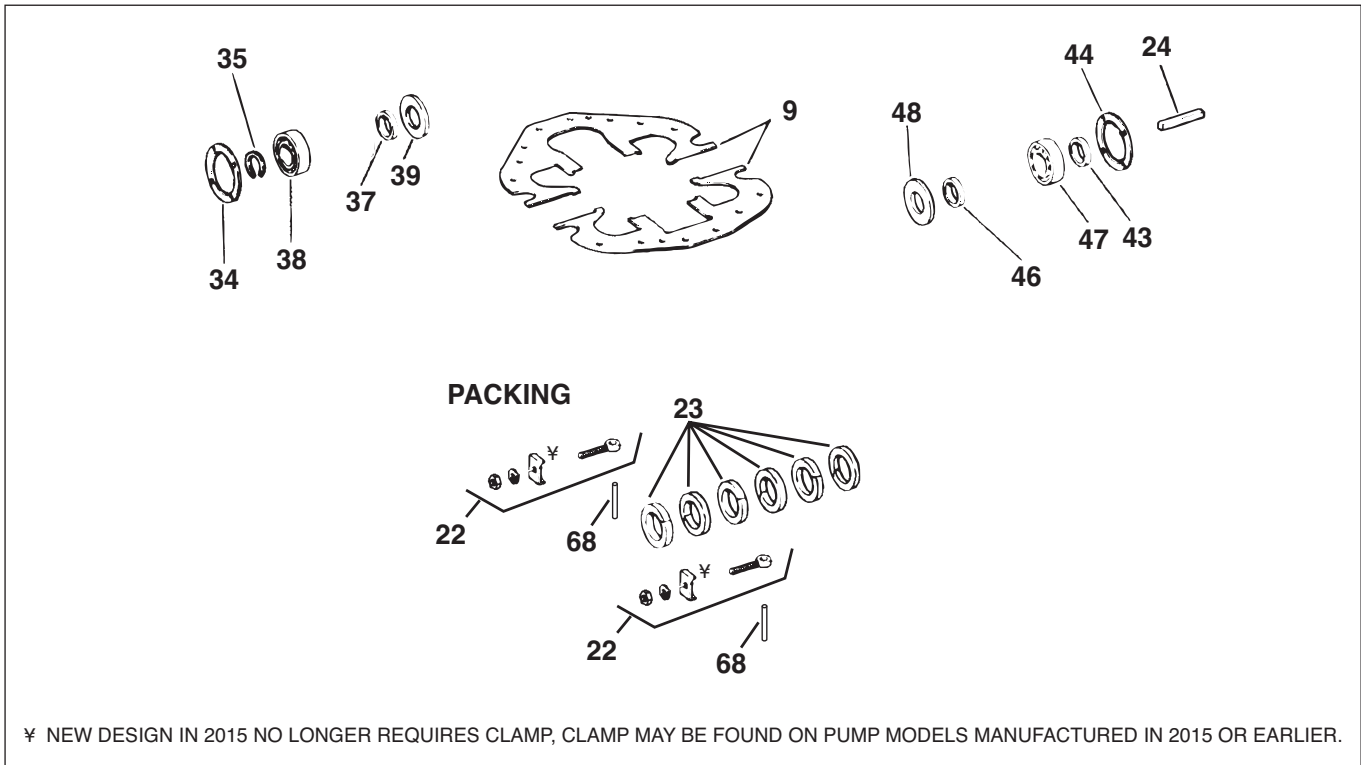

PARTS INCLUDED IN PACKING/SEAL REPAIR KITS

POWER SERIES	PACKING KIT
1	476-0629-644
2	476-0630-644
3	476-0631-644
4	476-0632-644
4*	476-0632-483
4A	476-0912-644
5	476-0633-644
5A	476-0913-644
6B	476-0634-644
7	476-0635-644
7A	476-0914-644

PC #	PART DESCRIPTION	MATERIAL CODE
		644
		BF
9	Gasket	598
22	Swingbolt Assy	644
23	Packing	802
24	Coupling Key	087
34	Gasket	653
35	Retaining Ring	088
37	Grease Seal	653
38	Bearing	647
39	Slinger	478
43	Grease Seal	653
44	Gasket	614
46	Grease Seal	653
47	Bearing	647
48	Slinger	478
68	Drive Pin PS #1, 2 Only	104

*Applies only to pump models 5" 1822BF, CF & DF and 5" 1842BF, CF & DF

1800 HORIZONTAL & VERTICAL SPLIT CASE OVERHAUL KITS

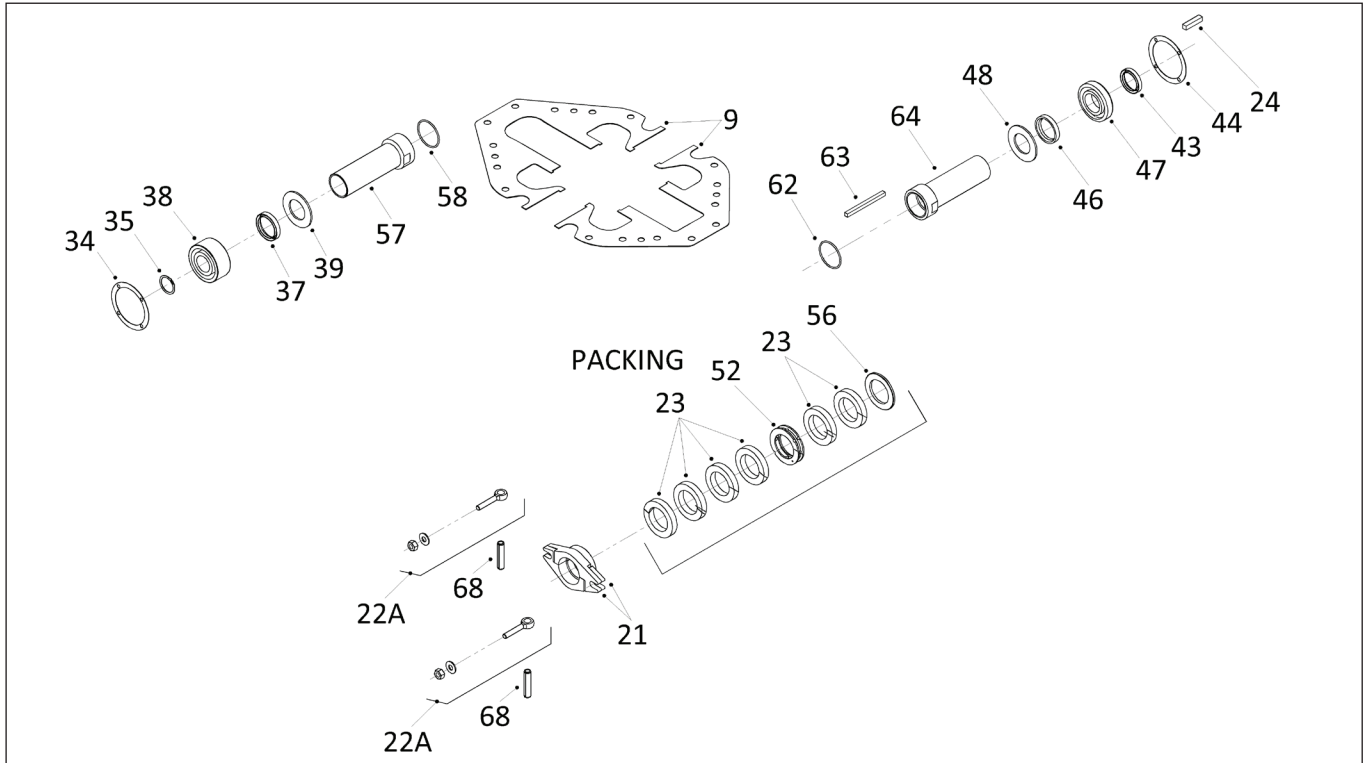

PARTS INCLUDED IN OVERHAUL KIT

POWER SERIES	OVERHAUL KIT
2	476-0371-483
3	476-0372-483
4	476-0373-483
4*	476-0451-483
4**	476-1095-483
4A	476-0917-483
5	476-0374-483
5A	476-0918-483
6B	476-0375-483
7	476-0376-483
7A	476-0919-483
7A	476-0914-644

* Applies only to pump models 5" 1822BF, CF & DF and 5" 1842BF, CF & DF

** Applies only to pump models 4" 1823DF and 4" 1843DF

PC #	PART DESCRIPTION	MATERIAL CODE
		644
		BF
9	Gasket	598
21	Packing Gland	208
22A	Swingbolt Assy	644
23	Packing	802
24	Coupling Key	087
34	Gasket	653
35	Retaining Ring	088
37	Grease Seal	653
38	Bearing	647
39	Slinger	478
43	Grease Seal	653
44	Gasket	614
46	Grease Seal	653
47	Bearing	647
48	Slinger	478
52	Lantern Ring	512
56	Bushing	208
57	Sleeve	208
58	O Ring	457
62	O Ring	457
63	Impeller Key	107
64	Sleeve	208
68	Drive Pins PS #2 Only	104

1800 HORIZONTAL & VERTICAL SPLIT CASE ROTATING ASSEMBLIES

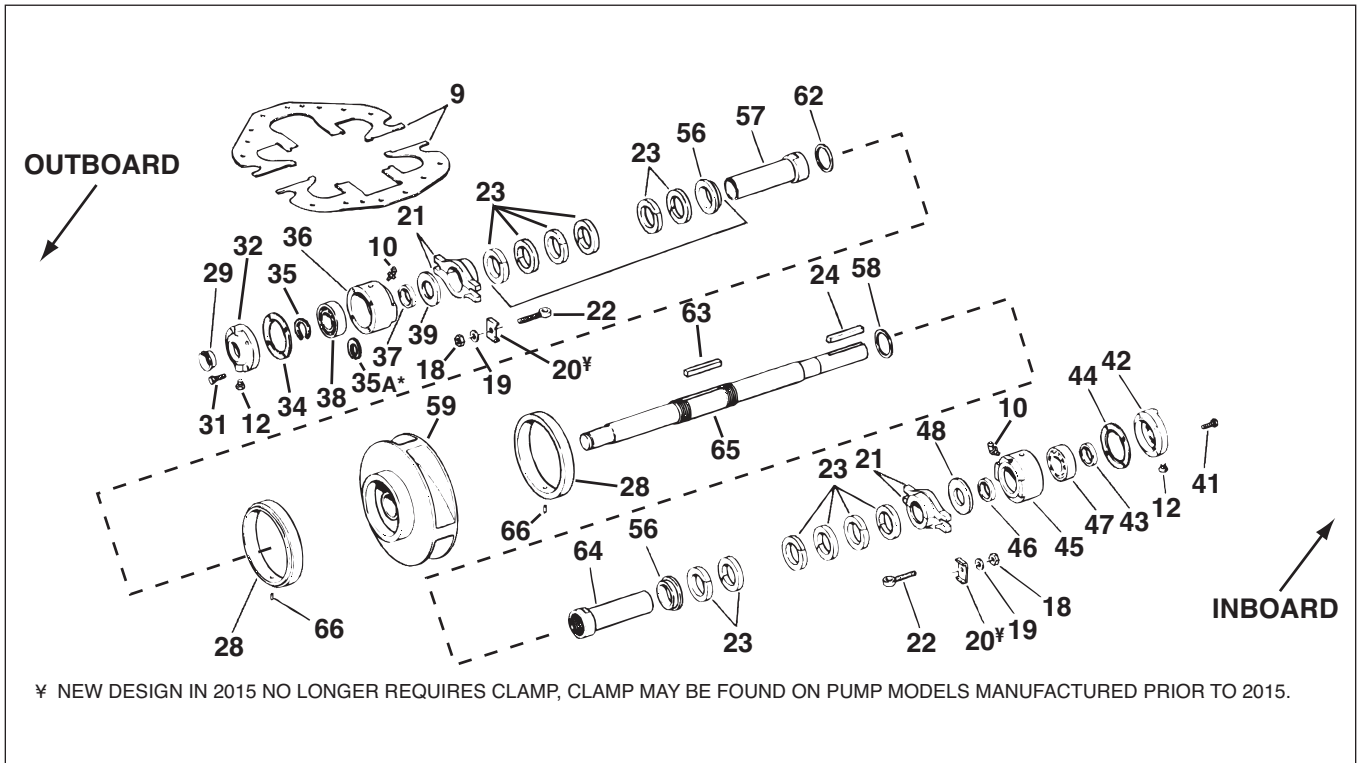

PUMP MODEL	POWER SERIES	PART NUMBER
2.5"1823BF/2.5"1843BF	2	700-0084-483
3"1824F/3"1844F	2	700-0006-483
4"1823AF/4"1843AF	3	700-0009-483
4"1823CF/4"1843CF	3	700-0023-483
4"1823DF/4"1843DF	3	700-0742-483
4"1824F/4"1844F	3	700-0012-483
5"1822BF/5"1842BF	4	700-0101-483
5"1822CF/5"1842CF	4	700-0484-483
5"1822DF	4	700-0496-483
5"1823F/5"1823F	4	700-0014-483
5"1823AF	4	700-0261-483
5"1824F/5"1844F	4	700-0015-483
6"1822F/6"1842F	4	700-0025-483
6"1822HHF	4A	700-0745-483
6"1823F/6"1843F	5	700-0018-483

PUMP MODEL	POWER SERIES	PART NUMBER
6"1823BF/6"1843BF	5	700-0250-483
6"1823CF/6"1843CF	5	700-0333-483
6"1824BF/6"1844BF	5	700-0486-483
6"1824CF/6"1844CF	5	700-0487-483
6"1825F/6"1825F	5	700-0019-483
8"1822F/8"1842F	5	700-0027-483
8"1824BF/8"1844BF	5	700-0021-483
6"1823HHF	5A	700-0743-483
10"1823CF	6B	700-0488-483
10"1824F	6B	700-0089-483
8"1825F	6B	700-0658-483
8"1825AF	6B	700-0659-483
12"1825AF	7	700-0540-483
8"1826F	7	700-0831-483
10"1824DF	7A	700-0693-483

PC #	PART DESCRIPTION
9	Gasket
10	Grease Fitting
12	Plug
18	Nut
19	Washer
20¥	Gland Clamp
21	Packing Gland
22	Swing Bolt
23	Packing
24	Coupling Key
28	Case Ring
29	Protector
31	Capscrew
34	Gasket
35	Retaining Ring
36	Cartridge
37	Grease Seal
38	Bearing
39	Slinger
41	Capscrew
42	Cartridge Seal
43	Grease Seal
44	Gasket
45	Cartridge
46	Grease Seal
47	Bearing
48	Slinger
56	Bushing
57	Sleeve
58	O Ring
59	Impeller
62	O Ring
63	Impeller Key
64	Sleeve
66	Pin

MODEL 1900 PACKING REPAIR KITS

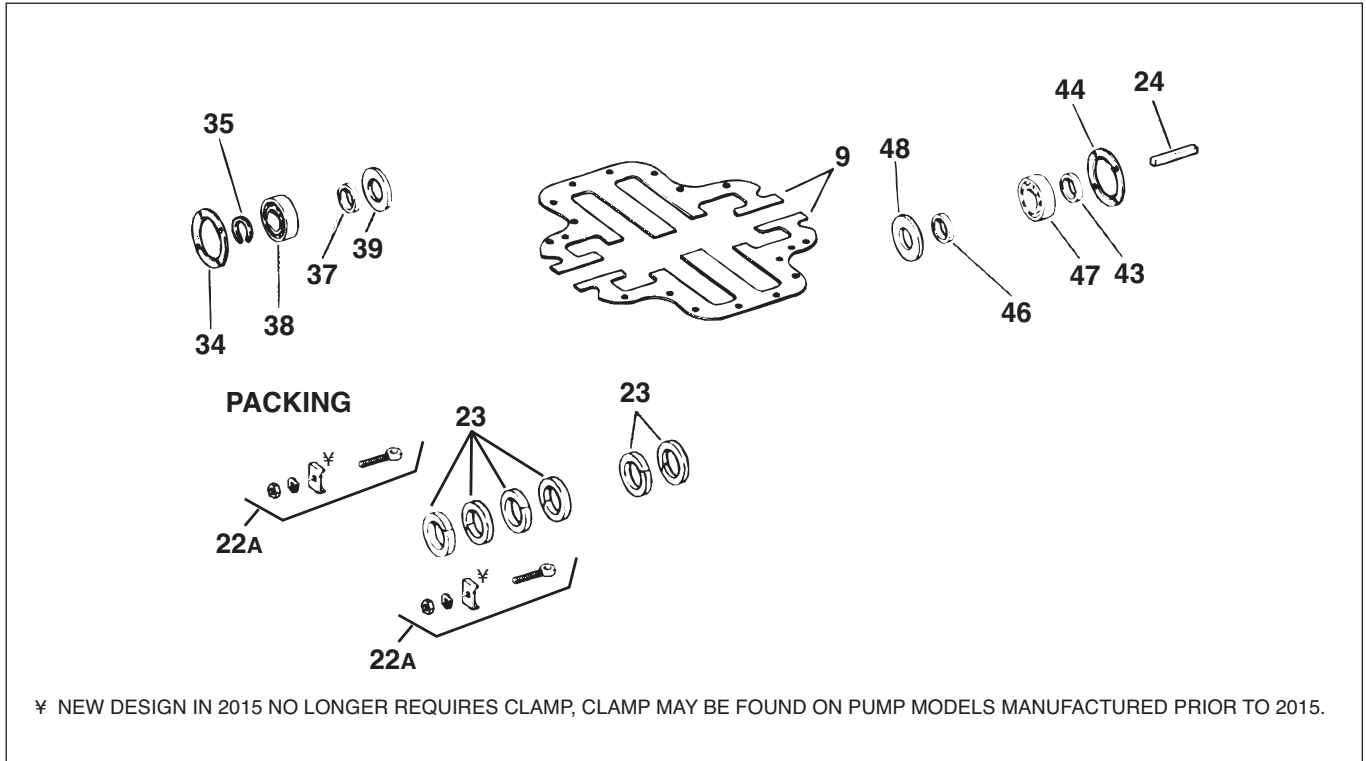

PARTS INCLUDED IN PACKING/SEAL REPAIR KITS

POWER SERIES	PACKING KIT
3	476-0644-644
4	476-0645-644
4A	476-1090-644
5	476-0646-644
5A	476-1091-644

PC #	PART DESCRIPTION	MATERIAL CODE
9	Gasket	598
22A	Swingbolt Assy	644
23	Packing	802
24	Coupling Key	087
34	Gasket	614
35	Retaining Ring	088
37	Grease Seal	653
38	Bearing	647
39	Slinger	478
43	Grease Seal	653
44	Gasket	614
46	Grease Seal	653
47	Bearing	647
48	Slinger	478

MODEL 1900 OVERHAUL KITS

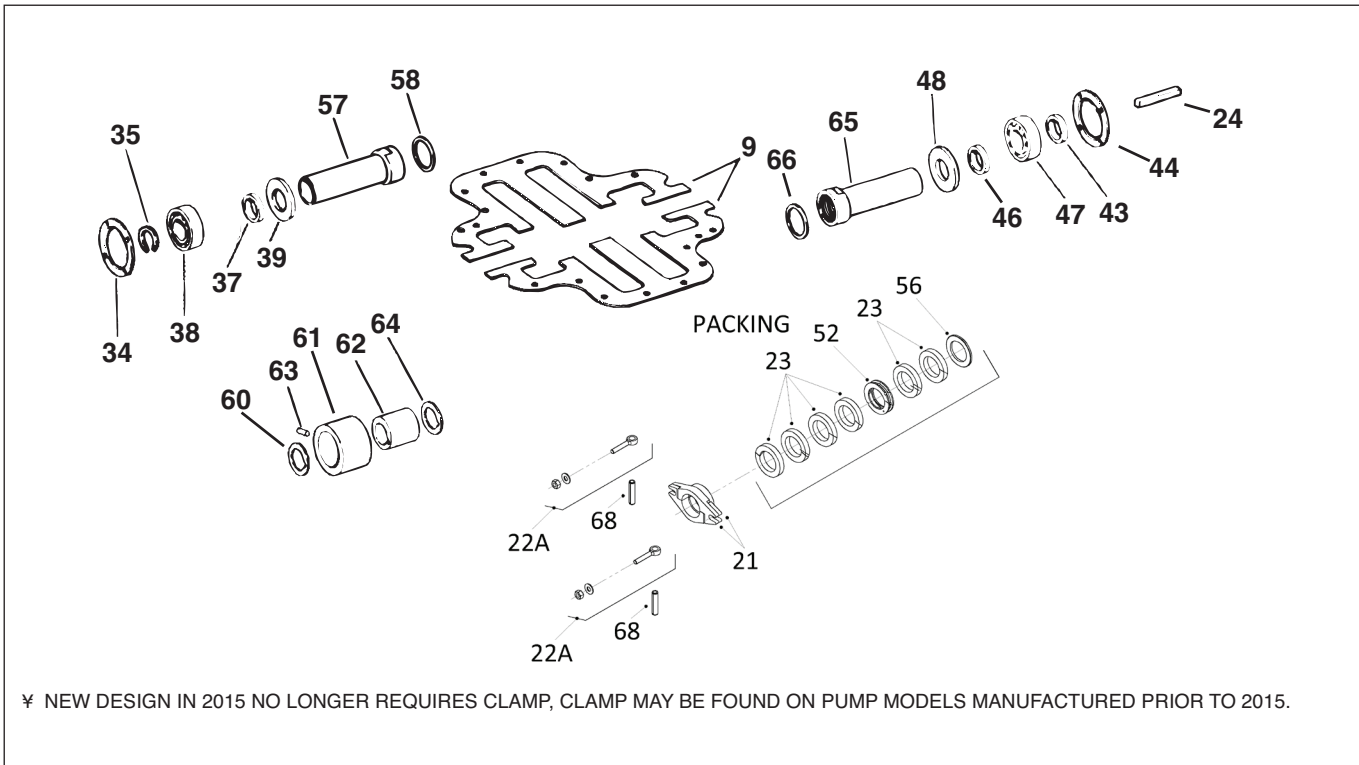

¥ NEW DESIGN IN 2015 NO LONGER REQUIRES CLAMP, CLAMP MAY BE FOUND ON PUMP MODELS MANUFACTURED PRIOR TO 2015.

PARTS INCLUDED IN OVERHAUL KIT

POWER SERIES	OVERHAUL KIT
3	476-0378-483
4	476-0379-483
4A	476-1092-483
5	476-0380-483
5A	476-1093-483

PC #	PART DESCRIPTION	MATERIAL CODE
9	Gasket	598
21	Packing Gland	010
22A	Swingbolt Assy	644
23	Packing	802
24	Coupling Key	087
34	Gasket	614
35	Retaining Ring	088
37	Grease Seal	653
38	Bearing	647
39	Slinger	478
43	Grease Seal	653
44	Gasket	614
46	Grease Seal	653
47	Bearing	647
48	Slinger	478
52	Lantern Ring	512
56	Bushing	208
57	Sleeve	208
58	O Ring	457
60	O Ring	457
61	Bushing	226
62	Sleeve	215
63	Pin	360
64	O Ring	457
65	Sleeve	208
66	O Ring	457
68	Impeller Key	107

MODEL 1900 ROTATING ASSEMBLIES

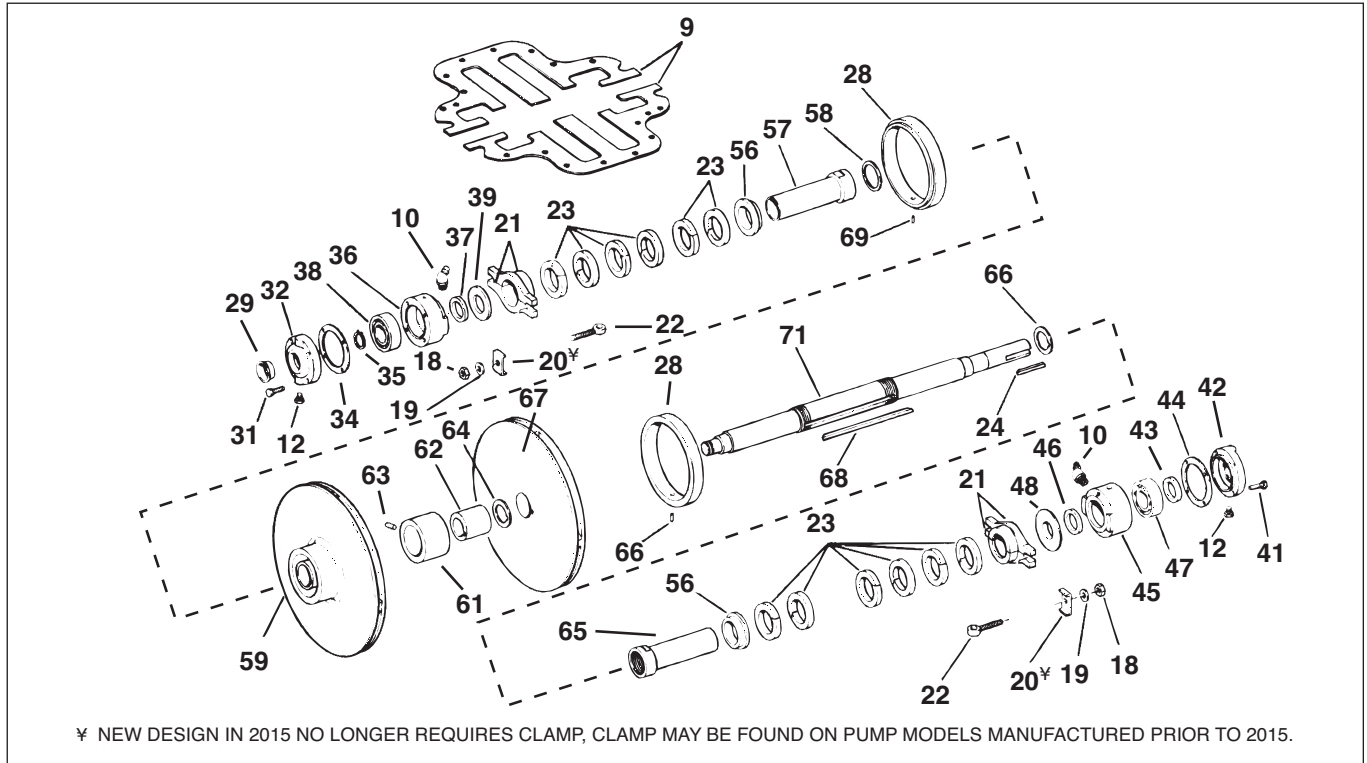

PUMP MODEL	POWER SERIES	PART NUMBER
4"1922F	3	700-0037-483
5"1922F	4	700-0038-483
5"1924F	4A	700-8225-483
6"1923F	5	700-0825-483
6"1923BF	5	700-0845-483
6"1922AF	5	700-0039-483
6"1924F	5A	700-8261-483

PC #	PART DESCRIPTION
9	Gasket
10	Grease Fitting
12	Plug
18	Nut
19	Washer
20¥	Clamp
21	Packing Gland
22	Swing Bolt
23	Packing
28	Case Ring
29	Protector
31	Capscrew
32	Cartridge Seal
34	Gasket
35	Retaining Ring
36	Cartridge
37	Grease Seal
38	Bearing
39	Slinger
41	Capscrew

PC #	PART DESCRIPTION
42	Cartridge Cap
43	Grease Seal
44	Gasket
45	Cartridge
46	Grease Seal
47	Bearing
48	Slinger
56	Bushing
57	Sleeve
58	O Ring
59	Impeller
62	Sleeve
63	Pin
64	O Ring
65	Sleeve
66	O Ring
67	Impeller
69	Pin
71	Shaft

WARRANTY

Seller warrants equipment (and its component parts) of its own manufacture against defects in materials and workmanship under normal use and service for one (1) year from the date of installation or start-up, or for eighteen (18) months after the date of shipment, whichever occurs first. Seller does not warrant accessories or components that are not manufactured by Seller; however, to the extent possible, Seller agrees to assign to Buyer its rights under the original manufacturer's warranty, without recourse to Seller. Buyer must give Seller notice in writing of any alleged defect covered by this warranty (together with all identifying details, including the serial number, the type of equipment, and the date of purchase) within thirty (30) days of the discovery of such defect during the warranty period. No claim made more than 30 days after the expiration of the warranty period shall be valid. Guarantees of performance and warranties are based on the use of original equipment manufactured (OEM) replacement parts. Seller assumes no responsibility or liability if alterations, non-authorized design modifications and/or non-OEM replacement parts are incorporated. If requested by Seller, any equipment (or its component parts) must be promptly returned to Seller prior to any attempted repair, or sent to an authorized service station designated by Seller, and Buyer shall prepay all shipping expenses. Seller shall not be liable for any loss or damage to goods in transit, nor will any warranty claim be valid unless the returned goods are received intact and undamaged as a result of shipment. Repaired or replaced material returned to customer will be shipped F.O.B., Seller's factory. Seller will not give Buyer credit for parts or equipment returned to Seller, and will not accept delivery of any such parts or equipment, unless Buyer has obtained Seller's approval in writing. The warranty extends to repaired or replaced parts of Seller's manufacture for ninety (90) days or for the remainder of the original warranty period applicable to the equipment or parts being repaired or replaced, whichever is greater. This warranty applies to the repaired or replaced part and is not extended to the product or any other component of the product being repaired. Repair parts of its own manufacture sold after the original warranty period are warranted for a period of one (1) year from shipment against defects in materials and workmanship under normal use and service. This warranty applies to the replacement part only and is not extended to the product or any other component of the product being repaired. Seller may substitute new equipment or improve part(s) of any equipment judged defective without further liability. All repairs or services performed by Seller, which are not covered by this warranty, will be charged in accordance with Seller's standard prices then in effect.

THIS WARRANTY IS THE SOLE WARRANTY OF SELLER AND SELLER HEREBY EXPRESSLY DISCLAIMS AND BUYER WAIVES ALL OTHER WARRANTIES EXPRESSED, IMPLIED IN LAW OR IMPLIED IN FACT, INCLUDING ANY WARRANTIES OF MERCHANTABILITY OR FITNESS FOR A PARTICULAR PURPOSE. Seller's sole obligation under this warranty shall be, at its option, to repair or replace any equipment (or its component parts) which has a defect covered by this warranty, or to refund the purchase price of such equipment or part. Under the terms of this warranty, Seller shall not be liable for (a) consequential, collateral, special or liquidated losses or damages; (b) equipment conditions caused by normal wear and tear, abnormal conditions of use, accident, neglect, or misuse of said equipment; (c) the expense of, and loss or damage caused by, repairs or alterations made by anyone other than the Seller; (d) damage caused by abrasive materials, chemicals, scale deposits, corrosion, lightning, improper voltage, mishandling, or other similar conditions; (e) any loss, damage, or expense relating to or resulting from installation, removal or reinstallation of equipment; (f) any labor costs or charges incurred in repairing or replacing defective equipment or parts, including the cost of reinstalling parts that are repaired or replaced by Seller; (g) any expense of shipment of equipment or repaired or replacement parts; or (h) any other loss, damage or expense of any nature.

The above warranty shall not apply to any equipment which may be separately covered by any alternate or special warranties.

PERFORMANCE: In the absence of Certified Pump Performance Tests, equipment performance is not warranted or guaranteed. Performance curves and other information submitted to Buyer are approximate and no warranty or guarantee shall be deemed to arise as a result of such submittal. All testing shall be done in accordance with Seller's standard policy under Hydraulic Institute procedures.

LIABILITY LIMITATIONS: Under no circumstances shall the Seller have any liability under the Order or otherwise for liquidated damages or for collateral, consequential or special damages or for loss of profits, or for actual losses or for loss of production or progress of construction, regardless of the cause of such damages or losses. In any event, Seller's aggregate total liability under the Order or otherwise shall not exceed the contract price.

ACTS OF GOD: Seller shall in no event be liable for delays in delivery of the equipment or other failures to perform caused by fires, acts of God, strikes, labor difficulties, acts of governmental or military authorities, delays in transportation or procuring materials, or causes of any kind beyond Seller's control.

COMPLIANCE WITH LAW: Seller agrees to comply with all United States laws and regulations applicable to the manufacturing of the subject equipment. Such compliance shall include: The Fair Labor Standards Acts of 1938, as amended; Equal Employment Opportunity clauses of Executive Order 11246, as amended; Occupational Safety and Health Act of 1970 and the standards promulgated thereunder, if applicable. Since compliance with the various Federal, State, and Local laws and regulations concerning occupational health and safety, pollution or local codes are affected by the use, installation and operation of the equipment and other matters over which Seller has no control, Seller assumes no responsibility for compliance with those laws and regulations, whether by way of indemnity, warranty, or otherwise. It is incumbent upon the Buyer to specify equipment which complies with local codes and ordinances.



FAIRBANKS NIJHUIS®

3601 Fairbanks Avenue
Kansas City, KS 66106 U.S.A.
913-371-5000
www.FairbanksNijhuis.com