



Aplex Series

MA-120M(L)(H) Triplex Plunger Pump

No. of Plungers.....	3
Maximum Rated Speed	450 rpm
Stroke Length	4.25 in. 108.0 mm
Maximum Rated Power 120M, 120L, 120H	120.0 hp 89.4 kW
Maximum Rod Load 120M, 120L, 120H	7,452 lbs. 33.1 kN
Weight 120M	1,950 lbs.
120L.....	1,860 lbs.
120H	2,025 lbs.

ENGLISH UNITS

MA-120M

PLUNGER SIZE IN.	STUFFING BOX BORE IN.	MAX PSI	*GALLON PER/REV.	250 RPM GPM	300 RPM GPM	350 RPM GPM	400 RPM GPM	450 RPM GPM
2.250	3.250	1873	0.219	54.9	65.8	76.8	87.8	98.8
2.125	3.250	2100	0.196	48.9	58.7	68.5	78.3	88.1
2.000	2.875	2371	0.173	43.4	52.0	60.7	69.4	78.0
1.875	2.875	2697	0.152	38.1	45.7	53.3	61.0	68.6
1.750	2.875	3097	0.133	33.2	39.8	46.5	53.1	59.7
1.625	2.500	3250	0.114	28.6	34.3	40.1	45.8	51.5
1.500	2.500	3600	0.098	24.4	29.3	34.1	39.0	43.9
hp Required @ rpm				66.6	80.0	93.3	106.6	120.0

METRIC UNITS

MA-120M

PLUNGER SIZE MM	STUFFING BOX BORE MM	MAX PRESS. BAR	*LITER PER/REV.	250 RPM LPM	300 RPM LPM	350 RPM LPM	400 RPM LPM	450 RPM LPM
57.2	82.6	129.2	0.831	207.7	249.3	290.8	332.4	373.9
54.0	82.6	144.8	0.741	185.3	222.4	259.4	296.5	333.5
50.8	73.0	163.4	0.656	164.1	196.9	229.7	262.6	295.4
47.6	73.0	186.1	0.577	144.2	173.1	201.9	230.8	259.6
44.5	73.0	213.5	0.503	125.7	150.8	175.9	201.1	226.2
41.3	63.5	224.0	0.433	108.4	130.0	151.7	173.4	195.0
38.1	63.5	248.2	0.369	92.3	110.7	129.2	147.6	166.1
kW Required @ rpm				49.7	59.7	69.6	79.5	89.5

ENGLISH UNITS

MA-120L

PLUNGER SIZE IN.	STUFFING BOX BORE IN.	MAX PSI	*GALLON PER/REV.	250 RPM GPM	300 RPM GPM	350 RPM GPM	400 RPM GPM	450 RPM GPM
3.500	4.500	775	0.531	132.8	159.3	185.9	212.4	239.0
3.375	4.500	833	0.494	123.4	148.1	172.8	197.5	222.2
3.250	4.500	898	0.458	114.5	137.4	160.3	183.2	206.0
3.125	4.000	971	0.423	105.8	127.0	148.2	169.3	190.5
3.000	4.000	1054	0.390	97.5	117.0	136.6	156.1	175.6
2.875	4.000	1148	0.358	89.6	107.5	125.4	143.3	161.2
2.750	4.000	1254	0.328	82.0	98.4	114.7	131.1	147.5
2.625	4.000	1377	0.299	74.7	89.6	104.5	119.5	134.4
2.500	3.250	1518	0.271	67.7	81.3	94.8	108.4	121.9
2.375	3.250	1682	0.245	61.1	73.4	85.6	97.8	110.0
hp Required @ rpm				66.7	80.1	93.4	106.8	120.0

Aplex Series

MA-120M(L)(H) Triplex Plunger Pump

METRIC UNITS
MA-120L

PLUNGER SIZE MM	STUFFING BOX BORE MM	MAX PRESS. BAR	*LITER PER/ REV.	250 RPM LPM	300 RPM LPM	350 RPM LPM	400 RPM LPM	450 RPM LPM
88.9	114.3	53.4	2.010	502.5	603.0	703.5	804.0	904.5
85.3	114.3	57.4	1.869	467.3	560.8	654.2	747.7	841.1
82.6	114.3	62.0	1.733	433.3	520.0	606.7	693.3	780.0
79.4	101.6	67.0	1.602	400.6	480.7	560.8	641.0	721.1
76.2	101.6	72.6	1.477	369.3	443.1	517.0	590.8	664.7
73.0	101.6	79.1	1.356	339.1	406.9	474.7	542.5	610.3
69.9	101.6	86.4	1.241	310.2	372.3	434.3	496.4	558.4
66.7	101.6	95.0	1.131	282.7	339.2	395.7	452.3	508.8
63.5	82.6	104.6	1.026	256.4	307.7	358.9	410.2	461.5
60.3	82.6	116.0	0.926	231.4	277.6	323.9	370.2	416.5
kW Required @ rpm				49.7	59.7	69.6	79.6	89.5

ENGLISH UNITS
MA-120H

PLUNGER SIZE IN.	STUFFING BOX BORE IN.	MAX PSI	*GALLON PER/REV.	250 RPM GPM	300 RPM GPM	350 RPM GPM	400 RPM GPM	450 RPM GPM
2.000	2.875	2284	0.173	43.4	52.0	60.7	69.4	78.0
1.875	2.875	2397	0.152	38.1	45.7	53.3	61.0	68.6
1.750	2.875	3097	0.133	33.2	39.8	46.5	53.1	59.7
1.625	2.500	3592	0.114	28.6	34.3	40.1	45.8	51.5
1.500	2.500	4215	0.098	24.4	29.3	34.1	39.0	43.9
1.375	2.250	5016	0.082	20.5	24.6	28.7	32.8	36.9
hp Required @ rpm				47.9	57.5	67.0	76.6	89.5

METRIC UNITS
MA-120H

PLUNGER SIZE MM	STUFFING BOX BORE MM	MAX PRESS. BAR	*LITER PER/ REV.	250 RPM LPM	300 RPM LPM	350 RPM LPM	400 RPM LPM	450 RPM LPM
50.8	73.3	163.4	0.656	164.1	196.9	229.7	262.6	295.4
47.6	73.0	186.0	0.577	144.2	173.1	201.9	230.8	259.6
44.4	73.0	213.4	0.503	125.7	150.8	175.9	201.1	226.2
41.3	63.5	247.6	0.433	108.4	130.0	151.7	173.4	195.0
38.1	63.5	290.5	0.369	92.3	110.7	129.2	147.6	166.1
34.9	57.2	345.8	0.310	77.6	93.1	108.6	124.2	139.7
kW Required @ rpm				47.9	57.5	67.0	76.6	89.5

*Displacement based on 100% Volumetric Efficiency

Power based on 90% Mechanical Efficiency

$$I_{hp} = \frac{USGPM \times [\text{Discharge psig} - 1/2 \text{ Suction psig}]}{1542}$$

$$I_{kW} = \frac{M/HR \times [\text{Discharge Bar} - 1/2 \text{ Suction Bar}]}{32.4}$$

$$\text{Pump rpm} = \frac{USGPM \text{ Desired}}{USGPM \text{ per Revolution of Selected Plunger}}$$

$$\text{Pump rpm} = \frac{M/HR \text{ Desired}}{M' \text{ per Revolution of Selected Plunger}}$$

Aplex Series MA-120M(L)(H) Triplex Plunger Pump

MA-120M TRIPLEX PUMP (MEASUREMENTS SHOWN IN INCHES)

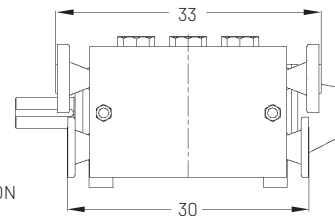
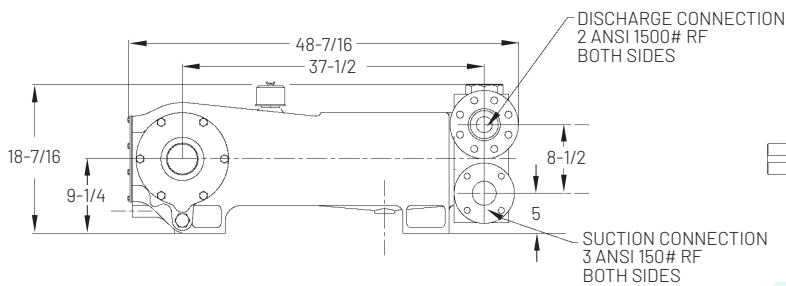
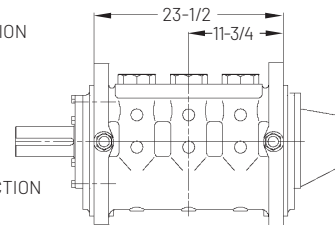
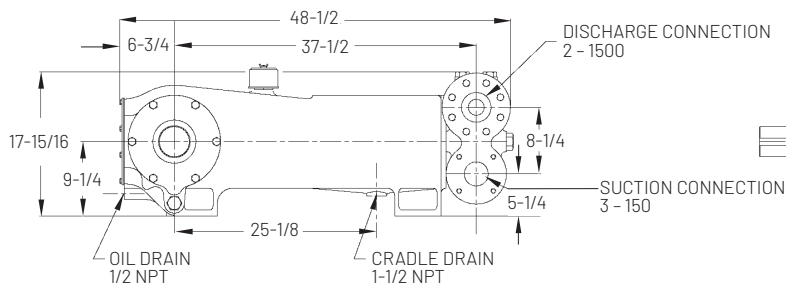
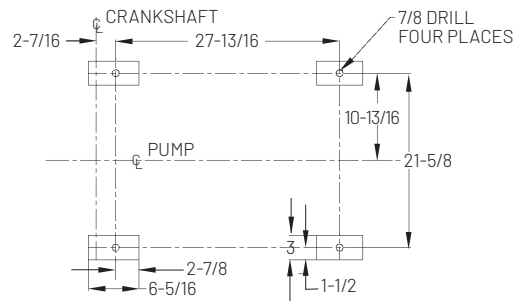
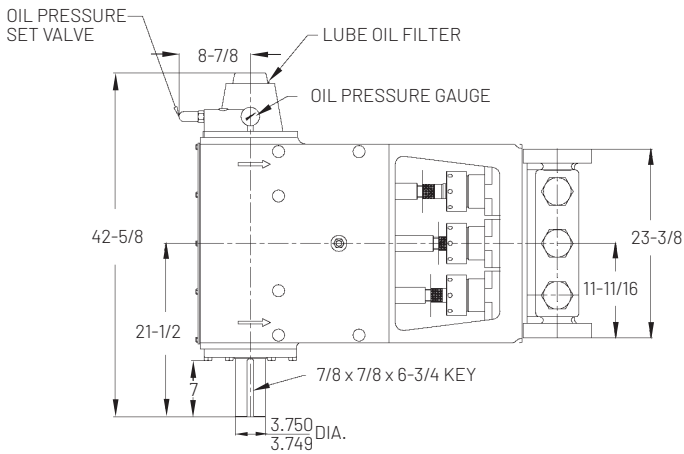

Aplex Series MA-120M(L)(H) Triplex Plunger Pump

MA-120L TRIPLEX PUMP (MEASUREMENTS SHOWN IN INCHES)

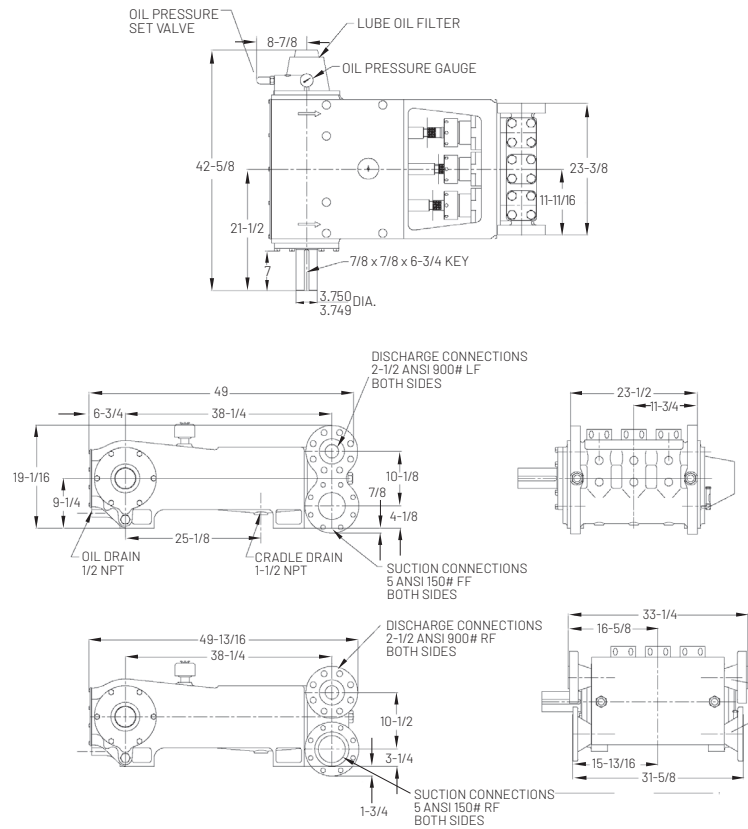

MA-120H-HD TRIPLEX PUMP (MEASUREMENTS SHOWN IN INCHES)

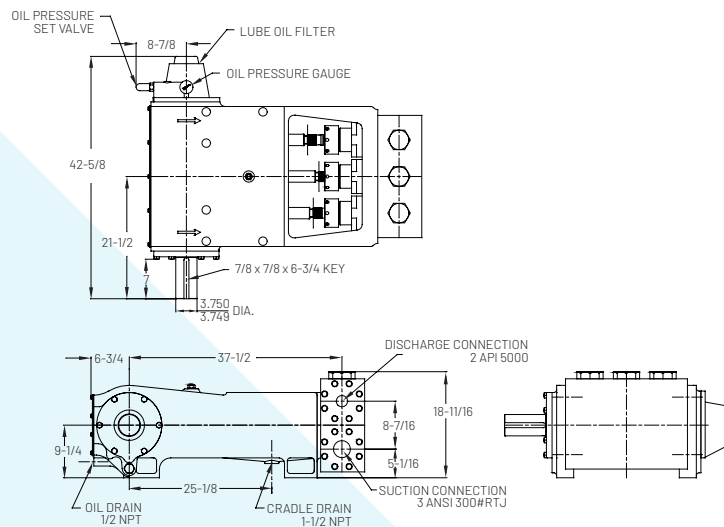



Aplex Series

MA-120M(L)(H) Triplex Plunger Pump

ENGINEERING DATA - MA-120M, MA-120L, MA-120H TRIPLEX PUMPS

POWER END ENGINEERING DATA

Max. Input hp @ Speed 120M, 120L, 120H.....	120 @ 450 rpm
Rated Continuous Plunger Load 120M, 120L, 120H.....	7,452 lbs.
Normal Continuous Speed Range 120M, 120L	150 to 400 rpm
Minimum Speed.....	100 rpm
Oil Capacity	18 U.S. Qts
Power End Oiling System	Pressure Lubrication
Power Frame, One-Piece	Cast Iron
Crosshead, Full Cylindrical	Cast Iron
Dia. x Length	5-3/4 x 6-3/16 in.
Crankshaft 120M, 120L, 120H.....	Ductile Iron
Crankshaft Diameters:	
At Tapered Roller Bearings	4 in.
At Crankpin Bearings, Dia. x Length	4 x 3 in.
Crosshead (Wrist) Pin, Case-Hardened and Ground	AISI 8620
Main Bearings, Tapered Roller	Timken
Crankpin Bearings, Precision Automotive	Steel Backed, Babbitt-Lined
Extension (Pony) Rod, 120M, 120L, 120H.....	316 S.ST.
Connecting Rod, Automotive Type	Ductile Iron
Average Crosshead Speed @ 450 rpm	318 fpm
Minimum Life Expectancy, Main Bearings, L ₁₀ 120M, 120H, 120L	45,000+ hr.

LIQUID END ENGINEERING DATA

Max. Continuous Working Pressure 120M	3,250 psi
120L.....	1,682 psi
120H	5,000 psi
Hydrostatic Test 120M	4,875 psi
120L	2,523 psi
120H.....	7,500 psi
Available Liquid End Materials, A.S.T.M.	
Stainless Steel Block 120M, 120L, 120H	Various Grades
Nickel Aluminum Bronze Casting 120M, 120L	B148-C955
Carbon Steel Block 120M, 120L, 120H	Various Grades
Ductile Iron Casting 120L	A536 80-55-06
Plunger Type Rokide (Chromium Oxide-Coated).....	316 S.ST. (Other types available include Tungsten Carbide, Ceramic)
Stuffing Boxes, Field-Removable and Replaceable	
Aluminum Bronze 120M, 120L	B148-C955
Carbon Steel 120M, 120L, 120H	1020
Stainless Steel 120L, 120M, 120H	Various Grades

Aplex Series

MA-120M(L)(H) Triplex Plunger Pump

Packing Types Available

Gland-Loaded, Non-Adjustable.....	Style 838
Spring-Loaded, Braided PTFE Coating & Aramid Fiber	Style 140, 141, 8921K
Spring-Loaded, Cup-Type	Style 120X

Valve Cover Dependant on Fluid End Material

Seals, Stuffing Boxes, Valve Covers, Cyl. Heads Nitrile

Disc Valve Types

Standard Disc Type, Acetal Resin 120M, 120L	Acetal
Optional Disc Type, Hardened and Lapped Stainless Steel	17-4 PH S.ST.
Optional, Abrasion Resistant Wing Guided	17-4 PH S.ST.

Valve Spring Material Inconel

Valve Seat, Liquid Passage Areas - Plate (Disc) Valves, (Acetal or S.ST.) 120M	2.35 sq.in.
120L	6.26 sq.in.
120H	2.30 sq.in.

Avg. Liquid Velocity @ 450 rpm

through Valves 120M.....	8.97 fps
120L	8.17 fps
120H	7.25 fps
through Suction Manifold 120M	4.47 fps
120L	3.90 fps
120H	2.00 fps
through Discharge Manifold 120M	10.09 fps
120L.....	15.62 fps
120H	15.62 fps

Aplex Series MA-120M(L)(H) Triplex Plunger Pump

MA-120M TRIPLEX PUMP (MEASUREMENTS SHOWN IN INCHES)

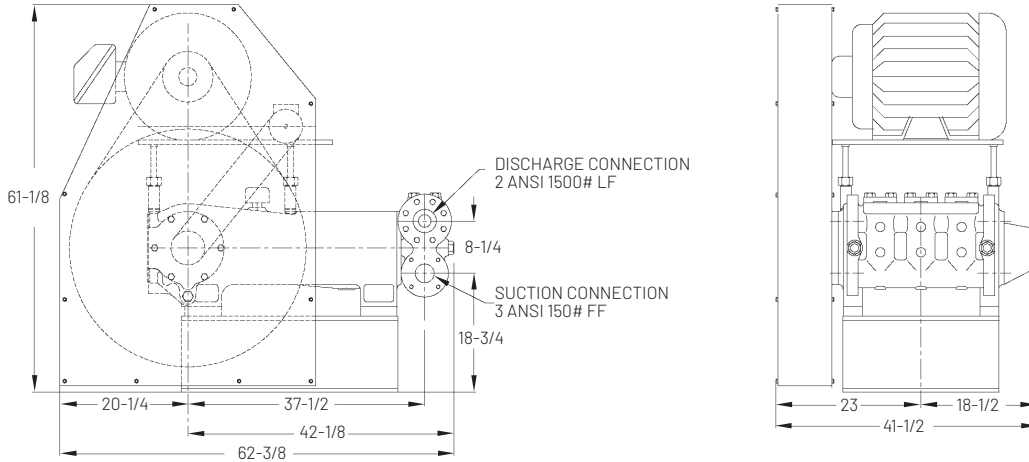

MA-120L TRIPLEX PUMP (MEASUREMENTS SHOWN IN INCHES)

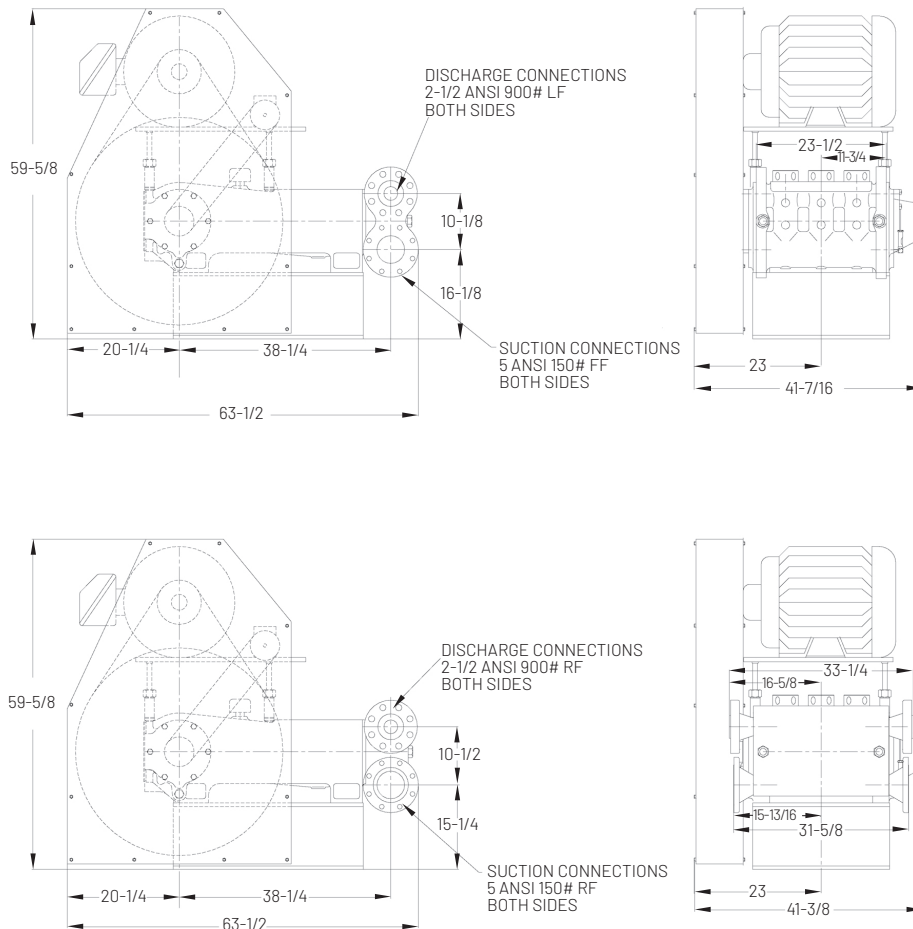

MA-120H TRIPLEX PUMP (MEASUREMENTS SHOWN IN INCHES)

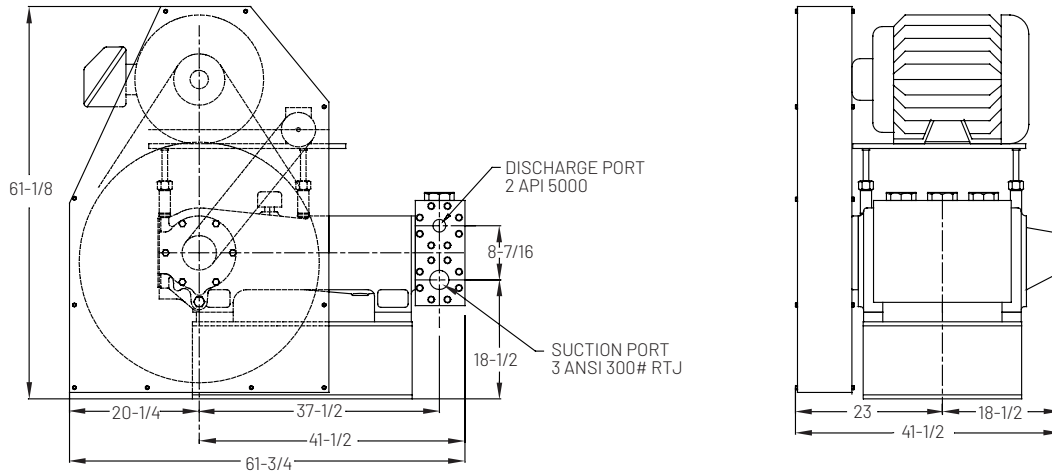

1101 MYERS PARKWAY,
ASHLAND, OH 44805
USA
Ph: 888.416.9513

490 Pinebush Road
Unit 4
Cambridge, Ontario N1T 0A5
Canada

pentair.com

All indicated Pentair trademarks and logos are property of Pentair. Third party registered and unregistered trademarks and logos are the property of their respective owners. Because we are continuously improving our products and services, Pentair reserves the right to change specifications without prior notice. Pentair is an equal opportunity employer.

MA1021 (10-15-20) ©2020 Pentair. All Rights Reserved.