

DESMI self-priming centrifugal pump

Type VAC-4001

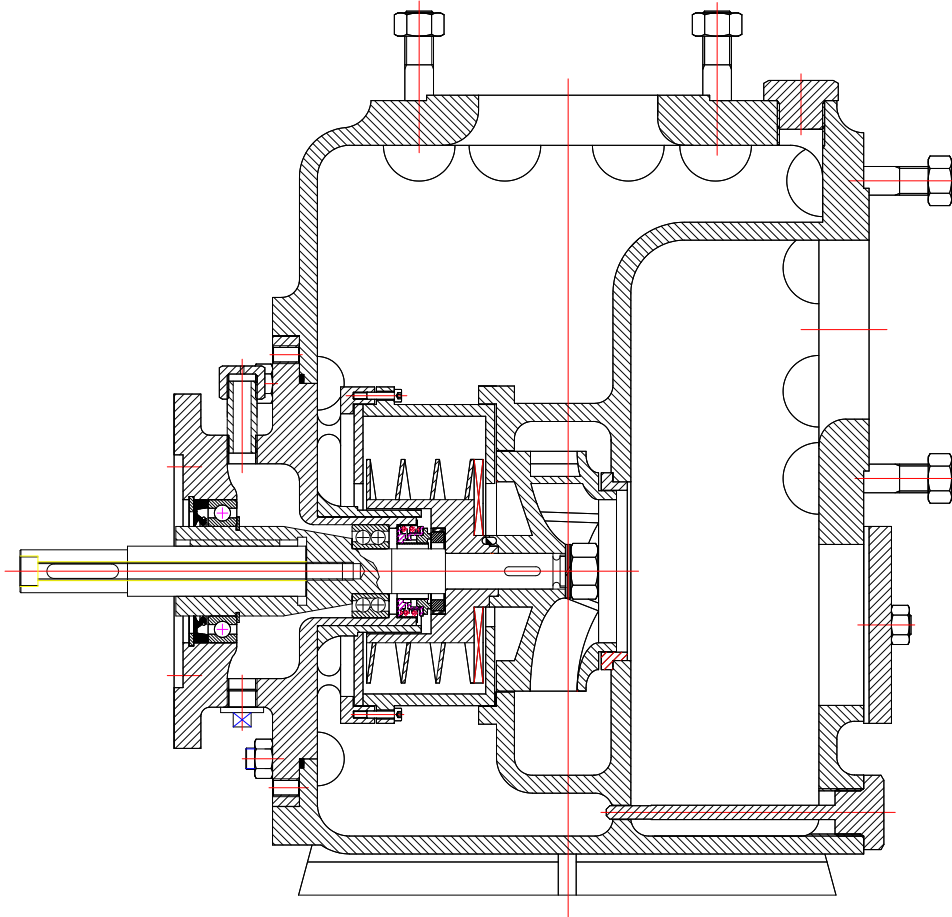

DESMI PUMPING TECHNOLOGY A/S
Tagholm 1 – DK-9400 Nørresundby – Denmark

Tel.: +45 96 32 81 11
Fax: +45 98 17 54 99
E-mail: desmi@desmi.com
Internet: www.desmi.com

Manual: T1449	Language: English	Revision: E (11/09)
------------------	----------------------	------------------------



Table of Contents:

1. PRODUCT DESCRIPTION	3
1.1 DELIVERY	3
2. TECHNICAL DATA	3
2.1 NAME PLATE	3
2.2 EXPLANATION OF THE TYPE NUMBER	3
2.3 TECHNICAL DESCRIPTION	4
3. INSTALLATION	4
3.1 MOUNTING/FASTENING	4
3.2 WIRING	6
4. TRANSPORT/ STORAGE	6
5. DISMANTLING SEE DRAWING NO. 490231	7
5.1 ACCESS TO IMPELLER AND ROTOR	7
5.2 DISMANTLING IMPELLER AND ROTOR	7
5.3 DISMANTLING SHAFT SEAL	7
5.4 DISMANTLING SEAT	7
5.5 DISMANTLING SHAFT WITH BEARINGS	7
5.6 INSPECTION	7
6. ASSEMBLING	7
6.1 FITTING SEALING RING IN PUMP CASING	7
6.2 FITTING SHAFT WITH BEARINGS	7
6.3 FITTING NYLON BUSHING	8
6.4 FITTING SHAFT SEAL	8
6.5 FITTING ROTOR	8
6.6 FITTING IMPELLER	8
6.7 FITTING BEARING BRACKET	8
6.8 SHAFT	8
7. FROST PROTECTION	8
8. DISMANTLING	9
9. START-UP	9
9.1 STARTING	9
10. SYSTEM BALANCING	9
11. INSPECTION AND MAINTENANCE	11
11.1 DRAINING THE PUMP	11
11.2 BEARINGS	11
12. REPAIRS	11
12.1 ORDERING SPARE PARTS	11
13. OPERATING DATA	11
14. EU DECLARATION OF CONFORMITY	12
15. INFORMATION RELEVANT FOR DISASSEMBLY OR DISPOSAL AT END-OF-LIFE	13
16. ASSEMBLY DRAWING	13
17. SPARE PARTS LIST	14
18. DIMENSIONAL SKETCH	15

1. PRODUCT DESCRIPTION

This operation and maintenance instruction applies to the DESMI self-priming centrifugal pump, type VAC-4001. The pump is available with DN100 on the suction and pressure flanges.

The VAC-4001 pump is a single-stage self-priming centrifugal pump with horizontal inlet and vertical outlet at the top. The pump is equipped with a rotor which enables it to efficiently evacuate air from the suction hose. Further the pump has stainless steel shaft and mechanical shaft seal.

The pump is suitable for pumping clean and polluted liquids with temperatures between 0 and 80°C.

Max. number of revolutions is 3600 RPM.

The pump is particularly suitable for bilge pumping and for use in piping systems where large amounts of air have to be evacuated.

The VAC-4001 pump is a quality product manufactured in accordance with ISO 9001.

1.1 DELIVERY

- Check on delivery that the shipment is complete and undamaged.
- Defects and damages, if any, to be reported to the carrier and the supplier immediately in order that a claim can be advanced.

2. TECHNICAL DATA

2.1 NAME PLATE

Manufacturer:
DESMI
DK-9400 Nørresundby
Phone +45 96328111
Fax +45 98175499
e-mail: desmi@desmi.com
<http://www.desmi.com>

TYPE: Pump type number
CODE NO.: Pump item No.
PUMP NO.: Pump No.
IMP.: Impeller diameter
WEEK/YEAR: Production week and year

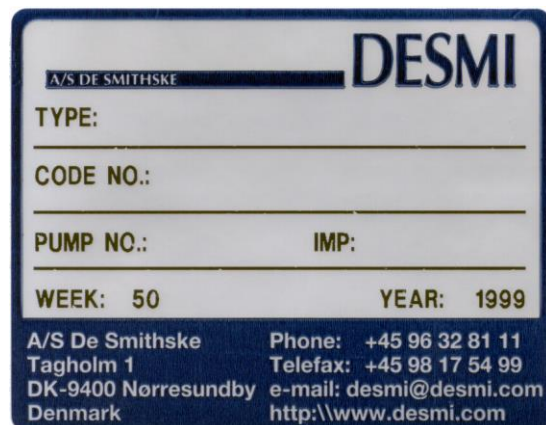

The pumps are manufactured in various material combinations which appear from the type number on the name plate.

2.2 EXPLANATION OF THE TYPE NUMBER

The VAC-4001 pump is provided with a name plate. The type number indicated on the name plate is built up as follows:

VAC-4001/M-R

M : The material combination of the pump.
R : The assembly combination of the pump.

M may be the following:

A : Standard. Casing: GG20. Impeller: Bronze. Rotor: Stainless steel
D : Casing: Rg5, Impeller: Bronze. Rotor: Stainless steel
E : Special alloy.

The pumps can be delivered in other material combinations, which are agreed with the supplier.

R may be the following:

01 : With electromagnetic clutch.
03 : With hydraulic motor.
04 : V-belt pulley and disengaging clutch.
07 : On base plate with petrol or diesel engine, or with electric motor.
09 : With bare shaft end.
10 : Special-tailored according to task.

Any use of the pump is to be evaluated on the basis of the materials used in the pump. In case of doubt, contact the supplier.

Pumps in material combinations A are primarily used for fresh water.
Pumps in material combination D are primarily used for seawater.

2.3 TECHNICAL DESCRIPTION

The noise level of the pump depends on the motor type supplied, as the noise from the pump can be calculated as the noise level of the motor + 2dB(A).

3. INSTALLATION

3.1 MOUNTING/FASTENING

The pump should be mounted and fastened on a solid base plate with a flat and horizontal surface to avoid distortion. The pump must be mounted in such a way that the shaft centerline is horizontal.

When mounting a V-belt pulley on the pump a bore H7 is recommended. To facilitate the mounting the hub in the V-belt pulley may be heated to about 100°C after which the V-belt pulley is easily lead over the shaft towards the shoulder. Alternatively, the V-belt pulley may be mounted with a TAPER LOCK bush.

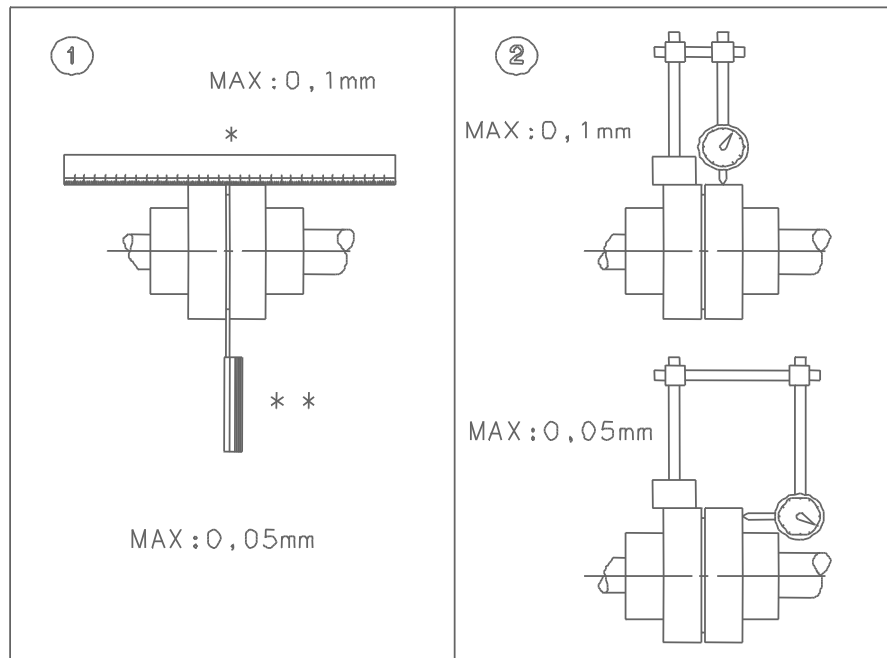

When dimensioning the V-belt pulley it is important to follow the rules of the DESMI nomograms for the pump size in question - contact DESMI.

Be careful when fitting the suction line to the pump so that it is absolutely tight, as even small leakages may impede the priming. When pumping polluted liquids a strainer is necessary. The strainer must be equipped with a sieve, the passage area of which is to be 3 x the area of the suction pipe. The mesh size is to be 1-3 mm smaller than the impeller gap of the pump in question.

In order to secure priming of the pump the pressure pipe is to be arranged so that water locks in the pipe are avoided.

If the pump is to be driven by a motor via a flexible coupling, motor and pump are to be placed on a common base plate. The following should be observed:

- Avoid distortion of the base plate.
- Avoid distortion in the piping system.
- Check that pump and motor are aligned correctly.

Two proposals for alignment are indicated above. The deviations mentioned cover a complete revolution of the coupling. The distance between the coupling halves is to be between 2 and 4 mm.



At installations pumping hot or very cold liquids, the operator must be aware that it is dangerous to touch the pump surface, and, consequently, he must take the necessary safety measures.

When connecting the pump and a prime mover the power transmission is to be equipped with a guard in accordance with the provisions of the COUNCIL DIRECTIVE.

3.2 WIRING



Wiring to be carried out by authorised skilled workmen according to the rules and regulations in force.

4. TRANSPORT/ STORAGE

The weights of the pumps are stated in the following table, and the pumps are to be lifted as shown below.

Pump	Weight [kg]
VAC-4001/A09	85
VAC-4001/A07 excl. electric motor	100
VAC-4001/A02	155

The pumps are to be stored in a dry place.

Before shipment the pump is to be fastened securely on pallets or the like.



The pump is to be lifted as shown here:

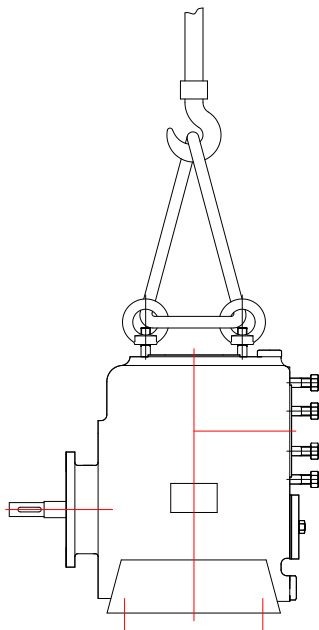

Screw lifting eyes into the pressure flange and mount lifting straps
The lifting straps must not bear against sharp edges and corners.

5. DISMANTLING SEE DRAWING NO. 490231

Before dismantling the pump, drain the bearing bracket of oil. Unscrew stud (31) and drain the oil into a bucket.

5.1 ACCESS TO IMPELLER AND ROTOR

Remove M12 nuts (1), which hold the bearing bracket (3) to the pump casing. Pull the bearing bracket (3) to remove the complete bearing bracket with rotor, impeller, bearings, and shaft. Remove the O-ring (12).

5.2 DISMANTLING IMPELLER AND ROTOR

Remove impeller nut (21) and washer (37). Pull off the impeller (19). Remove Allen screws (15), which hold the rotor housing (17) to the rear plate (14). Remove the rotor housing (17). Pull key (20) and rotor (16) off the shaft (5). Take care not to damage the seat which is mounted in the rotor. Remove rear plate (14) and nylon bushing (13).

5.3 DISMANTLING SHAFT SEAL

Pull the shaft seal off the shaft.

5.4 DISMANTLING SEAT

Pull the shaft seal seat carefully out of the recess of the rotor hub.

5.5 DISMANTLING SHAFT WITH BEARINGS

Before dismantling the shaft (5) with bearings (9-33), remove the lock ring (4) and the oil sealing ring (8). The shaft can now be pulled out of the bearing bracket allowing inspection of the bearings.

5.6 INSPECTION

When the pump has been dismantled, check the following parts for wear and damage:

- Sealing ring/impeller: Max. clearance 0.4-0.5 mm measured in radius
- Shaft seal: Check wear ring and seat for flatness and cracks.
Check the rubber parts for elasticity and scratches.
- Bearing: Replace in case of wear and noise
- Rotor: Check the rotor for damages
- Nylon bushing: Check for wear

6. ASSEMBLING

6.1 FITTING SEALING RING IN PUMP CASING

When fitted, the sealing ring (22) is to bear against the shoulder of the pump casing.

6.2 FITTING SHAFT WITH BEARINGS

Lead shaft with bearings into the bearing bracket. Fit oil sealing ring (8) and lock ring (4)

6.3 FITTING NYLON BUSHING

Press nylon bushing (13) into place in the bearing bracket hub.

6.4 FITTING SHAFT SEAL

Before fitting the seat, clean the recess in the rotor. When fitting the seat, remove the protective coating, if any, without scratching the lapped surface. Dip the outer rubber ring of the seat into soapy water. Now press the seat into place with the fingers and check that all parts are correctly imbedded. If it is necessary to use tools for assembling, protect the sliding surface of the seat to prevent it from being scratched or cut. Lubricate the inner diameter of the slide ring rubber bellows with soapy water and push it over the shaft. The use of a fitting bush as shown on the below assembly drawing is recommended to avoid that the rubber bellows is cut. Push the slide ring over the shaft with the hand. If the rubber bellows is tight, use a fitting tool and take care that the slide ring is not damaged.

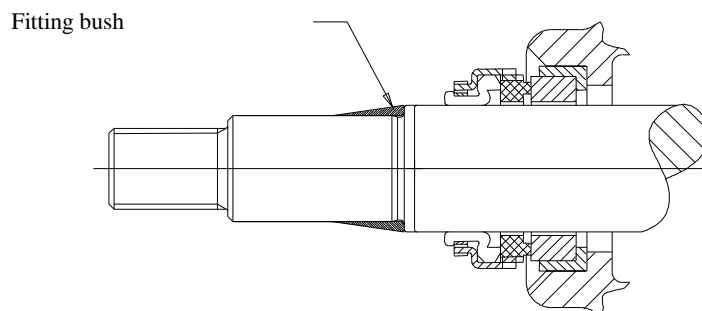

If the carbon ring is not fixed, it is important to check that it is fitted correctly, i.e. the chamfered/lapped side is to face the seat. The carbon ring can be held by a little grease. When using oil on the shaft, the bellows will settle and seat in about 15 minutes, and until then tightness should not be expected.

6.5 FITTING ROTOR

Fit locating pin (18) in the rotor hub. Place rear plate (14) in the recess of the nylon bushing and lead the rotor over the shaft and against the shoulder of the shaft. Mount the rotor housing (17) on the rear plate (14) by means of the Allen screws (15).

6.6 FITTING IMPELLER

Fit the sunk key (9) in the shaft and lead the impeller towards the shoulder of the shaft. Take care that the pin is placed in the hole of the impeller hub. Secure the impeller with a washer (37) and a nut (21).

6.7 FITTING BEARING BRACKET

Place the O-ring (12) that seals between pump casing and bearing bracket on the bearing bracket where it can be held with a little silicone grease. Lead bearing bracket into place and fasten with nuts (1). Mount drain plug (7) and fill bearing bracket with oil (SAE 15W40) until half the shaft is covered.

6.8 SHAFT

When the pump has been assembled, check that the shaft rotates freely.

7. FROST PROTECTION

Pumps which are not in operation during frost periods are to be drained to avoid frost damage. Remove the drain bolt (32) at the bottom to empty the pump. Alternatively, it is possible to use anti-freeze liquids in normal constructions.

8. DISMANTLING



Before dismantling the pump make sure that it has stopped. Empty the pump of liquid before it is dismantled from the piping system. If the pump has been pumping dangerous liquids you are to be aware of this and take the necessary safety measures. If the pump has been pumping hot liquids, take great care that it is drained before it is removed from the piping system. If cold or very hot liquids have been pumped, the operator must be aware that it is dangerous to touch the pump surface and he must, consequently, take the necessary safety measures.

9. START-UP



A self-priming centrifugal pump will not function until the pump casing has been filled with liquid.

The liquid also serves as coolant for the shaft seal. In order to protect the shaft seal the pump must not run dry.

WARNING

For safety reasons the pump is only allowed to operate against closed discharge valve for a short time (max. 5 minutes and at a max. temperature of 80°C for standard pumps). Otherwise there is a risk of damage to the pump and, at worst, of a steam explosion. If the pump is not monitored, the installation of a safety device is recommended.

9.1 STARTING

Before starting the pump check that

- the shaft rotates freely without noise
- the pump casing is filled with liquid.

Start the pump for a moment to check direction of rotation. If the direction is correct (i.e. in the direction of the arrow), the pump may be started.

10. SYSTEM BALANCING

It is often difficult to calculate a manometric delivery head in advance. It is, however, decisively important to the quantity of liquid delivered. A considerably smaller delivery head than expected will increase the quantity of liquid delivered, causing increased power consumption and perhaps cavitation in pump and piping. In the pump the impeller may show signs of heavy erosion caused by cavitation (corrosion) which may at times render an impeller unfit for use in a very short time. Not unusually do similar erosions occur in pipe bends and valves elsewhere in the piping system. Therefore, after start-up, it is necessary to check either the quantity of liquid delivered or the power consumption of the pump e.g. by measuring the current intensity of the connected motor. Together with a reading of the differential pressure the quantity of water delivered can be determined against the characteristics of the pump.

In cases where the liquid flow of the pump has to be reduced a valve in the piping system is the most common solution. This valve **always** has to be placed on the suction side of the pump - never on the delivery side.

Should the pump not function as intended, please proceed according to the fault-finding list. Bear in mind, though, that the pump was carefully checked and tested at the factory and that the majority of faults stem from the piping system.

FAULT	CAUSE	REMEDY
The pump does not prime	<ol style="list-style-type: none"> 1. The pump is not filled with liquid 2. Leaking non-return valve in pump 3. Wrong direction of rotation 4. Air is drawn in because of too little liquid or leaking suction line 5. Liquid lock in outlet line 6. Temperature of liquid too high 7. Air cannot escape on pressure side 	<p>Fill pump casing with liquid</p> <p>Remove foreign body in valve/Remove any coating on mating faces</p> <p>Change direction of rotation</p> <p>Lower suction pipe/ Tighten suction line</p> <p>Change the pressure line so that the air can pass out freely</p> <p>Replace liquid in pump casing/Wrong dimensioning/Contact DESMI</p> <p>Ventilate the system</p>
The pump has no or too low capacity	<ol style="list-style-type: none"> 1. Wrong direction of rotation 2. Piping system choked 3. The pump is choked 4. Suction line leaks Pump takes air 5. Suction lift too high 6. Pump and piping system wrongly dimensioned 	<p>Change direction of rotation to clockwise when viewed from shaft end (the direction of the arrow)</p> <p>Clean or replace</p> <p>Clean the pump</p> <p>Find the leakage/repair the fault, non-return valve not submerged</p> <p>Check data sheet Q/H curve and NPSH or contact DESMI</p> <p>As 5</p>
The pump uses too much power	<ol style="list-style-type: none"> 1. Counter-pressure too low 2. The liquid is heavier than water 3. Foreign body in pump 4. Electric motor is running on 2 phases 	<p>Insert orifice plate or check valve/Contact DESMI</p> <p>Contact DESMI</p> <p>Dismantle the pump, remove the cause</p> <p>Check fuses, cable connection, and cable</p>
The pump makes noise	<ol style="list-style-type: none"> 1. Cavitation in pump 	<p>Suction lift too high/</p> <p>Suction line wrongly dimensioned/Liquid temperature too high</p>

11. INSPECTION AND MAINTENANCE

Inspect the shaft seal for leaks at regular intervals.

This is done by checking the oil inside the bearing bracket. If the shaft seal is leaking the oil becomes white.

- Before inspection of a pump without guard check that the pump cannot bestarted unintentionally.
- The system is to be without pressure and drained of liquid.
- The repairman must be familiar with the type of liquid that has been pumped as well as the safety measures he is to take when handling the liquid.

11.1 DRAINING THE PUMP

When the piping system has been drained, note that there is still liquid in the pump. Remove the liquid by dismantling the drain bolt (32) at the bottom of the pump.

11.2 BEARINGS

The pump is equipped with deep groove ball bearings with a nominal life of 25,000 working hours when direct coupled to electric motor, whereas the nominal life with overhanging V-belt drive is about 10,000 working hours. The bearings are oil lubricated and they only require that the oil level in the bearing bracket is correct. However, they should be replaced in case of noise or bearing wear. In connection with a leaking shaft seal where water has penetrated the bearings, inspect these for damages and replace is necessary.

12. REPAIRS

12.1 ORDERING SPARE PARTS

When ordering spare parts please always state pump type and pump no. (available from the name plate of the pump). See also spare parts drawing with item nos.

13. OPERATING DATA

The following working pressures are allowed

PUMP	VAC-4001
Pressure [mWC]	35

(10.2 mWC = 1 bar)

The above-mentioned max. working pressure is **NOT** valid for pumps approved by a classification society. Pumps approved by classification societies have been pressure tested according to the requirements of these societies, i.e. a test pressure of 1.5 x the permissible working pressure. The test pressure is stated in the test certificate and stamped into the discharge flange of the pump.

14. EU DECLARATION OF CONFORMITY

DESMI PUMPING TECHNOLOGY A/S, hereby declare that our pumps of the type VAC-4001 are manufactured in conformity with the following essential safety and health requirements in the COUNCIL DIRECTIVE 2006/42/EC on machines, Annex 1.

The following harmonized standards have been used:

EN/ISO 13857:2008	Safety of machinery. Safety distances to prevent danger zones being reached by the upper limbs
EN 809:1998 + A1:2009	Pumps and pump units for liquids – Common safety requirements
EN12162:2001+A1:2009	Liquid pumps – Safety requirements – Procedure for hydrostatic testing
EN 60204-1:2006/A1:2009	Safety of machinery – Electrical equipment of machines (item 4, General requirements)

Pumps delivered by us connected with prime movers are CE-marked and comply with the above requirements.

Pumps delivered by us without prime movers (as partly completed machinery) must only be used when the prime mover and the connection between prime mover and pump comply with the above requirements.

Nørresundby, Marts 05 2019



Henrik Mørkholt Sørensen
Managing Director

DESMI Pumping Technology A/S
Tagholm 1
9400 Nørresundby

15. INFORMATION RELEVANT FOR DISASSEMBLY OR DISPOSAL AT END-OF-LIFE

No damage materials are used in DESMI pumps – please refer to DESMI Green Passport (can be sent on request – contact a DESMI sales office) – i.e. common recycling companies can handle the disposal at end-of-life. Alternatively the pump and motor can be returned to DESMI at end-of-life for safe recycling.

16. ASSEMBLY DRAWING

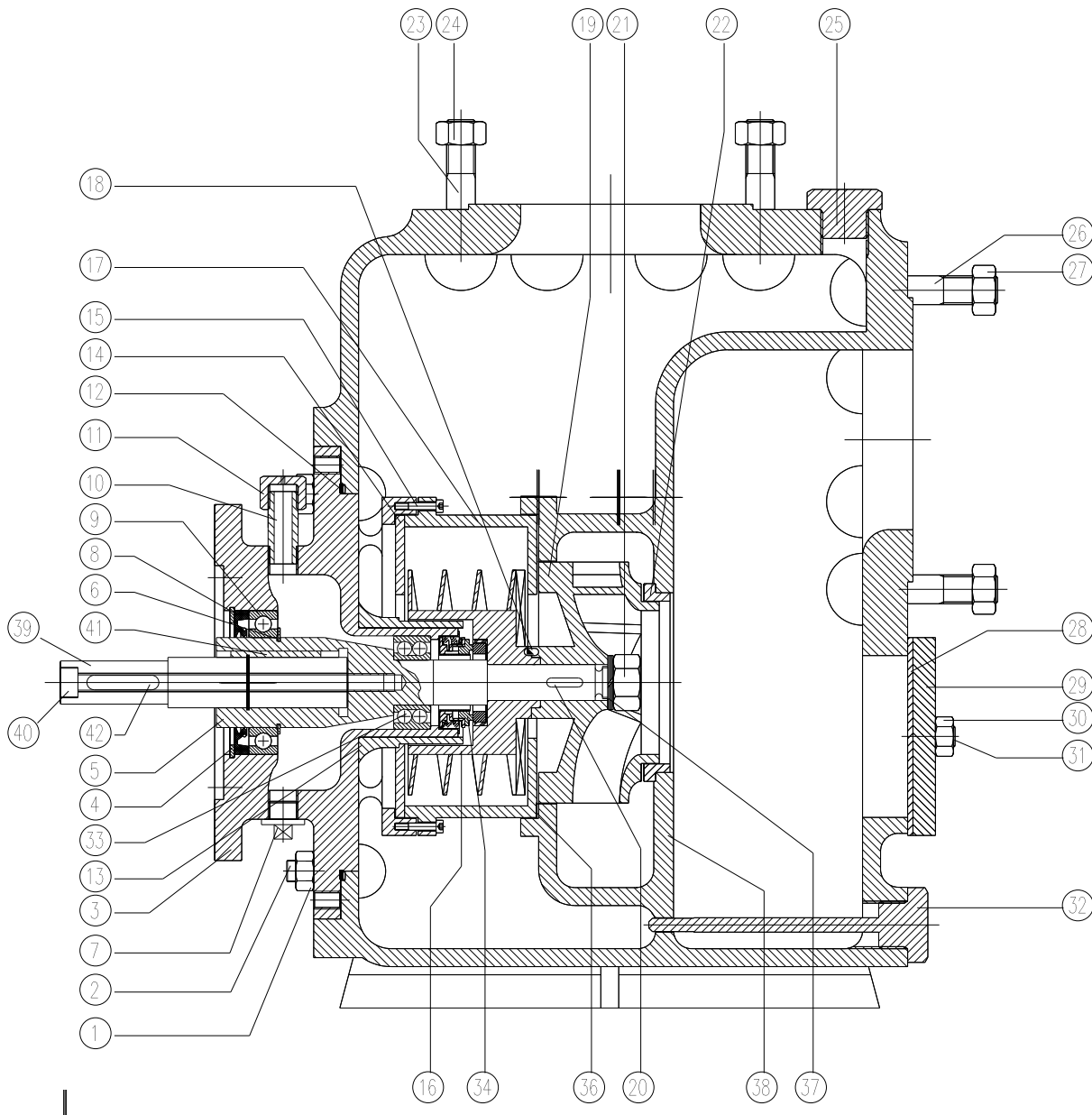

17. SPARE PARTS LIST

Pos. No.	Description	Qty.	Item No.
01	Nut M12	6	704063
02	Stud M12x25	6	708883
03	Bearing bracket	1	590750
04	Lock ring	1	701112
05	Shaft	1	590770
06	Lock ring	1	701125
07	Drain plug 3/8" BSP	1	2037505
08	Oil sealing ring	1	701292
09	Ball bearing 6010-2RS1	1	703381
10	Nipple 3/8"x40	1	710938
11	End plug 3/8" RG	1	190530
12	O-ring	1	710945
13	Nylon bushing	1	590760
14	Rear plate for rotor housing	1	190531
15	Allen screw M5x30	4	710940
16	Rotor	1	190532
17	Rotor housing	1	190533
18	Locating pin \varnothing 4x18	1	706284
19	Impeller	1	590730
20	Key 5x5x20	1	700012
21	Impeller nut M18x1.5	1	710943
22	Wear ring	1	590720
23	Stud M16x40 A4	8	710935
24	Nut M16 A4	8	704037
25	Filling plug 3/4"	1	706970
26	Stud M16x40 A4	8	710935
27	Nut M16 A4	8	704037
28	Gasket for inspection cover	1	190528
29	Inspection cover	1	190529
30	Nyloc nut M12	2	703232
31	Stud M12x25 A4	2	708883
32	Drain bolt 3/4"	1	190527
33	Ball bearing 5205	1	710937
34	Shaft seal	1	710936
36	O-ring for rotor housing	1	710946
37	Lock washer M18	1	710944
38	Pump casing	1	590710
39	Shaft end	1	590780
40	Allen screw M10x170 A4	1	710947
41	Key 7x8x50	1	706834
42	Key 7x8x40	1	700021

18. DIMENSIONAL SKETCH

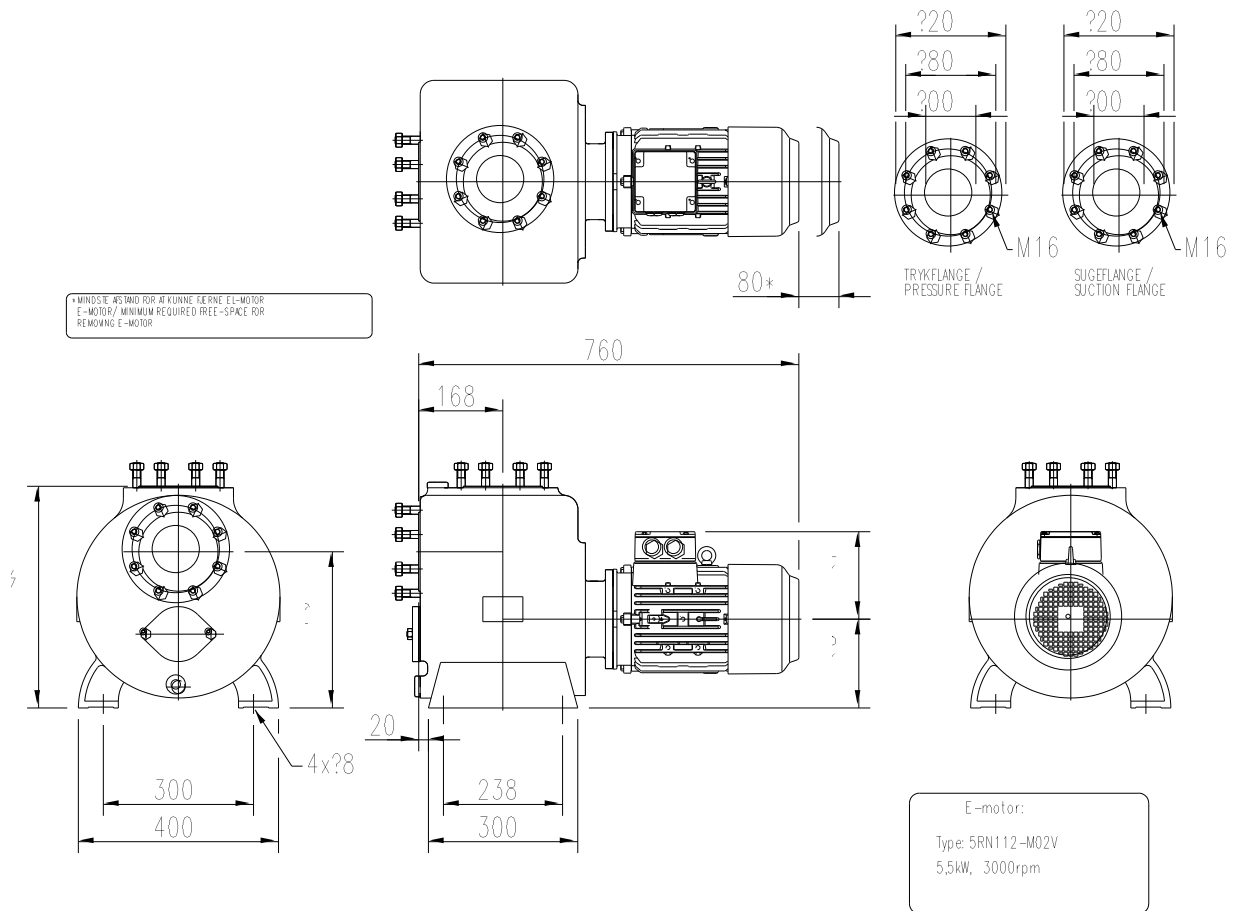

L