

Ø0.56 HOLES IN MOUNTING STRUCTURE REQUIRED.

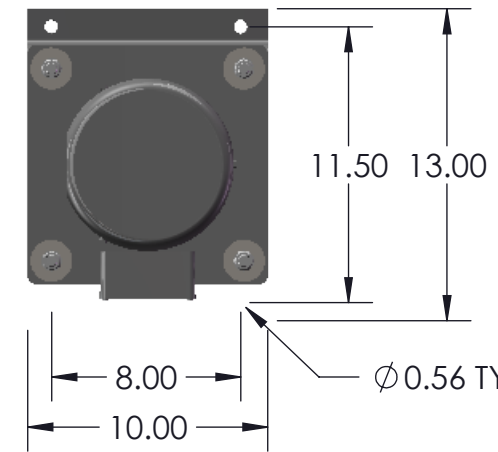

OPTIONAL ANGLE RISER MOUNTING

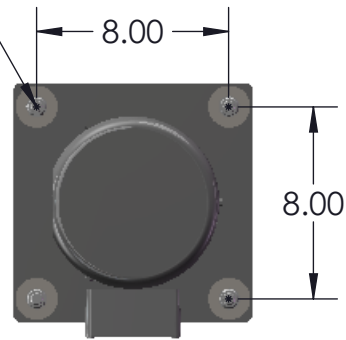
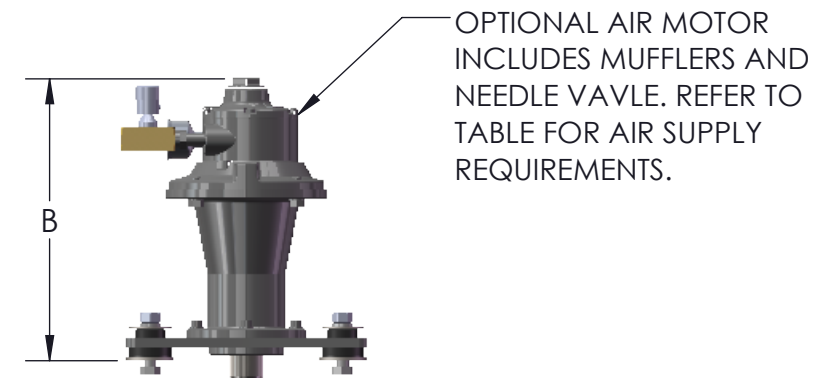
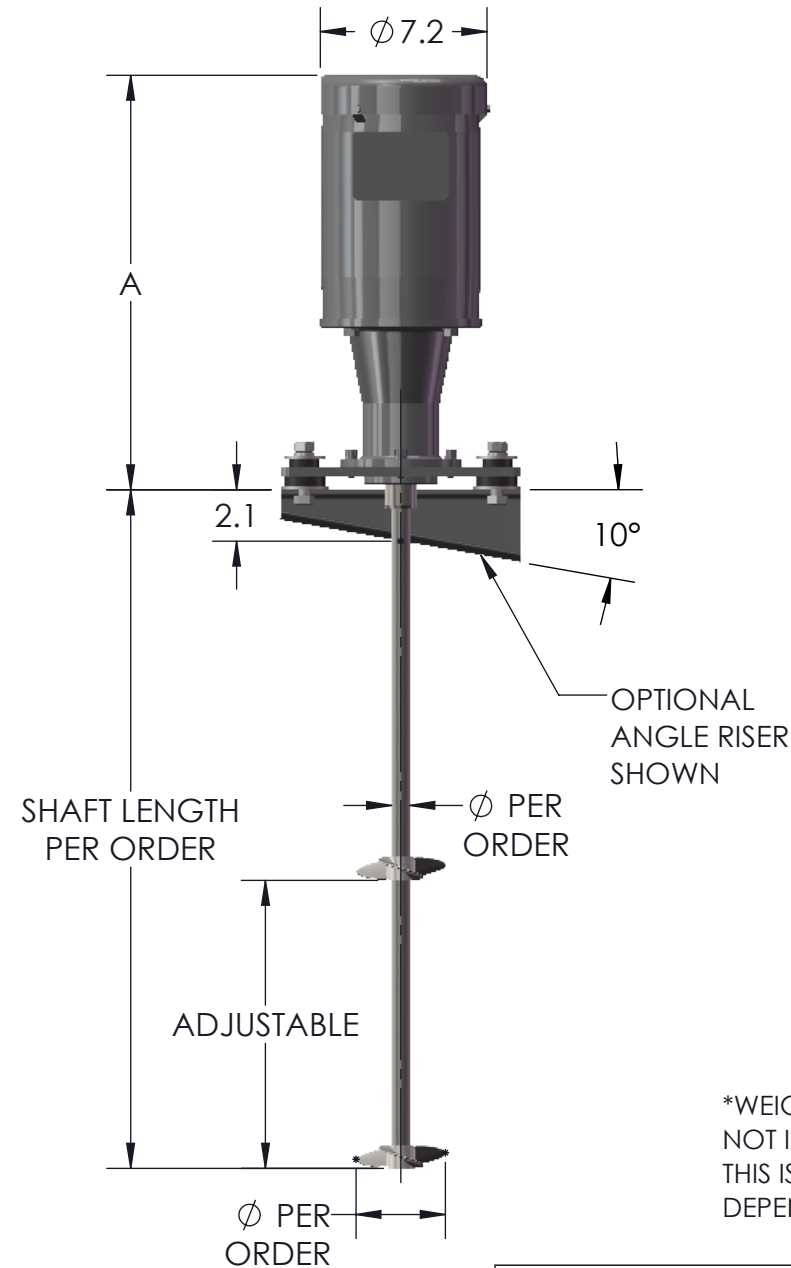

OPTIONAL AIR MOTOR INCLUDES MUFFLERS AND NEEDLE VALVE. REFER TO TABLE FOR AIR SUPPLY REQUIREMENTS.

ALL DIMENSIONS ARE IN INCHES.

AIR MOTOR HORSEPOWER AND AIR CONSUMPTION		
HORSEPOWER	1/2	1
CFM AIR CONSUMPTION	23	40
AT PSI	40	80
INLET SIZE (NPT)	3/8	3/8

MIXER MODEL	DIMENSION		
	A	B	*WGT
MDF33	16.9	10.9	45
MDF50	17.8	10.9	53
MDF75	18.2	10.9	56

*WEIGHT IS IN POUNDS WITH ELECTRIC MOTOR. DOES NOT INCLUDE SHAFT OR IMPELLER(S) OR AIR MOTOR. THIS IS A MAXIMUM WEIGHT. ACTUAL WEIGHT DEPENDS ON SPECIFIC MOTOR TYPE AND SELECTION.

FOR REFERENCE ONLY

* ALL DIMENSIONS AND WEIGHTS ARE FOR REFERENCE ONLY UNLESS THE DRAWING IS CERTIFIED.

* ALL EQUIPMENT DESIGN AND APPLICATION DATA SHOWN HEREIN IS CONFIDENTIAL AND THE PROPERTY OF BRAWN MIXER. NO USE OR DISCLOSURE THEREOF MAY BE MADE WITHOUT OUR WRITTEN PERMISSION.



12838 STAINLESS DR
HOLLAND, MI 49424
PH: 616-399-5600
FAX: 616-399-3084

MIXER MODEL
MD33 THRU 75
DIRECT DRIVE
DIMENSION AND ASSEMBLY DRAWING

DRAWN BY:BSB DATE:10/8/2018 © 2018
APPROVED BY: DATE:

DWG. NO. **B- TK0132** REV.