

**NOTES:**

1. BASIC WEIGHT DOES NOT INCLUDE SHAFT, IMPELLERS OR MOTOR.
2. ALL DIMENSIONS ARE IN INCHES AND ARE FOR REFERENCE ONLY UNLESS CERTIFIED.
3. OVERALL HEIGHT DIMENSION (A) MAY VARY DEPENDING ON SEAL OPTION SELECTED.
4. AF3 3 BLADE HYDROFOIL IMPELLERS SHOWN. OTHER IMPELLERS AVAILABLE UPON REQUEST OR PER APPLICATION.
5. LOW PRESSURE STUFFING BOX SHOWN. SINGLE AND DOUBLE MECHANICAL SEAL ARE ALSO AVAILABLE.

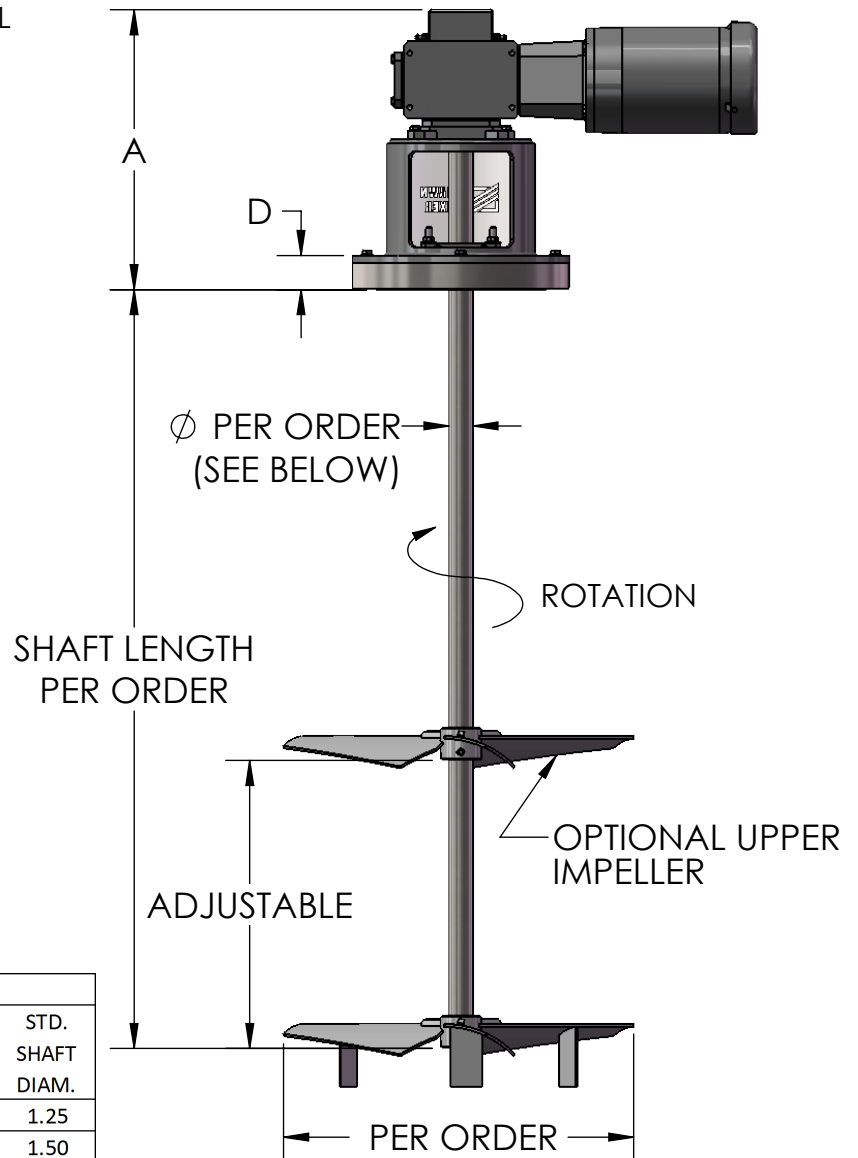
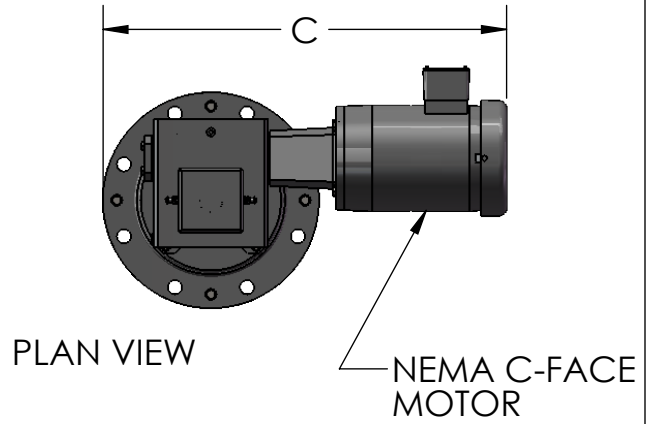

**\*FOR REFERENCE ONLY\***

| BWG DIMENSIONS |      |      |      |      |                  |                  |                  |
|----------------|------|------|------|------|------------------|------------------|------------------|
| CASE SIZE      | A    | B    | C    | D    | STD. ANSI FLANGE | BASIC WGT. (LBS) | STD. SHAFT DIAM. |
| 11             | 20.5 | 16.7 | 23.5 | 1.50 | 6" - 150lbs.     | 120              | 1.25             |
| 12             | 21.7 | 18.3 | 26.3 | 1.50 | 8" - 150lbs.     | 240              | 1.50             |
| 13             | 23.5 | 19.1 | 27.1 | 1.50 | 8" - 150lbs.     | 270              | 2.00             |
| 14             | 25.0 | 20.5 | 28.5 | 1.50 | 10" - 150lbs.    | 360              | 2.50             |
| 15             | 27.0 | 22.0 | 30.0 | 1.50 | 10" - 150lbs.    | 470              | 3.00             |

\* ALL DIMENSIONS AND WEIGHTS ARE FOR REFERENCE ONLY UNLESS THE DRAWING IS CERTIFIED.

\* ALL EQUIPMENT DESIGN AND APPLICATION DATA SHOWN HEREIN IS CONFIDENTIAL AND THE PROPERTY OF BRAUN MIXER. NO USE OR DISCLOSURE THEREOF MAY BE MADE WITHOUT OUR WRITTEN PERMISSION.



12838 Stainless Drive  
Holland, MI 49424

PH: 616-399-5600  
FAX: 616-399-3084

**MIXER MODEL  
BWG PEDESTAL**

SEALED TANK FLANGE MOUNT MIXER  
DIMENSION AND ASSEMBLY DRAWING

DRAWN BY: BSB      DATE: 10/9/2018      © 2018

APPROVED BY:      DATE:

DWG. NO. **A- TK0039**      REV.