

SPLIT CASE PUMPS

Model
411, 413, 412,
481 AND 483

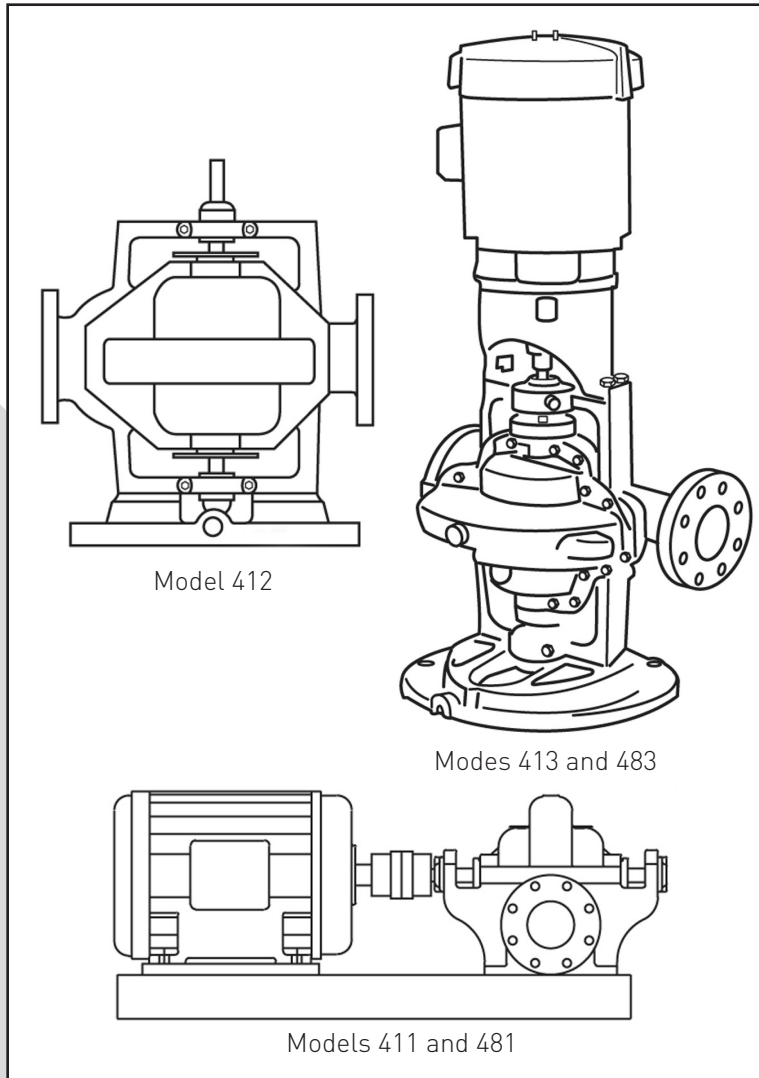

ENGLISH: PAGES 2-12

INSTRUCTION AND REPAIR MANUAL

NOTE! To the installer: Please make sure you provide this manual to the owner of the equipment or to the responsible party who maintains the system.



CALIFORNIA PROPOSITION 65 WARNING:

▲ WARNING This product and related accessories contain chemicals known to the State of California to cause cancer, birth defects or other reproductive harm.

NOTE

This repair manual is applicable to pump Models 411 & 481, 412, 413, & 483. All photos illustrate Model 412.

ATTENTION: SAFETY WARNINGS:

Read and understand all warnings before installation or servicing pump.

OPERATIONAL LIMITS: *

Maximum Operating Pressure: 175 psi at Temperatures to 150°F (65.6°C)
Maximum Operating Temperature: 225°F (107°C)

SERVICE

Your Aurora pump requires no maintenance other than periodic inspection, lubrication and occasional cleaning. The intent of inspection is to prevent breakdown, thus obtaining optimum service life.

LUBRICATION (BALL BEARINGS)

Regreasable bearings will require periodic lubrication and this can be accomplished by using the zerk or lubrication fitting at each bearing. Lubricate the bearings at regular intervals using high quality grease. The initial bearing lubrication at Aurora is Chevron SRI Grease NLGI 2 (polyurea thickener) (Pentair Part Number 384-0002-639). Before lubricating the bearings, thoroughly flushing the old grease with the new grease is required. We recommend Chevron SRI Grease NLGI 2 (polyurea thickener) for follow-up relubrication after the flushing. Most major brands of Grade No. 2 ball bearing grease are satisfactory for pump operation in both wet and dry applications.

CAUTION

Be aware that mixing of different brands or blends of grease should be avoided due to possible incompatibilities that could damage the bearings. A thorough flushing of the old grease with the new grease is required to minimize this potential incompatibility. Avoid using the following: (1) grease of vegetable or animal base that can develop acids or (2) grease containing rosin, graphite, talc or other impurities. Under no circumstances should grease be reused.

CAUTION

Over lubrication should be avoided as it may result in overheating and possible bearing failure. Under normal application, adequate lubrication is assured if the amount of grease is maintained at 1/3 to 1/2 the capacity of the bearing and adjacent space surrounding the bearing.

In dry locations, each bearing will need lubrication at least every 4,000 hours of running time or every 6 to 12 months, whichever is more frequent. In wet locations the bearings will need lubrication at least after every 2,000 hours of running time or every 4 to 6 months, whichever is more frequent. A unit is considered to be

installed in a wet location if the pump and motor are exposed to dripping water, to the weather, or to heavy condensation such as found in unheated and poorly ventilated underground locations.

At times it may be necessary to clean the bearings due to accumulated dirt or deteriorated lubricants. This can be accomplished by flushing the bearing with light oil heated to 180° to 200° F. While rotating it on a spindle, wipe the bearing housing with a clean rag soaked in a cleaning solvent and flush all surfaces.

Dry bearing thoroughly before relubrication. Compressed air can be used to speed drying, but care should be taken not to let bearings rotate while being dried.

CAUTION

Use normal fire caution procedures when using any petroleum cleaner.

Model 411 pumps are available with two options for lubricating the shaft bearings:

- 1. Regreasable
- 2. Oil Lubrication

Oil lubricated bearings are optional on some Model 411 series pumps. A fixed oil level is maintained within the power frame of an oiler which allows visual indications of reserve oil.

At initial installation and before starting a unit that has been shut down for repairs or for any extended length of time, run enough 10W-30 weight motor oil through the oiler to maintain a constant oil level to insure that the bearing will never be without an oil supply. Oil will have to be added at intervals to maintain a constant level in the oiler. This interval can only be determined by experience.

Under working conditions, oil will breakdown and need to be replaced at regular intervals. The length of these intervals will depend on many factors. Under normal operation, in clean and dry locations, the oil should be changed about once a year.

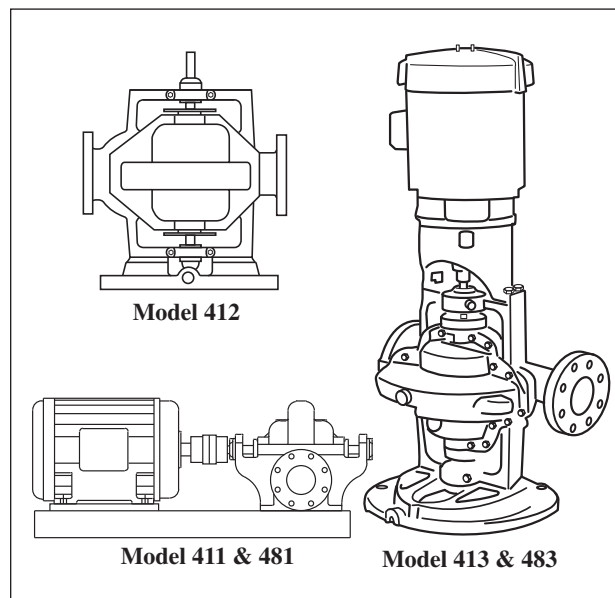

A. Complete pump assemblies.

MODELS 411 & 481, 412, 413 & 483

However, when the pump is exposed to dirt contamination, high temperatures (200F. or above) or a wet location, the oil may have to be changed every 2 or 3 months.

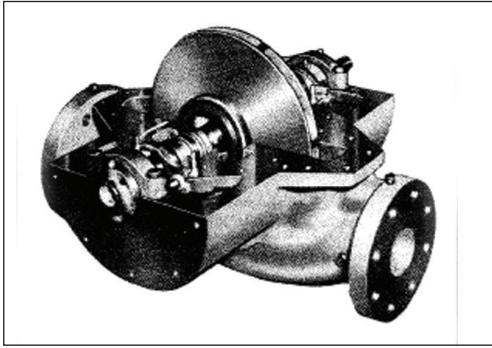

B. Casing half removed.

The motor that drives your Aurora pump may or may not require lubrication. Consult the manufacturer's recommendations for proper maintenance instructions.

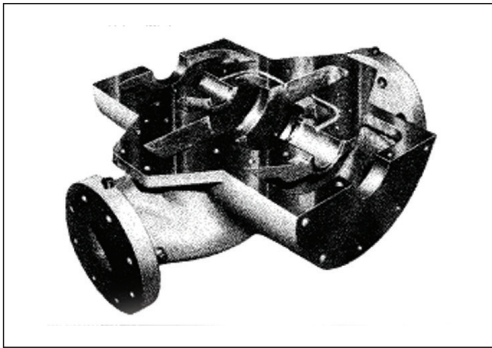

C. Rotating element removed from casing half.

REPAIRS

The pump may be disassembled using the illustrations and text provided. Although complete disassembly is covered, it will seldom be necessary to completely disassemble your Aurora Pump.

The illustrations accompanying the disassembly instructions show the pump at various stages of disassembly. The illustrations are intended to aid in the correct identification of the parts mentioned in the text.

Inspect removed parts at disassembly to determine their reusability. Cracked castings should never be reused. All packing and gaskets should be replaced with new ones at reassembly simply as a matter of economy; they are much less expensive to replace routinely than to replace as the need accrues. In general it is economical to return to the manufacturer for repair only the motor and motor controller.

DISASSEMBLY OF THE PUMP - Disassemble only what is needed to make repairs or accomplish inspection. Proceed to disassemble the pump as follows: (see figure 4 for Model 411 & 481, Figure 5 for Model 412 and Figure 6 for Model 413 & 483.

1. Break the electrical connections to motor or take other steps needed to prevent drive unit from being unintentionally energized during disassembly.

2. Close such valves or flow-control devices necessary to make certain flow of liquid will no take place during disassembly.

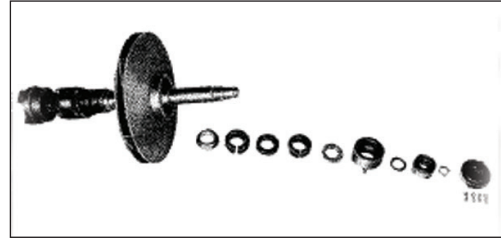

D. Outboard rotating element components removed illustrating disassembly order.

NOTE

Discharge and suction piping need not be disturbed unless complete pump assembly is to be removed.

3. Drain liquid from pump by removing plugs (1 and 2). Disconnect any flushing, cooling, by-pass lines that are connected to parts that will be removed.

4. Loosen and remove capscrews (6) securing casing half (8) to remainder of pump assembly.

NOTE

If pump being disassembled is size 4x5x11 or larger, remove capscrews (7) also before attempting to separate casing halves. If possible drain and/or flush pump to remove any corrosive or toxic liquid before attempting further disassembly. Many units will not have drain taps.

5. Make certain all securing capscrews are removed, then carefully remove casing half (8) using hoist or crane with a sling attached around cast hooks on the casing and under the casing.

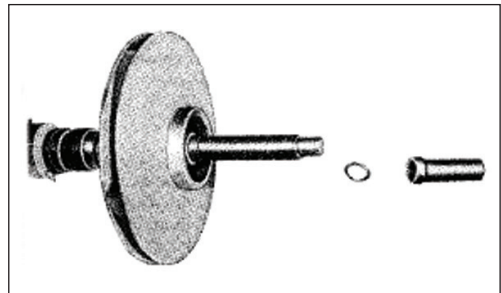

E. Sleeve and thrust washer removed.

CAUTION

Use extreme care when casing comes loose that it does not drop out of sling, as this would cause extensive damage to other components of pump.

6. Remove gasket (9) and scrape mating surface of casing halves to remove pieces of gasket which have adhered in separation. Take care not to scratch or mar mating surface.

7. On Model 411, 481 and 413, 483 loosen flexible coupling and slide the halves apart. On Model 412 pumps remove flexible shafting.

8. Remove four capscrews (25) SECURING TWO BEARING CAPS (26). Lift off bearing caps (26) and pins (27). Mark caps to insure correct replacement and orientation on the respective bearing arms.

9. Loosen and remove four nuts (18), washers (19), and gland clamps (20) securing split halves of two packing glands (21). Remove four swing bolts (22).

10. Assuming that further work is required on shaft and impeller assembly use properly secured rope sling and hoist or crane as required to lift it from casing half (69) and place it on a suitable bench or work surface.

CAUTION

Take care not to dent or damage impeller and/or other parts. Use of a supporting cradle or work stand is recommended.

NOTE

Disassembly procedure from this point covers pumps having standard packing. If pump has mechanical seals, refer to specific instructions.

11. Remove and discard rings of packing (23). Replacement with new packing is recommended whenever pump is disassembled.

12. Slip off flexible coupling half or spacer coupling and remove key (24). If preferred, the key may be removed by carefully tapping it from outer end with a brass drift or similar non-marring tool, using a small hammer.

13. Remove two casing wearing rings (28)

14. Remove zerks (10) and pipe plugs (12) from cartridge caps (32 and 42).

15. Loosen and remove four capscrews (31) from cartridge cap (32). The outboard shaft end protector (29) may be removed from its recess in the outboard cartridge cap if necessary. Remove retainer ring (35) with a pair of trauarc pliers. Also remove gasket (34).

NOTE

If the unit has a tandern shaft, protector (29) is not used.

16. Outboard bearing (38) is press fitted into shaft (65). To remove it, place a puller on bearing cartridge (36) and pull cartridge, grease seal (37) and bearing from shaft. The grease seal can be pressed from the bearing cartridge if it needs replacing, then slide slinger (39), lantern ring (52) and bushing (56) off shaft (65).

On 6B, 7A and 7 Power Frames remove snap ring (35A) on inboard side of bearing. Then slide slinger (39), lantern ring (52), and bushing (56) off shaft.

17. Removal of inboard bearing is basically the same as for outboard bearing. Remove capscrews (41) and slide slinger (40), cartridge cap (42), grease seal (43) and gasket (44) off shaft.

18. Pull or press off bearing cartridge (45), grease seal (46) and bearing (47). Remove slinger (48), lantern ring (52) and bushing (56) from shaft.

19. If pump has right hand rotation, unscrew and remove outboard sleeve (57) first. (See Note 1) Remove o-ring (58). If pump has left hand rotation, unscrew and remove inboard sleeve (64) first. (See Note 1) Remove o-ring (62).

NOTE 1

For Power Series 7A pumps, the sleeve collar (79) must be removed before the sleeve (57, 64). Loosen setscrews (72) and use an adjustable head spanner wrench to carefully unthread the collar (79). The sleeve (57, 64) may then be directly pulled from the shaft.

20. Key (63) holds impeller (59) and either sleeve (64) if pump is right hand or sleeve (57) for left hand pump. These parts can be removed by pulling impeller from shaft (65) and removing key (63) from its position in keyway and sleeve. Unscrew and remove remaining sleeve and gasket.

21. Disassemble wearing ring (61) (optional) from impeller (59) only if necessary. On power frames 5, 6B and 7, remove setscrews (78). Apply a puller and gradually withdraw wear ing rings (61) from impeller (59). Wearing rings may have to be cut or trimmed off the impeller. If a lathe is used to trim rings off, use care not to clamp impeller too tightly and cause distortion. Also use care not to remove any metal from impeller.

22. Remove locking and locating pins (66, 67, and 68) from casing half (69) only if replacement is necessary.

23. Nameplate (71) and its securing screws (70) should only be removed if replacement is necessary.

24. For model 413 & 483 pumps, unscrew capscrews (75) to remove motor and motor bracket (74) from casing half (69). The motor can be separated from motor bracket by removing capscrews (73).

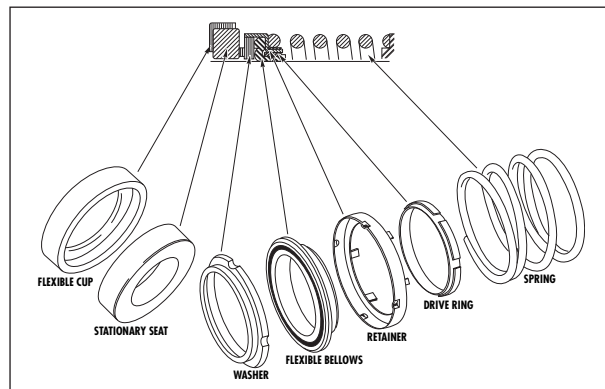

Figure 1. Mechanical Seal

25. If complete removal of pump is required, disconnect the suction and discharging piping from casing half (69). Remove nuts from foundation bolts and lift pump casing half (69) and base (77) out. When the casing half and base are moved away from the piping, lay them on their side, so that, by removing capscrews (76), the base can be separated from casing half (69).

MODELS 411 & 481, 412, 413 & 483

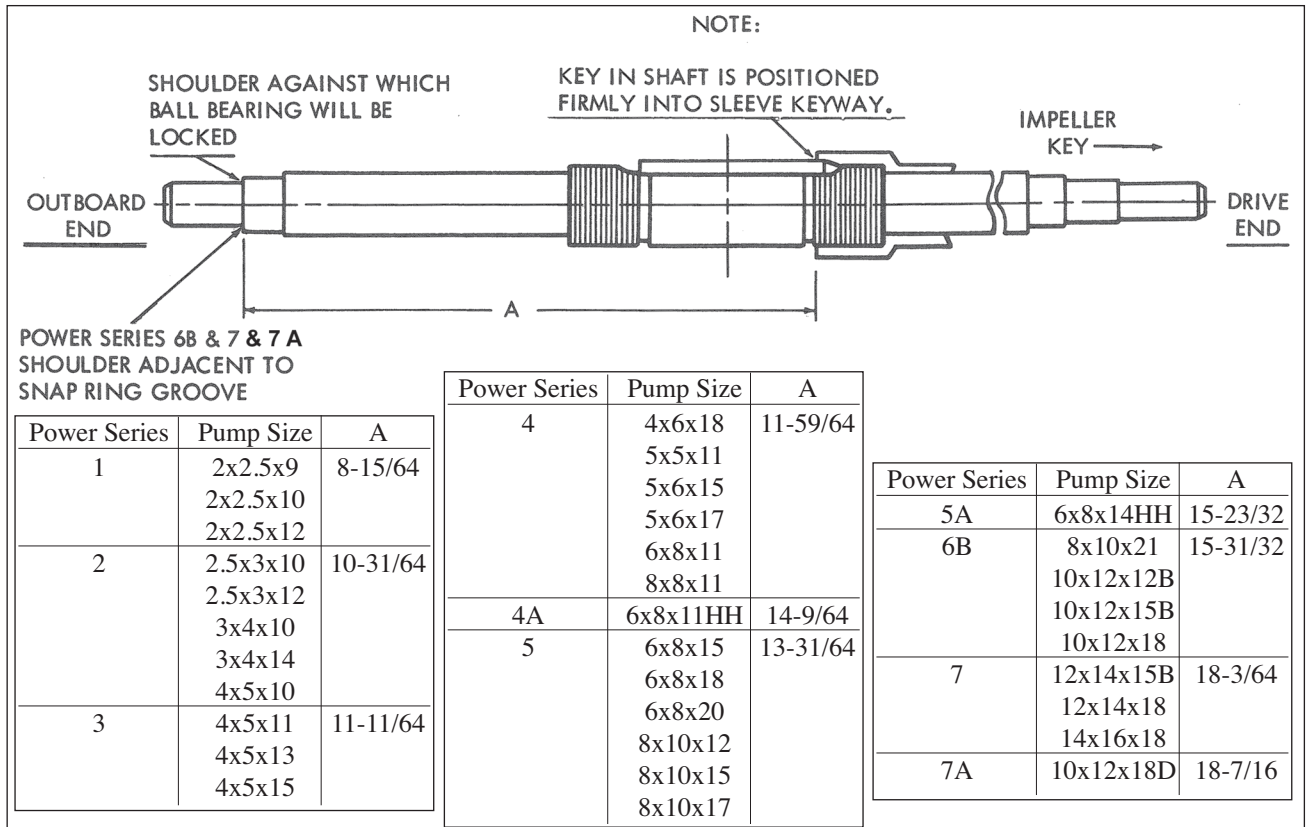

Figure 2. Locating Shaft Sleeve on Shaft, Right Hand Rotation

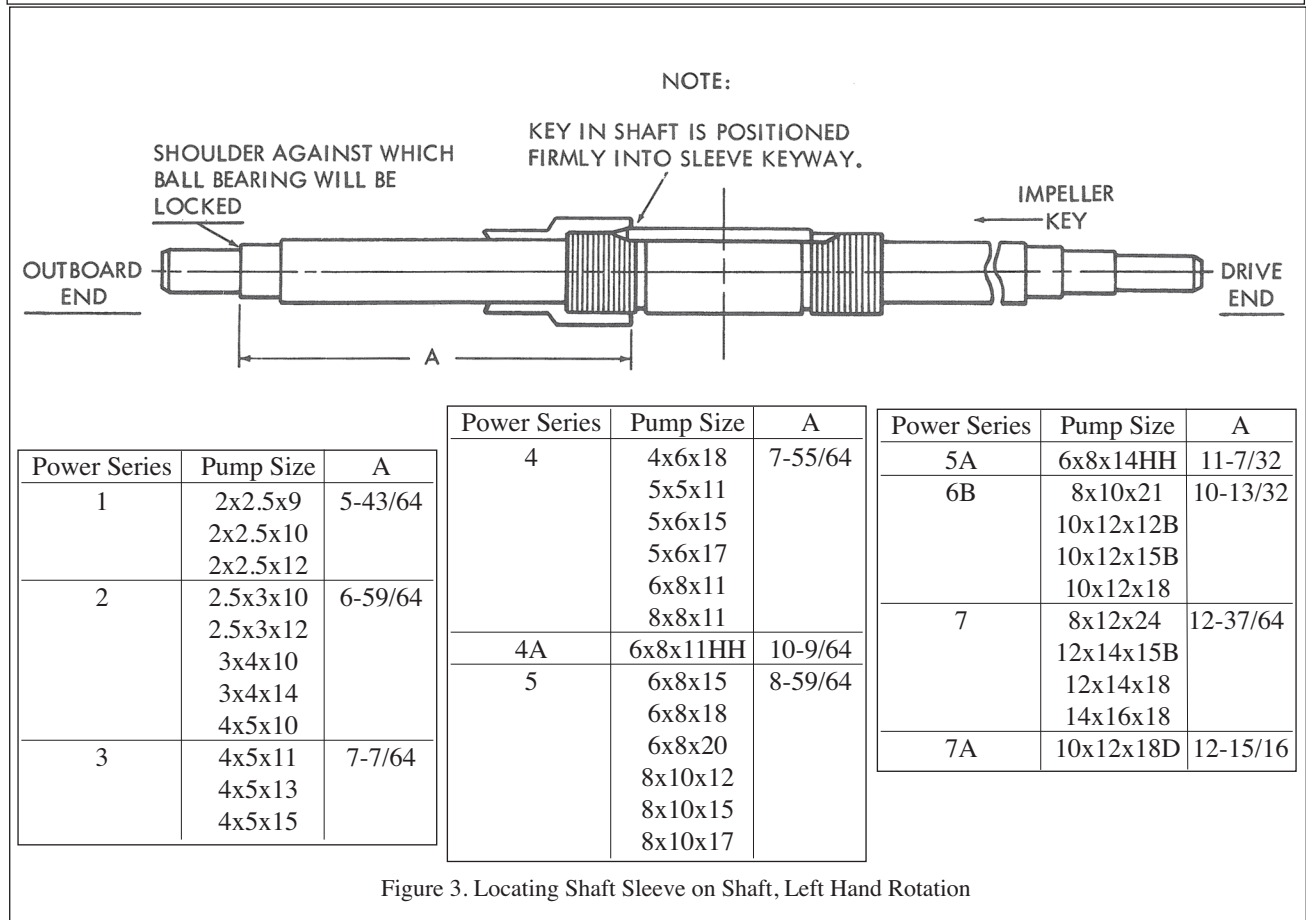

Figure 3. Locating Shaft Sleeve on Shaft, Left Hand Rotation

DISASSEMBLY OF A PUMP WITH MECHANICAL SEALS

1. Perform disassembly procedure as previously given through step 8.
2. Loosen and remove four nuts (18) and washers (19) thus freeing swing bolts (22) to allow shaft and impeller assembly to be lifted from casing half (69) with sling and hoist or crane as described in paragraph 10 above.

CAUTION

Use extreme care in moving this assembly, because sliding loose on the shaft can crack ceramic seats. To prevent this, wrap seal securely in a cloth to stop it from sliding on shaft.

3. With shaft and impeller assembly on a suitable bench, cradle, or work stand, loosen and remove pipe plug (12) from inboard cartridge cap (42). Remove grease zerk (10) and cap screws (41) and slide cartridge cap with grease seal (43) off end of this shaft (65). Remove gasket (44)
4. Either pull or press bearing cartridge (45), grease seal (46) and bearing (47) off shaft. Remove slinger (48).

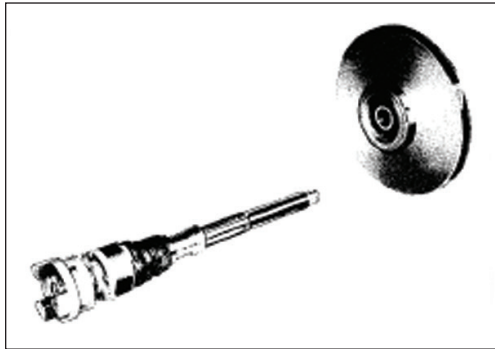

F. Impeller removed from outboard rotating element.

5. The one piece gland (49) used with mechanical seal assembly can now be removed from the shaft.
6. O-ring (50) can be removed from seal gland if desired.)

CAUTION

7. Exercise great care in removing seal assembly (53) to keep from marring or otherwise damaging precision ground mating surfaces.
8. Scribe a mark on shaft sleeve for relocating seal collar on reassembly. Loosen setscrews (55), securing seal collars (54) to shaft sleeves and slide them off.

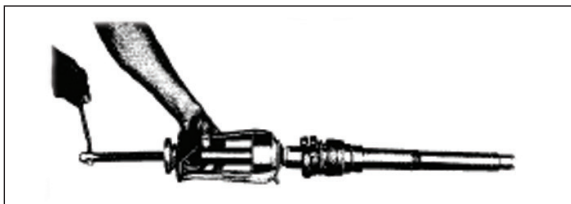

G. Removing bearing from shaft using conventional puller.

9. Proceed with further disassembly of outboard seal assembly using the same procedure.

10. After removal of mechanical seals, proceed with balance of disassembly in same manner as described for packing design.

REASSEMBLY

Reassembly will generally be in reverse order of disassembly. If disassembly was not complete use only those steps related to your particular repair program.

1. For Model 412, 413 & 483 pumps, reassemble base (77) to casing half (69) with capscrews (76). Set these parts back on their foundation and connect them to the suction and discharge piping, then secure the base to its foundation by tightening nuts on foundation bolts.

2. Position locating pins (67) in lower casing (69), adding swing bolt pins (68), if used on your pump. Install wearing ring pins (66). Tap pins gently to seat them in place. If name plate (71) was removed, install it with screws (70). Install o-ring (62) in shaft sleeve

3. On right hand unit, thread inboard sleeve (64) onto shaft (65) distance "A" (refer to figure 2). On left hand unit, thread outboard sleeve (57) onto the shaft distance "A" (refer to figure 3). When the sleeve is in position its keyway should align with keyway on shaft. Coat key and keyway with loctite sealant grade 242. Insert key (63) into keyways of shaft and sleeve. Tap it firmly in place.

4. Coat inside diameter of impeller wearing rings (61) (optional) with Loctite sealant grade 271 and press them over hubs of impeller (59). Do not attempt to hammer impeller wear rings into position, since they are press fit. Use of an arbor press is preferred. However, placing a block of wood over the impeller wearing ring and pressing it in will work satisfactorily. For power frames 5, 6B, and 7 only, two setscrews (78) will be installed by drilling into wearing rings and impeller. The opposite surface for the impeller should be protected from damage throughout the procedures by resting it against soft wood on the surface of workbench.



H. Shaft with sleeve and key in position.

CAUTION

Impeller wearing ring must be given special care because they press fit. Be sure rings are positioned squarely over the hub of impeller. A softheaded hammer may be used to gently tap impeller wearing rings into correct alignment before they are pressed into place.

5. Coat impeller (59) keyway with loctite sealant grade 242 and slide onto shaft until it is firmly against the shaft sleeve. Place o-ring (58) in shaft sleeve (57) and thread shaft sleeve firmly against the impeller.

NOTE

When assembling rotation element of a 410 series pump, it is important that the curve of the impeller blades is in agreement with pump rotation (see insert in figures 4, 5, and 6).

MODELS 411 & 481, 412, 413 & 483

6. Install packing or mechanical seals and secure according to the following specific instructions.

STANDARD PACKING

a. Slide a bushing (56) onto each end of shaft. The raised shoulder on these bushings must face away from impeller.

b. Pump sizes 2 x 2-1/2 x 9, 2 x 2-1/2 x 10, 2 x 2-1/2 x 12 have one packing ring (23) in front of lantern ring (52). All other pump sizes have two packing rings in front of lantern ring. Stagger the joints in packing rings so pump will not leak excessively.

MECHANICAL SEALS

a. Single seal and balanced single seals

I. Slide one seal lock collar (54) with setscrews (55) facing the impeller onto each end of the shaft. Position on scribe mark made during disassembly and lock in place.

II. Put a light coat of liquid dishwashing detergent on the shaft sleeve. Check rotating parts of seal to make sure they are clean. Spread a light coat of liquid detergent on inside diameters of flexible bellows and washers.

III. Place the seal's spring, drive ring, retainer, flexible bellows, and washer on the shaft sleeve in respective order. (Refer to figure 1)

IV. Thoroughly inspect cavity of seal gland (49) for burrs or nicks which would damage seat of the seal. Apply a film of liquid detergent to seal seat and install it in seal gland cavity, taking care to seat it evenly and squarely.

NOTE

If it is not possible to insert the seat with fingers, place a cardboard protecting ring (furnished with seal) over lapped face of seat and press into place with a piece of tubing having end cut square. Tubing should be slightly larger than the diameter of the shaft. Remove cardboard after the seat is firmly in place.

CAUTION

Never place a mechanical seal into service after it has been used without replacing or relapping stationary seat and washer faces.

V. Place O-rings (50) around the seal glands and slide seal glands onto the ends of the shaft.

b. Double Seal

I. Place one seal seat in collar (54), the other one fits into seal gland (49). These parts are set into their cavities in the same manner as they are with a single seal.

II. Place o-rings (51) around collars (54) and put the collars with stationary seats facing away from impeller on ends of the shaft, then slide flexible bellows, washers, and springs on the shaft in order shown in figure 1, for each half of double seal assembly (53).

III. Place o-rings (50) around the seal glands (49) and slide seal glands onto ends of the shaft with stationary seats facing impeller.

7. Place slinger (39) on outboard end of shaft.

8. Press grease seal (37) into bearing cartridge (36). On 6B, 7A and 7 Power Frames replace snap ring (35A) on inboard side of bearing. Place outboard double row ball bearing (38) in bearing cartridge and press these parts onto outboard end of the shaft. Snap retainer ring (35) in place to secure outboard bearing. Place gasket (43) and cartridge cap (32) in position and secure with capscrews (31).

NOTE

Model 412, 413 & 483 - Both the grease zerk holes in bearing cartridges and the pipe plugholes in cartridge caps must be facing the front of pump when it is assembled.

9. Protector (29) can be placed in the cartridge cap or, if unit has a tandem shaft, press grease seal into cartridge cap and slide a slinger onto shaft.

10. Place slinger (48) on inboard end of the shaft.

11. Press grease seal (46) into bearing cartridge (45). Place the inboard bearing (47) into the bearing cartridge and press this assembly onto inboard end of the shaft.

12. Press grease seal (43) into cartridge cap (42). Position gasket (44) and cartridge cap against bearing cartridge and secure it in place with capscrews (41). Be sure to align grease zerk hole and pipe plughole to the front.

13. Place slinger (40) onto shaft. Place grease zerks (10) in bearing cartridges and pipe plugs (12) in bearing caps. If pump is oil lubricated, breather tubes are placed in bearing cartridges and oilers with nipples and elbows are placed in cartridge caps.

14. Slide casing wearing rings (28) over impeller wearing rings (61) and set rotating elements into casing halves (69). Make certain the holes that are drilled in bottom of surface of casing wearing rings locate over pins (66) previously set in casing half (69). Grease zerks or breather tube should face outward.

15. Install key (24) in motor end of shaft (65). Check position and alignment of packing rings or seal components and install swing bolts (22) and split gland halves (21) if the pump has packing. Place in position clamps (20), washers (19), and nuts (18) securing loosely in place. Swing bolts (22) are set over pins (68) on 4x5x10 or smaller pumps. On larger pumps swing bolts are held in place by capscrews (7) after casing half (8) is in position.

16. Place pins (27) into bearing cartridges. Place bearing caps (26) in position and secure with capscrews (25)

17. Position new casing gaskets (9) on casing half (69). Set casing half (8) in place and secure it to casing half (69) with capscrews (6). Pins (67) are used as means of locating position of the two casing halves.

18. On pumps larger than 4x5x10, thread in capscrews (7) making sure they are placed through the eyes of swing bolts (22).

19. Place drain plugs (1) and (2) back in the casing halves.

MODELS 411 & 481, 412, 413 & 483

20. On model 413 & 483 pumps, set the motor on motor bracket (74) and fasten them together with capscrews (73). Slide the flexible coupling halves onto the pump and motor shafts. Attach motor bracket to casing half (69) with capscrews (75). Connect flexible coupling halves. On model 412 pumps, attach flexible shafting. Ideal joint operating angle is 1" to 5". On Model 411 pumps, if lower casing was removed from the base, see section on installation for proper methods of realigning pump to motor and piping.

21. Replace any flushing, cooling, by-pass or drain lines that were removed from the pump. Connect electricity back to the motor.

STARTING PUMP AFTER REASSEMBLY – Do not start pump until all air and vapor have been bled and making sure that there is liquid in pump to provide necessary lubrication.

NOTE

Do not over tighten standard packing assembly before returning unit to operation. Jog the pump to check for proper rotation. Then allow pump to run for a short time, gradually tighten nuts (18) until dripping has been reduced to its normal level.

MODEL 411 & 481 LIST OF PARTS (See Figure 4)

1. Plug	26. Bearing Cap	43. Grease Seal	59. Impeller
2. Plug	27. Pin	44. Gasket	60. Sleeve Pin
6. Capscrew	28. Wearing Ring	45. Cartridge	61. Wearing Ring
7. Capscrew	29. Protector	46. Grease Seal	62. O-Ring
8. Casing	31. Capscrew	47. Bearing	63. Key
9. Gasket	32. Cartridge Cap	48. Slinger	64. Sleeve
10. Grease Fitting	34. Gasket	49. Gland	65. Shaft
12. Plug	35. Retaining Ring	50. O-Ring	66. Pin
18. Nut	35A. Retaining Ring	51. O-Ring	67. Pin
19. Washer	36. Cartridge	52. Lantern Ring	68. Pin
20. Clamp	37. Grease Seal	53. Seal	69. Casing
21. Gland Half	38. Bearing	54. Collar	70. Drivescrew
22. Swing Bolt	39. Slinger	55. Setscrew	71. Nameplate
23. Packing	40. Slinger	56. Bushing	72. Setscrew
24. Key	41. Capscrew	57. Sleeve	78. Setscrew
25. Capscrew	42. Cartridge Cap	58. O-Ring	79. Sleeve Collar

MODEL 412 LIST OF PARTS (See Figure 5)

1. Plug	26. Bearing Cap	43. Grease Seal	59. Impeller
2. Plug	27. Pin	44. Gasket	60. Sleeve Pin
6. Capscrew	28. Wearing Ring	45. Cartridge	61. Wearing Ring
7. Capscrew	29. Protector	46. Grease Seal	62. O-Ring
8. Casing	31. Capscrew	47. Bearing	63. Key
9. Gasket	32. Cartridge Cap	48. Slinger	64. Sleeve
10. Grease Fitting	34. Gasket	49. Gland	65. Shaft
12. Plug	35. Retaining Ring	50. O-Ring	66. Pin
18. Nut	35A. Retaining Ring	51. O-Ring	67. Pin
19. Washer	36. Cartridge	52. Lantern Ring	68. Pin
20. Clamp	37. Grease Seal	53. Seal	69. Casing
21. Gland Half	38. Bearing	54. Collar	70. Drivescrew
22. Swing Bolt	39. Slinger	55. Setscrew	71. Nameplate
23. Packing	40. Slinger	56. Bushing	72. Setscrew
24. Key	41. Capscrew	57. Sleeve	78. Setscrew
25. Capscrew	42. Cartridge Cap	58. O-Ring	79. Sleeve Collar

MODEL 413 & 483 LIST OF PARTS (See Figure 6)

1. Plug	26. Bearing Cap	43. Grease Seal	59. Impeller
2. Plug	27. Pin	44. Gasket	60. Sleeve Pin
6. Capscrew	28. Wearing Ring	45. Cartridge	61. Wearing Ring
7. Capscrew	29. Protector	46. Grease Seal	62. O-Ring
8. Casing	31. Capscrew	47. Bearing	63. Key
9. Gasket	32. Cartridge Cap	48. Slinger	64. Sleeve
10. Grease Fitting	34. Gasket	49. Gland	65. Shaft
12. Plug	35. Retaining Ring	50. O-Ring	66. Pin
18. Nut	35A. Retaining Ring	51. O-Ring	67. Pin
19. Washer	36. Cartridge	52. Lantern Ring	68. Pin
20. Clamp	37. Grease Seal	53. Seal	69. Casing
21. Gland Half	38. Bearing	54. Collar	70. Drivescrew
22. Swing Bolt	39. Slinger	55. Setscrew	71. Nameplate
23. Packing	40. Slinger	56. Bushing	72. Setscrew
24. Key	41. Capscrew	57. Sleeve	78. Setscrew
25. Capscrew	42. Cartridge Cap	58. O-Ring	79. Sleeve Collar

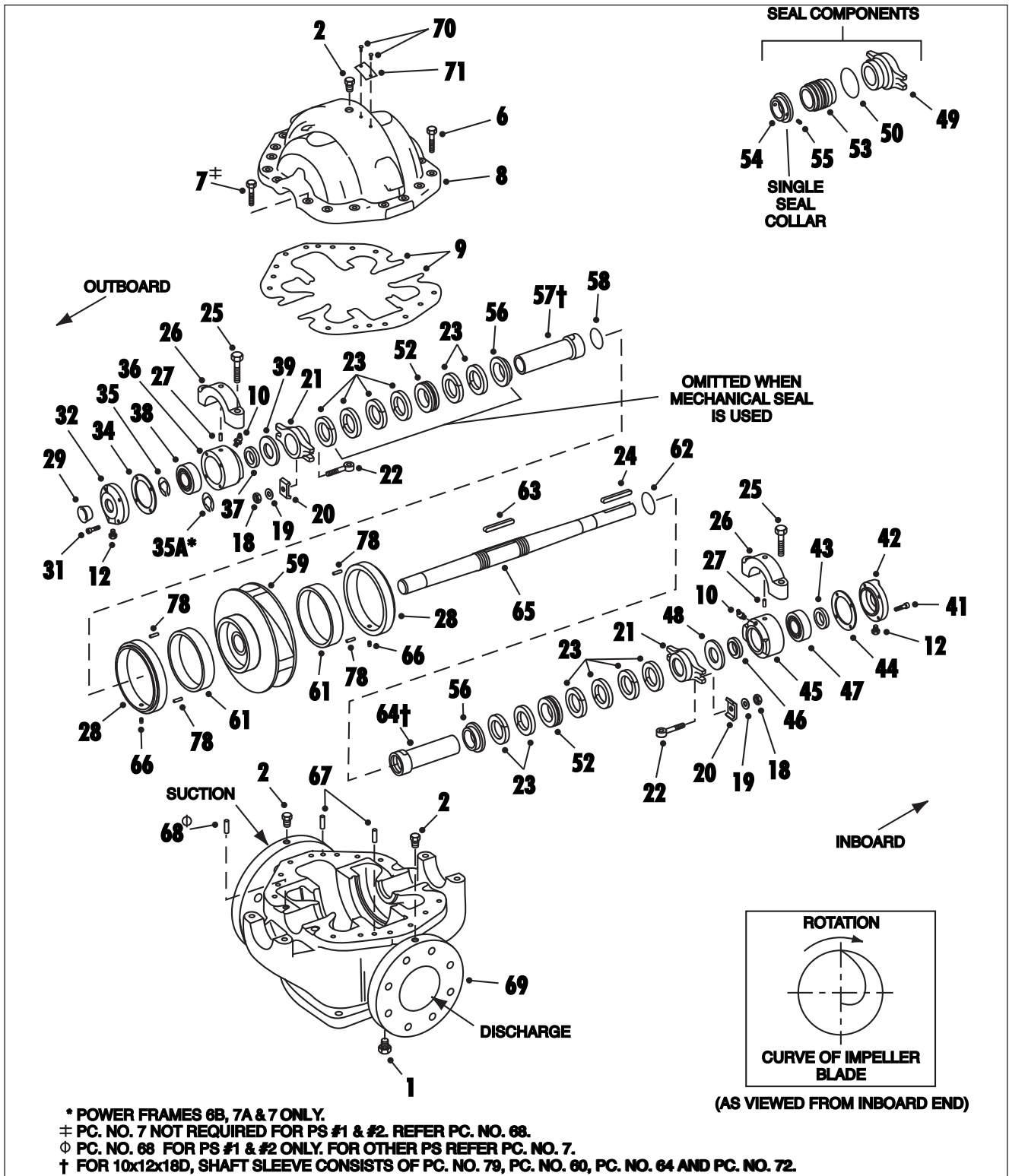

Figure 4. Model 411 & 481 Exploded View

NOTE

WHEN ORDERING SPARE PARTS ALWAYS INCLUDE THE PUMP TYPE, SIZE, SERIAL NUMBER AND THE PIECE NUMBER FROM THIS EXPLODED VIEW IN THIS MANUAL.

ORDER ALL PARTS FROM YOUR LOCAL AUTHORIZED DISTRIBUTOR, FACTORY BRANCH SALES OFFICE OR THE FACTORY AT NORTH AURORA, ILLINOIS.

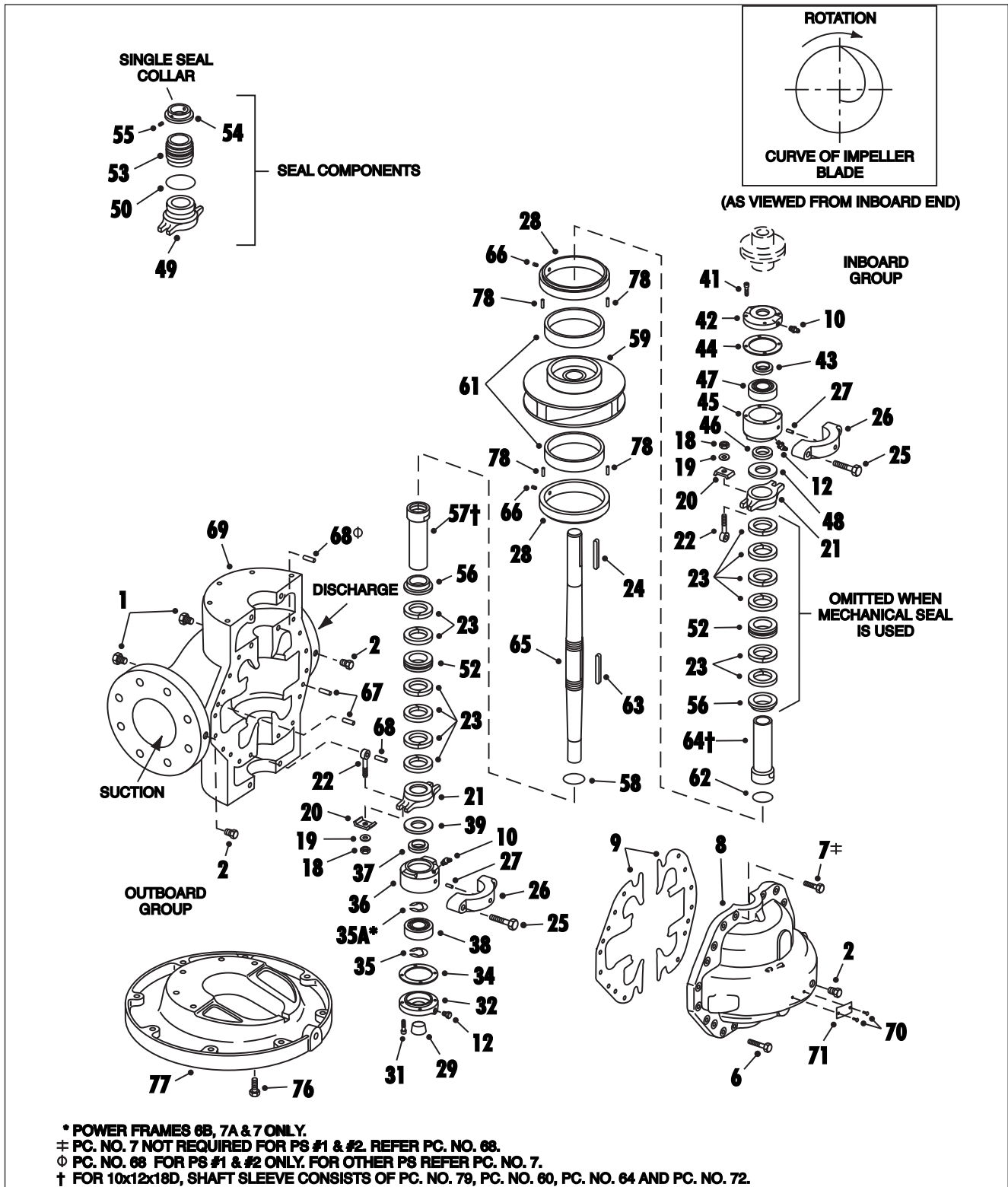

Figure 5. Model 412 Exploded View

NOTE

WHEN ORDERING SPARE PARTS ALWAYS INCLUDE THE PUMP TYPE, SIZE, SERIAL NUMBER AND THE PIECE NUMBER FROM THIS EXPLODED VIEW IN THIS MANUAL.

ORDER ALL PARTS FROM YOUR LOCAL AUTHORIZED DISTRIBUTOR, FACTORY BRANCH SALES OFFICE OR THE FACTORY AT NORTH AURORA, ILLINOIS.

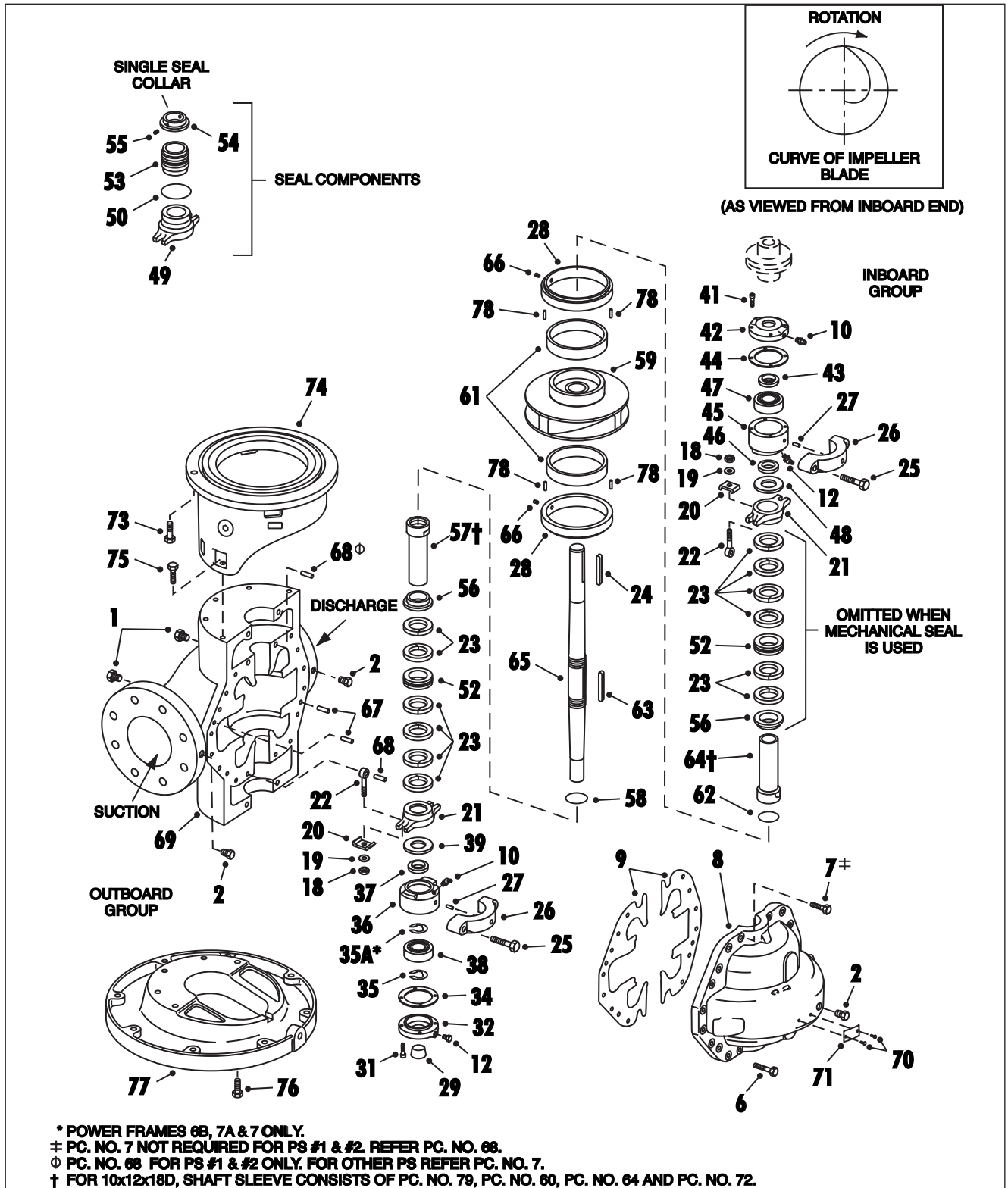

Figure 6. Model 413 & 483 Exploded View

NOTE

WHEN ORDERING SPARE PARTS ALWAYS INCLUDE THE PUMP TYPE, SIZE, SERIAL NUMBER AND THE PIECE NUMBER FROM THE EXPLODED VIEW IN THIS MANUAL.

ORDER ALL PARTS FROM YOUR LOCAL AUTHORIZED DISTRIBUTOR, FACTORY BRANCH SALES OFFICE OR THE FACTORY AT NORTH AURORA, ILLINOIS.

WARRANTY

Seller warrants equipment (and its component parts) of its own manufacture against defects in materials and workmanship under normal use and service for one (1) year from the date of installation or start-up, or for eighteen (18) months after the date of shipment, whichever occurs first. Seller does not warrant accessories or components that are not manufactured by Seller; however, to the extent possible, Seller agrees to assign to Buyer its rights under the original manufacturer's warranty, without recourse to Seller. Buyer must give Seller notice in writing of any alleged defect covered by this warranty (together with all identifying details, including the serial number, the type of equipment, and the date of purchase) within thirty (30) days of the discovery of such defect during the warranty period. No claim made more than 30 days after the expiration of the warranty period shall be valid. Guarantees of performance and warranties are based on the use of original equipment manufactured (OEM) replacement parts. Seller assumes no responsibility or liability if alterations, non-authorized design modifications and/or non-OEM replacement parts are incorporated. If requested by Seller, any equipment (or its component parts) must be promptly returned to Seller prior to any attempted repair, or sent to an authorized service station designated by Seller, and Buyer shall prepay all shipping expenses. Seller shall not be liable for any loss or damage to goods in transit, nor will any warranty claim be valid unless the returned goods are received intact and undamaged as a result of shipment. Repaired or replaced material returned to customer will be shipped F.O.B., Seller's factory. Seller will not give Buyer credit for parts or equipment returned to Seller, and will not accept delivery of any such parts or equipment, unless Buyer has obtained Seller's approval in writing. The warranty extends to repaired or replaced parts of Seller's manufacture for ninety (90) days or for the remainder of the original warranty period applicable to the equipment or parts being repaired or replaced, whichever is greater. This warranty applies to the repaired or replaced part and is not extended to the product or any other component of the product being repaired. Repair parts of its own manufacture sold after the original warranty period are warranted for a period of one (1) year from shipment against defects in materials and workmanship under normal use and service. This warranty applies to the replacement part only and is not extended to the product or any other component of the product being repaired. Seller may substitute new equipment or improve part(s) of any equipment judged defective without further liability. All repairs or services performed by Seller, which are not covered by this warranty, will be charged in accordance with Seller's standard prices then in effect.

THIS WARRANTY IS THE SOLE WARRANTY OF SELLER AND SELLER HEREBY EXPRESSLY DISCLAIMS AND BUYER WAIVES ALL OTHER WARRANTIES EXPRESSED, IMPLIED IN LAW OR IMPLIED IN FACT, INCLUDING ANY WARRANTIES OF MERCHANTABILITY OR FITNESS FOR A PARTICULAR PURPOSE. Seller's sole obligation under this warranty shall be, at its option, to repair or replace any equipment (or its component parts) which has a defect covered by this warranty, or to refund the purchase price of such equipment or part. Under the terms of this warranty, Seller shall not be liable for (a) consequential, collateral, special or liquidated losses or damages; (b) equipment conditions caused by normal wear and tear, abnormal conditions of use, accident, neglect, or misuse of said equipment; (c) the expense of, and loss or damage caused by, repairs or alterations made by anyone other than the Seller; (d) damage caused by abrasive materials, chemicals, scale deposits, corrosion, lightning, improper voltage, mishandling, or other similar conditions; (e) any loss, damage, or expense relating to or resulting from installation, removal or reinstallation of equipment; (f) any labor costs or charges incurred in repairing or replacing defective equipment or parts, including the cost of reinstalling parts that are repaired or replaced by Seller; (g) any expense of shipment of equipment or repaired or replacement parts; or (h) any other loss, damage or expense of any nature.

The above warranty shall not apply to any equipment which may be separately covered by any alternate or special warranties.

PERFORMANCE: In the absence of Certified Pump Performance Tests, equipment performance is not warranted or guaranteed. Performance curves and other information submitted to Buyer are approximate and no warranty or guarantee shall be deemed to arise as a result of such submittal. All testing shall be done in accordance with Seller's standard policy under Hydraulic Institute procedures.

LIABILITY LIMITATIONS: Under no circumstances shall the Seller have any liability under the Order or otherwise for liquidated damages or for collateral, consequential or special damages or for loss of profits, or for actual losses or for loss of production or progress of construction, regardless of the cause of such damages or losses. In any event, Seller's aggregate total liability under the Order or otherwise shall not exceed the contract price.

ACTS OF GOD: Seller shall in no event be liable for delays in delivery of the equipment or other failures to perform caused by fires, acts of God, strikes, labor difficulties, acts of governmental or military authorities, delays in transportation or procuring materials, or causes of any kind beyond Seller's control.

COMPLIANCE WITH LAW: Seller agrees to comply with all United States laws and regulations applicable to the manufacturing of the subject equipment. Such compliance shall include: The Fair Labor Standards Acts of 1938, as amended; Equal Employment Opportunity clauses of Executive Order 11246, as amended; Occupational Safety and Health Act of 1970 and the standards promulgated thereunder, if applicable. Since compliance with the various Federal, State, and Local laws and regulations concerning occupational health and safety, pollution or local codes are affected by the use, installation and operation of the equipment and other matters over which Seller has no control, Seller assumes no responsibility for compliance with those laws and regulations, whether by way of indemnity, warranty, or otherwise. It is incumbent upon the Buyer to specify equipment which complies with local codes and ordinances.



800 Airport Road
North Aurora, Illinois 60542
630-859-7000
www.aurorapump.com