

Etaprime – Horizontal Single Stage Self Priming Pump

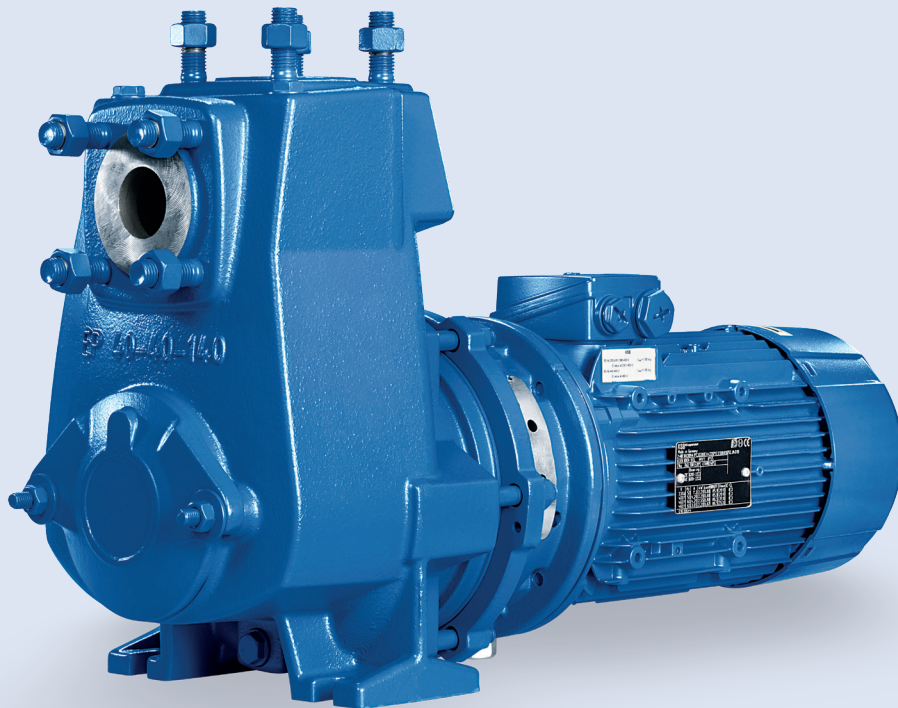

Etaprime B

Applications:

- Water supply
- Fire-fighting systems
- Spray irrigation
- General irrigation
- Drainage
- Cooling water
- Air-conditioning systems
- Drinking water
- Service water
- Swimming pool water
- Seawater
- Fire-fighting water
- Brackish water
- Condensate
- Brine
- Oils
- Cleaning agents

For more information, visit:
ksb.us.com

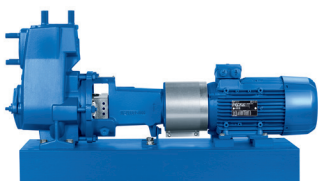

Etaprime L

Etaprime – Horizontal Single Stage Self Priming Pump

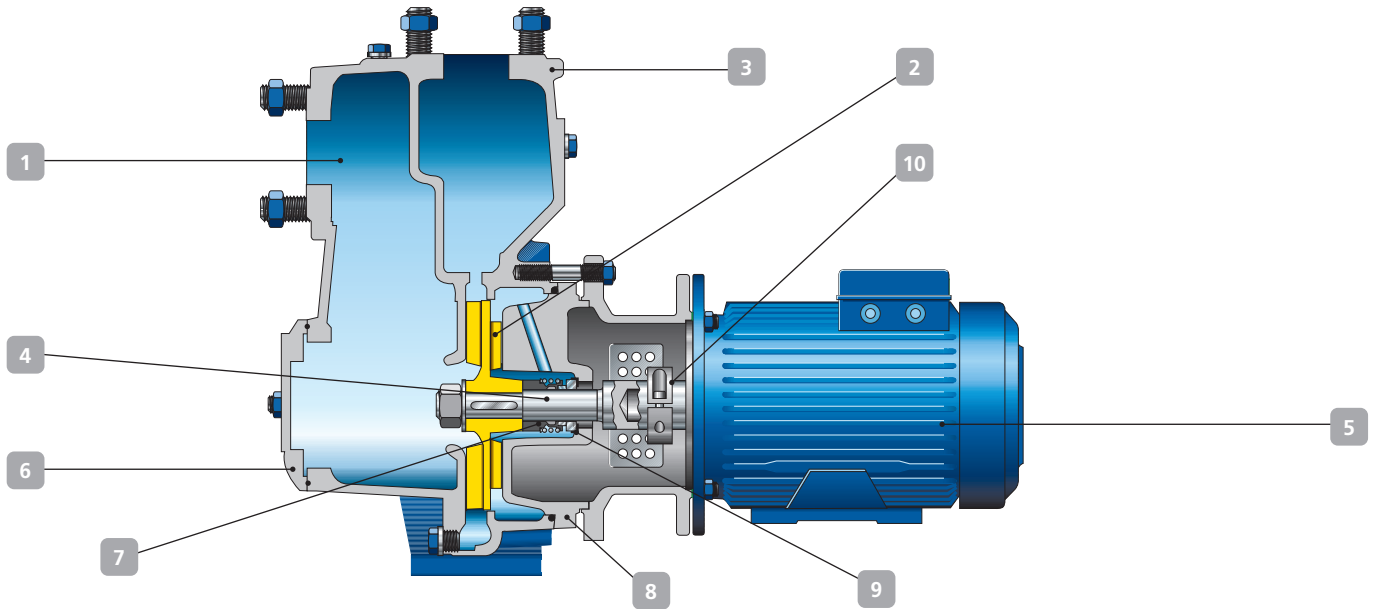

- 1 Self-priming**
after the pump casing has been filled with the fluid handled.
- 2 Excellent suction behavior**
Self-priming up to 30 ft. No foot valve required.
- 3 Insensitive**
to the penetration of gas and air.
- 4 Double mechanical seal**
Tandem and back-to-back. Available for tough applications.
- 5 Service-friendly**
thanks to robust KSB IE3 motor to IEC 60034-30
- 6 Easy to clean**
via inspection cover.
- 7 Wear-resistant**
Shaft sleeve prevents wear on the shaft.
- 8 Simple dismantling**
Back pull-out design: The casing may remain in the piping while the pump is dismantled.
- 9 Reliable operation**
Maintenance-free mechanical seal.
- 10 Compact design**
Close-coupled version (Etaprime B). Pump without separate coupling, which eliminates the need for coupling alignment.
- Diverse bearing lubrication options**
Etaprime L: Bearings grease-packed for life or oil-lubricated (constant level oiler or oil indicator).
- Diverse bearing monitoring options**
Etaprime L: Connection options for temperature and shock pulse measurement.

Materials

Cast iron, 316 Stainless steel

Technical data

	Etaprime L	Etaprime B
Max. capacity	792 gpm	660 gpm
Max. discharge head	344 ft.	328 ft.
Fluid temperature	-20 to 194° F	-20 to 194° F
Pump discharge pressure	232 psi	232 psi



PUFFER Rotating Equipment
Pumps & Parts • Pump Skids • Repairs & Services

12305 Kurland Dr, Houston, TX 77034
RotatingEquipment@puffer.com 281-240-2000

KSB
Authorized Sales Partner