

Magnochem 685 – Heavy Duty Centrifugal Pump

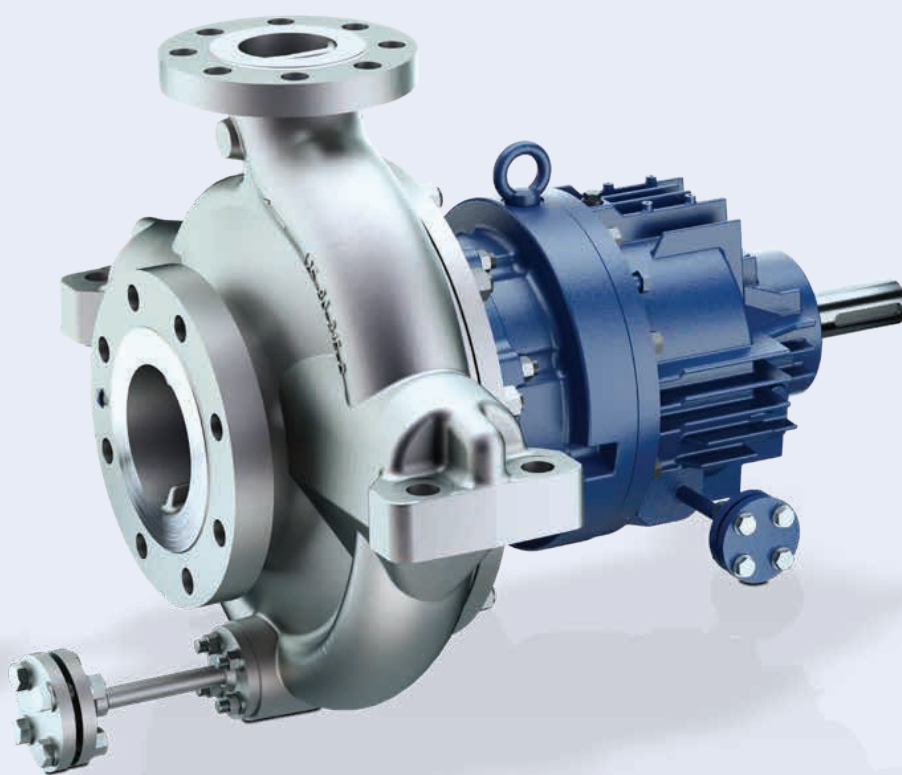

Applications:

For handling all clear valuable, aggressive, toxic, flammable, malodorous or harmful fluids in oil&gas, petrochemical, chemical and general industries.

More information:

www.ksb.com/products

Magnochem 685 – Heavy Duty Centrifugal Pump with Magnetic Coupling

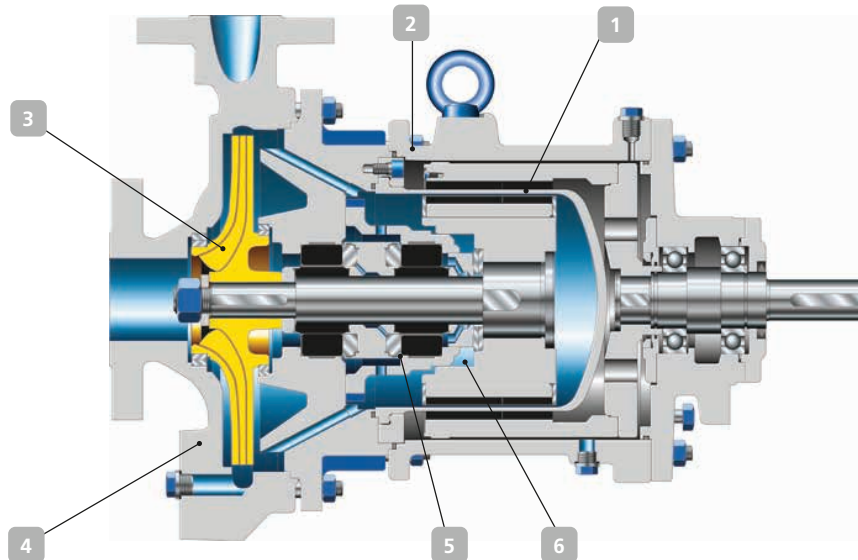

1 Further development of the tried and tested mag-drive pump

- Optimised modular system for magnetic couplings
- Multiple patents pending

2 Excellent energy efficiency

- Modern, energy-efficient design
- Optimised hydraulic system
- Ceramic loss-free containment shroud as standard

3 Expanded performance range

- Expanded temperature range
- Several operating modes and many flushing plan options
- Suitable for all applications

4 Heavy Duty Installation

- Centerline mounted casing
- Two times nozzle loads of API 685 table 4 requirements
- Baseplate, coupling and guard as per API 685

5 High availability and low operating costs

- acc. to API 685 and DIN EN ISO 15783
- Reduction in required stock levels
- Unbeaten mean time between failures

6 Maximum operating reliability

- standard lifetime silicon carbide bearings
- optional DLC-coated plain bearings made of silicon carbide with optimised dry-running properties
- Optional leakage barrier and/or control system

KSB as competent and experienced partner

Comprehensive product portfolio for conventionally sealed pumps, mag-drive and canned motor pumps

Technical data	50 Hz	60 Hz
DN [mm]	25 – 250	25 – 250
DN [Zoll]	1 – 10	1 – 10
Q [m³/h]	1,160 max.	1,400 max.
Q [US.gpm]	5,110 max.	6,160 max.
H [m]	162 max.	233 max.
H [ft]	530 max.	764 max.
p [bar]	40 max.	40 max.
p [psi]	580 max.	580 max.
T [°C]	+350 max.	+350 max.
T [°F]	+660 max.	+660 max.



PUFFER Rotating Equipment
Pumps & Parts ▪ Pump Skids ▪ Repairs & Services

12305 Kurland Dr, Houston, TX 77034
RotatingEquipment@puffer.com 281-240-2000

KSB
Authorized Sales Partner