

RPH-HW – Hot Water Recirculation Pump

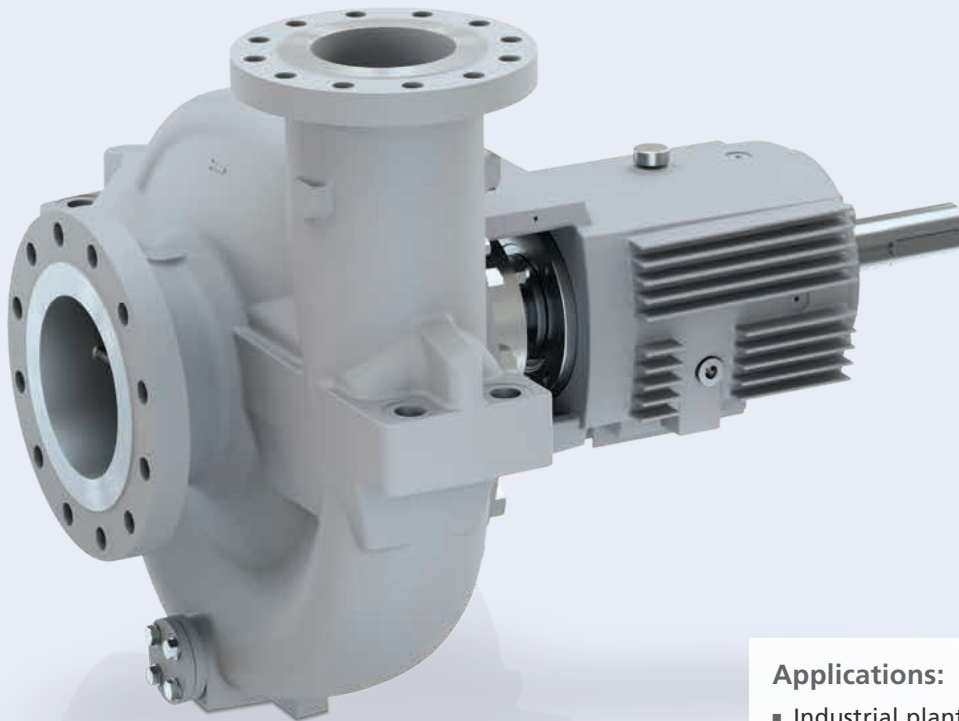

Applications:

- Industrial plants
- Small to medium-sized power plants

More information: www.ksb.com

RPH-HW – Hot Water Recirculation Pump

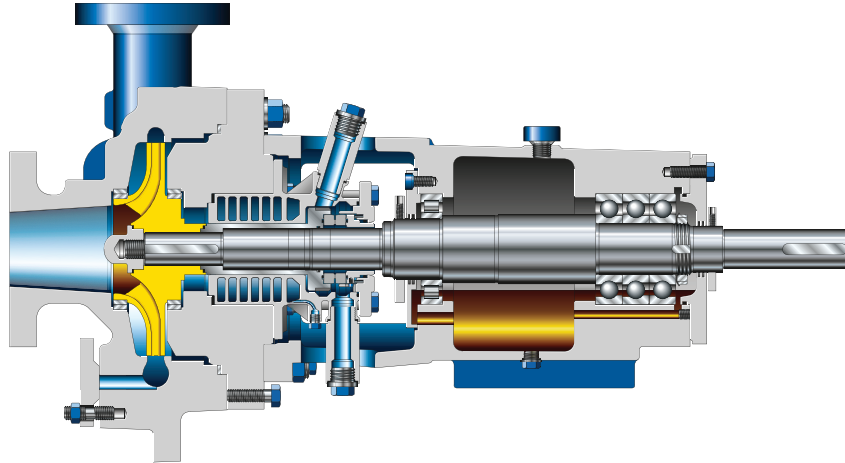

1 Robust design for long service life and low maintenance costs

- Casing with centreline pump feet ensures reliable operation and correct alignment at high temperatures.
- Volute casing with double volute (from DN 80) reduces radial forces and shaft deflection, thus reducing the load on bearings and mechanical seals.
- Robust and cost-effective component seal can be used across a wide pressure and temperature range.

2 Long service life and high level of reliability of bearings

- Oil lubrication with constant level oiler and labyrinth seal
- Angular contact ball bearings in triple arrangement, dimensioned for high inlet pressures and bearing life over 17,500 hours (L10h).
- An optimised shaft and individual selection of the balancing holes ensure reduced axial forces, low vibrations and a long service life of the bearings and shaft seal.

3 High system availability due to efficient cooling

- Intensive cooling of the seal chamber via replaceable high-efficiency cooling insert
- Additional cooling via tube-in-tube heat exchanger is possible if required.
- Effective self-cooling of the bearing bracket through integrated cooling fins and optional fan impeller
- Bearing bracket with water cooling available on request

4 Ease of maintenance

- Back pull-out design and forcing screws allow for easy dismantling and maintenance.
- Replaceable casing and impeller wear rings
- Constant level oiler ensures even lubrication of the bearings and makes it easy to check the oil level.
- Modular design system reduces spare parts stock.

Materials	Technical data	50 Hz	60 Hz
	S6 (cast steel) C6 (12 % chrome steel)	Max. flow rate	1800 m ³ /h / 7925 US gpm
	Max. head	270 m / 886 ft	
	Max. temperature	+320 °C / +608 °F	
	Max. pressure	110 bar / 1595 psi	
	Nominal size	25 – 300 mm / 1 – 12 in	

Other values on request



PUFFER Rotating Equipment
Pumps & Parts ▪ Pump Skids ▪ Repairs & Services

12305 Kurland Dr, Houston, TX 77034
RotatingEquipment@puffer.com 281-240-2000



Authorized Sales Partner