

## RPH-LF – Single-suction, Single-stage Heavy-duty OH2 Process Pump

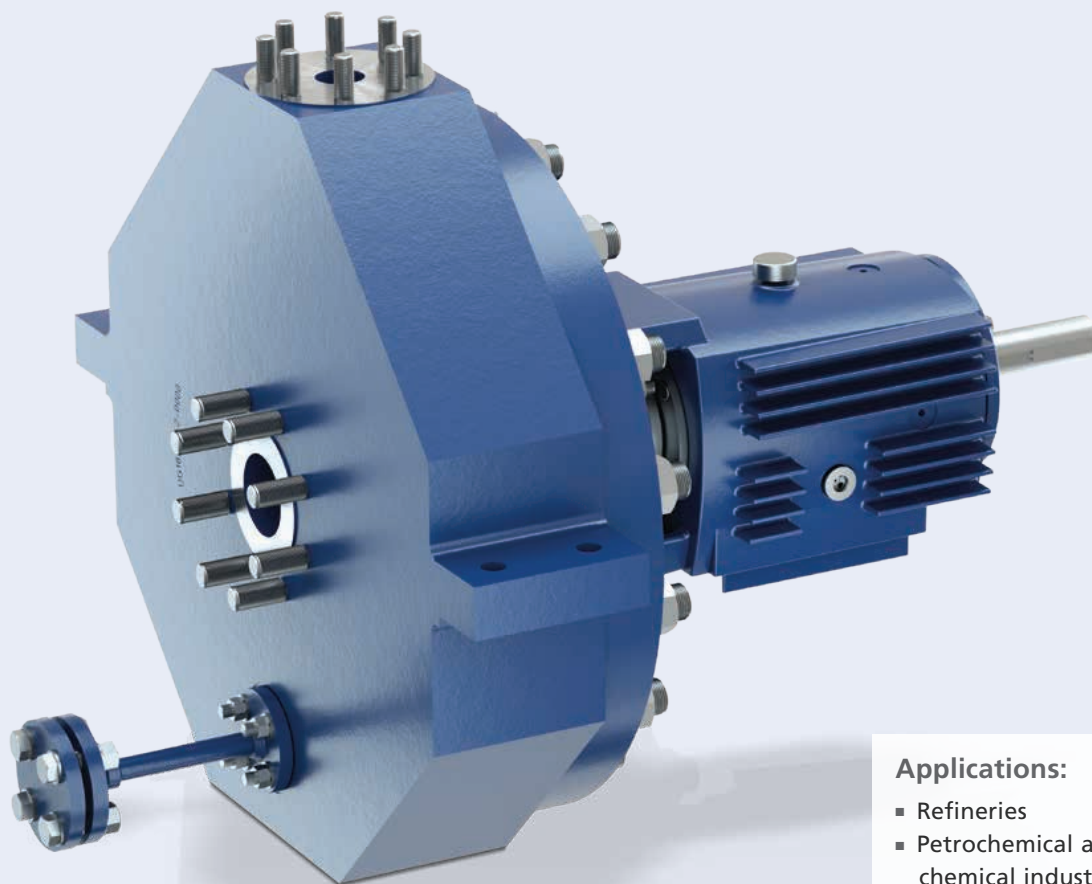

### Applications:

- Refineries
- Petrochemical and chemical industries
- Onshore and offshore processes

More information: [www.ksb.com](http://www.ksb.com)

# RPH-LF – Single-suction, Single-stage Heavy-duty OH2 Process Pump to API 610 / ISO 13709

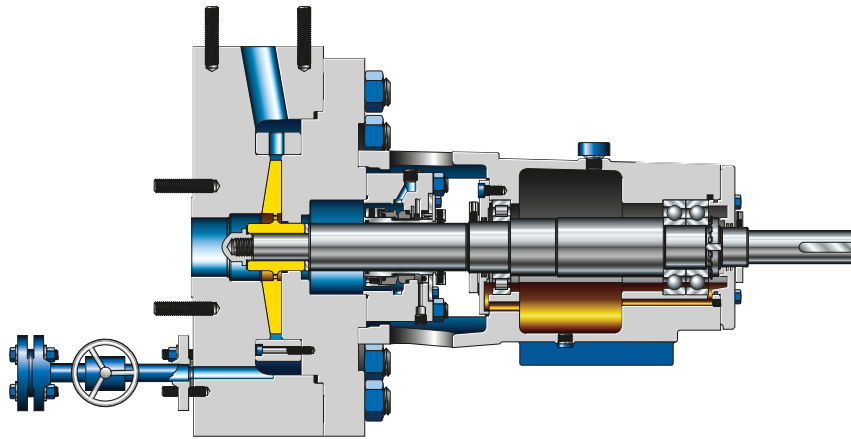

- Low flow rates and high heads**
  - RPH-LF offers a very stable hydraulic performance, meets the requirements of the current API 610 standard and is ATEX-approved.
  - Various impeller sizes and diffuser versions are available and can easily be adjusted to create tailored hydraulic solutions.
- Innovative design**
  - Innovative hydraulic design, easy to match to the required duty point
  - Machined from a single piece. No radiographic testing required.
  - Large inlet area for good NPSH values without inducer
- Long service life of the mechanical seal**

Maximum permissible shaft diameter to API 610 minimising shaft deflection and vibrations

- High flexibility**

ANSI B16.5 Class 300 and Class 600 flanges available as standard. Various nozzle configurations with no extra capital investment that match the on-site piping system.
- Long service life and high reliability of bearings**
  - Heavy-duty 40° angular contact thrust bearings exceeding API requirements
  - Oil bath or oil mist lubrication
- No cooling water circuit required**

When fluid temperature and ambient temperature are high, the steel bearing bracket with integrated cooling fins and the optional fan impeller protect the unit from overheating.
- Ease of maintenance**

Mechanical seals to ISO 24109 / API 682 in cartridge design are easy to install/remove for maintenance.

Materials	Technical data	50 Hz	60 Hz
S5, S6, S8, C6, A8, D1 and special materials	Max. flow rate	40 m <sup>3</sup> /h / 176 US gpm	
	Max. head	339 m / 1112 ft	488 m / 1601 ft
	Max. temperature	-30 to +200 °C / -20 °F to 392 °F	
	Max. pressure	110 bar / 1595 psi	
	Nominal diameter	50 mm / 2 in	

Other values on request



**PUFFER** Rotating Equipment  
Pumps & Parts ▪ Pump Skids ▪ Repairs & Services

12305 Kurland Dr, Houston, TX 77034  
RotatingEquipment@puffer.com 281-240-2000

