

RPH – Single-suction, Single-stage Heavy-duty OH2 Process Pump

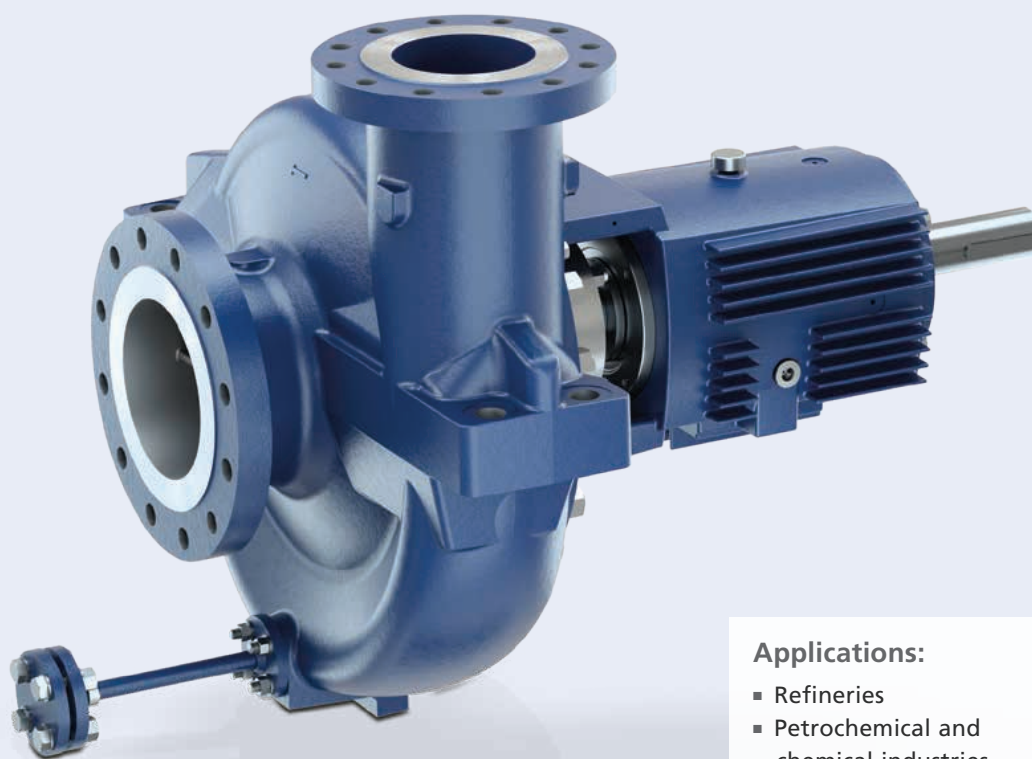

Applications:

- Refineries
- Petrochemical and chemical industries
- Onshore and offshore processes

More information: www.ksb.com

RPH – Single-suction, Single-stage Heavy-duty OH2 Process Pump to API 610 / ISO 13709

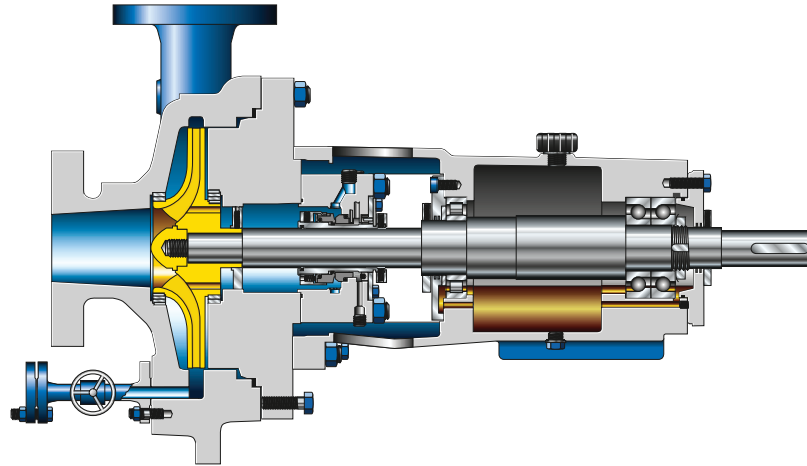

Low maintenance costs

- The selection of a balancing system for the specific duty point markedly reduces axial forces and extends the bearing life.
- The double volute (DN 80 and above) reduces the radial force and prevents shaft deflection. The load on bearings and mechanical seal is thus considerably reduced.

Long service life of the mechanical seal

Maximum permissible shaft diameter to API 610 minimises shaft deflection and vibrations.

Reduced operating costs

A choice of more than 70 hydraulic systems enables optimum pump selection to API for higher efficiencies.

High flexibility

The pump flanges are available for all common pipelines, meeting all standards up to PN100 / ASME Class 600.

Long service life and high reliability of bearings

- Heavy-duty 40° angular contact thrust bearings exceeding API requirements
- Oil bath or oil mist lubrication

No cooling water circuit required

When fluid temperature and ambient temperature are high, the steel bearing bracket with integrated cooling fins and the optional fan impeller protect the unit from overheating.

Ease of maintenance

Mechanical seals to ISO 24109 / API 682 in cartridge design are easy to install/remove for maintenance

| Materials | Technical data | 50 Hz | 60 Hz |
|--|------------------|--------------------------------------|--------------------------|
| S5, S6, S8, C6, A8, D1, D2 and special materials | Max. flow rate | 4150 m³/h / 18200 US gpm | 5000 m³/h / 22000 US gpm |
| | Max. head | 270 m / 886 ft | |
| | Max. temperature | -70 °C to +450 °C / -94 °F to 842 °F | |
| | Max. pressure | 110 bar / 1595 psi | |
| | Nominal diameter | 25 – 400 mm / 1-16 in | |

Other values on request



PUFFER Rotating Equipment
Pumps & Parts ▪ Pump Skids ▪ Repairs & Services

12305 Kurland Dr, Houston, TX 77034
RotatingEquipment@puffer.com 281-240-2000



Authorized Sales Partner